

Agilent J-BERT N4903 High-Performance Serial BERT

User Guide



Agilent Technologies

Notices

© Agilent Technologies, Inc. 2008

No part of this manual may be reproduced in any form or by any means (including electronic storage and retrieval or translation into a foreign language) without prior agreement and written consent from Agilent Technologies, Inc. as governed by United States and international copyright laws.

Manual Part Number

N4903-91020

Edition

Release edition, June 2008

Printed in Germany

Agilent Technologies, Deutschland GmbH
Herrenberger Str. 130
71034 B blingen, Germany

Warranty

The material contained in this document is provided "as is," and is subject to being changed, without notice, in future editions. Further, to the maximum extent permitted by applicable law, Agilent disclaims all warranties, either express or implied, with regard to this manual and any information contained herein, including but not limited to the implied warranties of merchantability and fitness for a particular purpose. Agilent shall not be liable for errors or for incidental or consequential damages in connection with the furnishing, use, or performance of this document or of any information contained herein. Should Agilent and the user have a separate written agreement with warranty terms covering the material in this document that conflict with these terms, the warranty terms in the separate agreement shall control.

Technology Licenses

The hardware and/or software described in this document are furnished under a license and may be used or copied only in accordance with the terms of such license.

Restricted Rights Legend

If software is for use in the performance of a U.S. Government prime contract or subcontract, Software is delivered and licensed as "Commercial computer software" as defined in DFAR 252.227-7014 (June 1995), or as a "commercial item" as defined in FAR 2.101(a) or as "Restricted computer software" as defined in FAR 52.227-19 (June 1987) or any equivalent

agency regulation or contract clause. Use, duplication or disclosure of Software is subject to Agilent Technologies' standard commercial license terms, and non-DOD Departments and Agencies of the U.S. Government will receive no greater than Limited Rights as defined in FAF 52.227-14 (June 1987) or DFAR 252.227-7015(b)(2) (November 1995), as applicable in any technical data.

Safety Notices

CAUTION

A **CAUTION** notice denotes a hazard. It calls attention to an operating procedure, practice, or the like that, if not correctly performed or adhered to, could result in damage to the product or loss of important data. Do not proceed beyond a **CAUTION** notice until the indicated conditions are fully understood and met.

WARNING

A **WARNING** notice denotes a hazard. It calls attention to an operating procedure, practice, or the like that, if not correctly performed or adhered to, could result in personal injury or death. Do not proceed beyond a **WARNING** notice until the indicated conditions are fully understood and met.

Contents

1 Planning the Test

Planning the Test - Concepts	9
Introduction to the Serial BERT	9
Introduction to the Serial BERT - Concepts	9
Which Test is Appropriate?	13
Which Test is Appropriate? - Concepts	13
Connecting the DUT	17
Connecting the DUT - Concepts	17

2 Setting up Patterns

Setting up Patterns - Concepts	23
User Patterns	27
User Patterns - Concepts	27
User Patterns - Procedures	38
User Patterns - Reference	43
Software-Generated PRBS	51
Software-Generated PRBS - Concepts	51
Software-Generated PRBS - Procedures	53
Software-Generated PRBS - Reference	53
Hardware-Generated PRBS	53
Hardware-Generated PRBS - Concepts	53
Hardware-Generated PRBS - Procedures	55
Hardware-Generated PRBS - Reference	56
User-Defined Sequences	56
User-Defined Sequences - Concepts	56
User-Defined Sequences - Procedures	59
User-Defined Sequences - Reference	61

3 Setting up the Pattern Generator

Setting up the Pattern Generator - Concepts	69
---	----

Input and Output Ports	70
Input and Output Ports - Concepts	70
Input and Output Ports - Procedures	79
Input and Output Ports - Reference	82
Bit Rate	87
Bit Rate - Concepts	87
Bit Rate - Procedures	90
Bit Rate - Reference	91
Trigger Output	93
Trigger Output - Concepts	93
Trigger Output - Procedures	94
Trigger Output - Reference	94
Delay Control Input	97
Delay Control Input - Concepts	97
Delay Control Input - Procedures	98
Delay Control Input - Reference	99
Error Addition/Insertion	99
Error Addition/Insertion - Concepts	99
Error Addition/Insertion - Procedures	99
Error Addition/Insertion - Reference	101
Pattern Alternation	102
Pattern Alternation - Concepts	102
Pattern Alternation - Procedures	104
Pattern Alternation - Reference	106

4 Setting up the Error Detector

Setting up the Error Detector - Concepts	109
Inputs and Outputs	110
Inputs and Outputs - Concepts	110
Inputs and Outputs - Procedures	114
Data Input Setup - Reference	114
Clock Setup	116
Clock Setup - Concepts	116
Clock Setup - Procedures	121
Clock Setup - Reference	122
Sampling Point Setup	126
Sampling Point Setup - Concepts	126
Sampling Point Setup - Procedures	129
Sampling Point Setup - Reference	131

Trigger and Aux Output	136
Trigger and Aux Output - Concepts	136
Trigger and Aux Output - Procedures	137
Trigger and Aux Output - Reference	137
Pattern Synchronization	138
Pattern Synchronization - Concepts	138
Pattern Synchronization - Procedures	150
Pattern Synchronization - Reference	151
Error Accumulation	151
Error Accumulation - Concepts	151
Error Accumulation - Procedures	152
Error Accumulation - Reference	152
BER Location	154
BER Location - Concepts	154
BER Location - Procedures	155
BER Location - Reference	155
Audio Signals	156
Audio Signals - Concepts	156
Audio Signals - Procedures	156
Audio Signals - Reference	157

5 Advanced Analysis

Advanced Analysis - Concepts	159
Advanced Analysis - Procedures	161
Advanced Analysis - Reference	166
DUT Output Timing/Jitter	173
DUT Output Timing/Jitter - Concepts	173
DUT Output Timing/Jitter - Procedures	182
DUT Output Timing/Jitter - Reference	184
Output Levels	195
Output Levels - Concepts	195
Output Levels - Procedures	198
Output Levels - Reference	203
Eye Opening	220
Eye Opening - Concepts	220
Eye Opening - Procedures	223
Eye Opening - Reference	229

Error Location Capture	236
Error Location Capture - Concepts	236
Error Location Capture - Procedures	238
Error Location Capture - Reference	239
Fast Eye Mask	241
Fast Eye Mask - Concepts	241
Fast Eye Mask - Procedures	244
Fast Eye Mask - Reference	246
Eye Diagram	249
Eye Diagram - Concepts	249
Eye Diagram - Procedures	254
Eye Diagram - Reference	267
Spectral Jitter	278
Spectral Jitter - Concepts	278
Spectral Jitter - Procedures	286
Spectral Jitter - Reference	289

6 Evaluating Results

Evaluating Results - Concepts	297
Instantaneous Measurements	297
Instantaneous Measurements - Concepts	297
Instantaneous Measurements - Procedures	298
Instantaneous Measurements - Reference	300
Accumulated Measurements	302
Accumulated Measurements - Concepts	302
Accumulated Measurements - Procedures	303
Accumulated Measurements - Reference	304
Eye Measurements	310
Eye Measurements - Concepts	310
Eye Measurements - Procedures	311
Eye Measurements - Reference	311

7 Jitter Tolerance Tests

Jitter Tolerance Tests - Concepts	315
Jitter Setup	325
Jitter Setup - Concepts	325
Jitter Setup - Procedures	326
Jitter Setup - Reference	328

Interference Channel Setup	336
Interference Channel Setup - Concepts	336
Interference Channel Setup - Procedures	336
Interference Channel Setup - Reference	337
Jitter Tolerance Characterization	338
Jitter Tolerance Characterization - Concepts	338
Jitter Tolerance Characterization - Procedures	343
Jitter Tolerance Characterization - Reference	348
Jitter Tolerance Compliance	352
Jitter Tolerance Compliance - Concepts	352
Jitter Tolerance Compliance - Procedures	359
Jitter Tolerance Compliance - Reference	368

8 Solving Problems

Solving Problems - Concepts	375
Setup Problems	375
Setup Problems - Concepts	375
Measurement Problems	378
Measurement Problems - Concepts	378
Other Messages	384
Other Messages - Concepts	384
Problems with the N4916A	386
Problems with the N4916A - Concepts	386

9 Customizing the Instrument

Customizing the Instrument - Concepts	395
Restoring the System	395
Restoring the System - Procedures	395
Configuring the Instrument	397
Configuring the Instrument - Concepts	397
Configuring the Instrument - Procedures	398
Configuring the Instrument - Reference	400
Configuring the Touchscreen	400
Configuring the Touchscreen - Procedures	400
Configuring the Touchscreen - Reference	403
Installing Software Licenses	404
Installing Software Licenses - Procedures	404
Installing Software Licenses - Reference	405

Installing Hardware Options	406
Installing Hardware Options - Procedures	406
Installing the N4916A	407
Installing the N4916A - Procedure	407
Installing Webserver	414
Customizing the Web Server- Concept	414
Printing	418
Printing - Procedures	418
File Management	421
File Management - Procedures	421
Preset Instrument State	425
Preset Instrument State - Procedures	425
Self Test	426
Self Test - Concepts	426
Self Test - Procedures	426
Self Test - Reference	427

Index	429
-------	-----

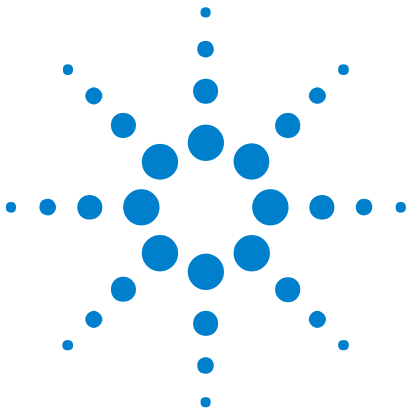

1 Planning the Test

Planning the Test - Concepts

The following topics provide some information that can help you in planning tests with the Serial BERT:

- “[Introduction to the Serial BERT - Concepts](#)” on page 9 explains the basics of bit error rates (BER) and BER testing with the Serial BERT.
- “[Which Test is Appropriate? - Concepts](#)” on page 13 provides you with some basic information about the types of testing you can do with the Serial BERT.
- “[Connecting the DUT - Concepts](#)” on page 17 tells you how you should connect your DUT to the Serial BERT.

Introduction to the Serial BERT

Introduction to the Serial BERT - Concepts

These topics explain some of the basics of BER, Serial BERT, and BER testing with the Serial BERT.

Important Information about the Pattern Generator Outputs

The pattern generator output ports must be terminated with 50 Ω if they are not connected:

- Data Out
- $\overline{\text{Data Out}}$



- Clock Out
- Clock Out

Termination of output ports improves the test performance.

Important Information Regarding Security

The Serial BERT is a PC-based instrument with a standard Windows operating system. As such, it is subject to the same security protection measures as any other PC.

See the Microsoft web site for more information regarding data security:

<http://www.microsoft.com/security/default.msp>

Every user must have administrator privileges to run the Serial BERT firmware. Otherwise the firmware does not have access to the instrument's hardware.

It is recommended that you create a recovery disk for the instrument. See [“How to Restore the Operating System” on page 396](#).

Note also that there is a recovery image on the hard disk. See the Windows Help for instructions on restoring a recovery image.

Understanding BER

Bit error ratio (BER) is the most fundamental measure of system performance. It is the ratio of the number of errored bits to the total number of bits received.

For example, 1 error in 1000 bits corresponds to a BER of 1/1000 or 1×10^{-3} . This would be displayed on the instrument as 1E-3. Refer to the following table to familiarize yourself with how BERs are displayed. Notice that smaller exponents correspond to higher BERs, and larger exponents correspond to lower BERs.

Table 1

Fraction	Exponent	Instrument Display
1/1	1×10^0	1E+0
1/10	1×10^{-1}	1E-1
1/100	1×10^{-2}	1E-2
1/1000	1×10^{-3}	1E-3

Table 1

Fraction	Exponent	Instrument Display
1/10,000	1×10^{-4}	1E-4
1/100,000	1×10^{-5}	1E-5
1/1,000,000	1×10^{-6}	1E-6
1/10,000,000	1×10^{-7}	1E-7

Understanding the Serial BERT

The Serial BERT, also referred to as a Bit Error Ratio Tester (BERT), is a powerful instrument that enables you to analyze systems and components in the telecommunication and enterprise communication industries. It is an essential tool for designing and troubleshooting communications systems, high-speed integrated circuits (ICs), and photonic components. Its intuitive operation and leading edge performance will help you quickly verify error performance.

The Serial BERT comes with advanced jitter generation capabilities for jitter tolerance testing (J-BERT). The instrument provides:

- Excellent waveform performance
- Outstanding rise times and jitter performance
- A choice of logic family interfaces
- Easy object-oriented programming with the IVI-COM interface
- Remote commands similar to HP/Agilent 71603B
- A variety of ways in which to accumulate and view test results
- A collection of example patterns
- Convenient online documentation
- Automatic setup of optimum sampling point
- A variety of powerful advanced analysis tools
- Special support for jitter analysis and characterization

Which Features are Available?

The Serial BERT is available with different options. They differ in the range of provided bit rates and in the available features.

1 Planning the Test

Depending on the options you bought you can have the following installed:

- C07
Bit rate range: 150 Mbit/s to 7 Gbit/s with built-in clock data recovery (CDR)
- C13
Bit rate range: 150 Mbit/s to 12.5 Gbit/s with built-in CDR
- U13
Upgrade of a 7 Gbit/s instrument to 12.5 Gbit/s
- CTR, UTR
Option/Upgrade for adjustable CDR. The adjustable CDR has an adjustable bandwidth, a selectable peaking, and an SSC tracking.
- A01
Bit Recovery Mode (measures BER without expecting a particular pattern)
- J10, U10
Option/Upgrade for jitter injection. Total jitter can be composed from random, periodic, sinusoidal, and bounded uncorrelated sources.
- J11
Spread Spectrum Clock (SSC) generation.
- J12
Option/Upgrade for Jitter Tolerance Compliance tests. Use this test to ensure that the jitter tolerance of the device under test complies with a certain standard.
- J20
User-installable hardware module "Interference Channel" for simulating intersymbol and sinusoidal interference

To check the options of your Serial BERT, press **About** in the **Help** menu. The **About** dialog shows the installed options.

N4916A De-Emphasis Signal Converter

An external optional instrument is the N4916A De-Emphasis Signal Converter. It is used to convert the output of the pattern generator to a de-emphasized signal, as required by many standards such as PCI

Express, SATA 3 Gb/s, fully buffered DIMM, Hypertransport, CEI, or 10 GbE.



Once the N4916A is connected, it can be conveniently controlled via the Serial BERT.

Which Test is Appropriate?

Which Test is Appropriate? - Concepts

These topics help you to decide on the appropriate test setup for your device.

Determining How to Test Your Device

The Serial BERT can help you test the performance of components and systems for high-speed digital transmission equipment.

An important parameter of a digital system is the rate at which errors occur in the system. The analyzer will compare the bits sent to your device with the bits received from your device. It will record the number of bit errors and display results such as the bit error ratio (BER). In addition, accumulated results can be analyzed to help you determine what caused the bit errors.

The analyzer can be set up to work with your device in many different ways. To determine the best measurement setup, you must first decide how you want to test your device. Before actually setting up and making measurements, you may want to consider the following questions:

- What is the purpose of your test?
- What are the testing requirements of your device?

What is the Purpose of Your Test?

Does the purpose of your test fall under one of the following categories?

- To monitor instantaneous BER during measurement setup, experiments, and adjustments. See [“Instantaneous Measurements - Concepts ” on page 297.](#)
- To measure and log error performance over time. See [“Accumulated Measurements - Concepts ” on page 302.](#)
- To measure the eye height and width of the incoming data signal at specific alignment BER thresholds. See [“Eye Measurements - Concepts ” on page 310.](#)

The following references may also be helpful in determining how to test your device.

- For a list of recommended patterns for your device and application, see [“When to Use Which Pattern?” on page 26.](#)
- For a list of recommended connection diagrams for your device and application, see [“Connecting the DUT - Concepts ” on page 17.](#)

What are the Testing Requirements of Your Device?

Considering the requirements of your device will help you choose which instrument functions to use during the test setup and when making measurements.

- Do you need to use a custom test pattern?

If you have a long series of 1's or 0's in your custom pattern, be sure to avoid false sync. See [“What is False Synchronization?” on page 142](#)

- Do you want to use alternating patterns?

Then you must first import or create a custom pattern that contains an A half (pattern A) and B half (pattern B). See [“Pattern Alternation - Concepts ” on page 102.](#)

- Are you aware of how custom pattern size can affect the pattern output?

See [“Why the Serial BERT Repeats Memory-Based Patterns” on page 31.](#)

- Do you need more than two patterns or a mix of custom patterns and PRBS?
- Does your device change the input pattern it receives?

If your device inverts logic, then select **Data Inverted** in the **Sampling Point Setup** window. If your device changes patterns in other ways,

then you must know the expected output pattern and select it as the error detector reference pattern.

- What logic family is your device compatible with?

The pattern generator has preset voltage levels to work with ECL, SCFL, LVPECL, LVDS, and CML. Be sure to select the correct logic family. See [“Understanding how the Serial BERT Uses Logic Families and Terminations”](#) on page 74.

- What is the input termination voltage of your device?

Make sure it is the same voltage as displayed in the pattern generator termination list.

- What termination voltage is the output of your device designed to work with?

Make sure it is set for the error detector's data port termination. See [“Data In Port Termination”](#) on page 113.

- What bit rate do you need to test your device at?

The Serial BERT allows you to run tests from 150 Mb/s up to 12.5Gb/s (depending on the options with which you bought the instrument). See [“Error Detector Bit Rate”](#) on page 122 for more information.

- Does your device require differential inputs?

As complementary outputs, Data/Clock Out and $\overline{\text{Data/Clock Out}}$ may satisfy this requirement. See [“Diagram 2. Connections for Differential Inputs”](#) on page 18.

- Is the output of your device noisy or very small in amplitude?

You may need to manually set up a sampling point. See [“Sampling Point Setup - Concepts ”](#) on page 126.

- Do you want to check the BER in bursts (for example, for loop testing applications)?

The Serial BERT provides capabilities that help you set up and run burst tests. See [“Introduction to Burst Sync Mode”](#) on page 144.

- Are you aware of how the sync mode setting can affect the way errors are measured and displayed?

See [“What Type of Synchronization Should You Use?”](#) on page 141.

Test Times and Confidence Levels

A true BER measurement must be statistically valid. Because it is not possible to predict with certainty when errors will occur, your device must be tested long enough to have confidence in its BER performance. The table below lists the test times required for different BERs at specific bit rates.

NOTE

The test times in this table are valid for continuous measurements. If measurements are made in bursts, the test times will be longer (continuous test time divided by the burst duty cycle times the burst sync ratio). See ["Introduction to Burst Sync Mode" on page 144](#) for background information.

The test times for 95% confidence level are:

Table 2

BER	STM-64/ OC-192 (9.95328 Gb/s)	STM-16c/ OC-48c (2.48832 Gb/s)	STM-4c/ OC-12c (622.08 Mb/s)	STM-1/OC-3 (155.52 Mb/s)
1E-14	~ 8.4 hours	~ 1.4 days	~ 5.6 days	~ 22.4 days
1E-13	~ 50 minutes	~ 3.3 hours	~ 13 hours	~ 2.2 days
1E-12	~ 5 minutes	~ 20 minutes	~ 80 minutes	~ 5.3 hours
1E-11	~ 30 seconds	~ 2 minutes	~ 8 minutes	~ 32 minutes
1E-10	~ 3 seconds	~ 12 seconds	~ 48 seconds	~ 3.2 minutes

The formula for confidence level is as follows:

$$C = 1 - e^{-nb}$$

Where:

C = degree of confidence (0.95 = 95%)

e = natural base number

n = number of bits examined without error

b = desired residual BER

You may want to prove that your device has a certain residual BER. If you know this desired BER and the desired confidence level, you can calculate the number of bits that must be measured without error. The number of bits, in turn, can be translated into a period of time at a certain bit rate. That is what is done in the above table.

The following example shows how to calculate the number of bits if the desired BER (b) is 1E-10 and the desired confidence level (C) is 95%:

- 1 Change formula "C = 1 - e^{-nb}" to solve for the number of bits (n)

$$n = -\ln(1-C)/b$$

- 2 Replace variables C and b

$$n = -\ln(1 - 0.95)/1E-10$$

- 3 Calculate the number of bits

$$n = -\ln(1 - 0.95)/1E-10 = 2.99/1E-10 = 2.99E+10 \text{ bits}$$

- 4 Calculate the time period at the STM-16/OC-48 bit rate (2.48832 Gb/s)

$$2.99E+10 / 2.48832E+9 = 12.016 \text{ seconds}$$

Connecting the DUT

Connecting the DUT - Concepts

This section provides information on how to connect your DUT for several common test scenarios.

NOTE

The pattern generator's Data Out and Clock Out ports must be terminated with 50 Ω if they are not connected.

The following procedure is recommended when setting up a test:

- 1 If your DUT can handle 0V, press the **0V (Disable)** button in the **PG Output Setup** screen.

The pattern generator's Data Out and Clock Out outputs are set to 0V. This is indicated in the **PG Output Setup** screen.

- 2 Connect the DUT as necessary.
- 3 Terminate any non-connected Data Out and Clock Out ports (normal and complementary).
- 4 If the outputs are disabled, press the **0V (Disable)** button to enable them.

To avoid damaging your device, set up the devices properly before making connections.

CAUTION

ESD can damage or destroy electronic components. Coaxial cables with both ends unconnected may store electrostatic charges. Before connecting any coaxial cable of this sort to a device or instrument, momentarily short the center and outer conductors of the cable. When making connections, ensure the proper use of a grounded, resistor-isolated wrist strap.

Connect your device according to the diagrams below:

Diagram 1. Connections for Different In/Out Data Rates

Often used for multiplexers, or when the data rate received by the device is not equal to the data rate sent from the device.

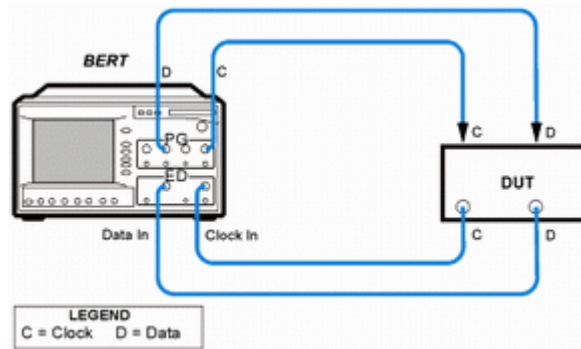

Diagram 2. Connections for Differential Inputs

Application is the same as in Diagram 1. Illustrates how to connect to a device requiring differential signals.

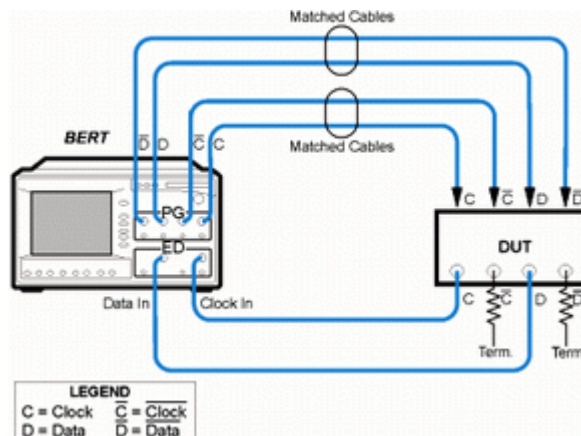

Diagram 3. Connections for an Amplifier

Often used for amplifiers.

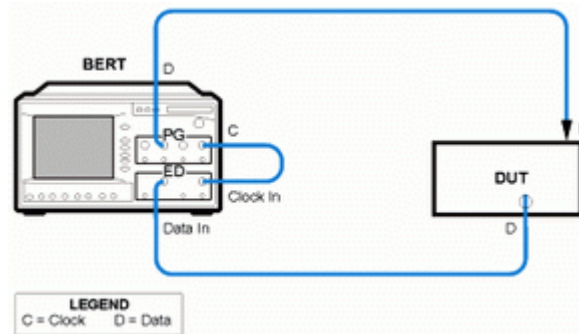

Diagram 4. Connections for a Flip-Flop

Often used for flip-flops.

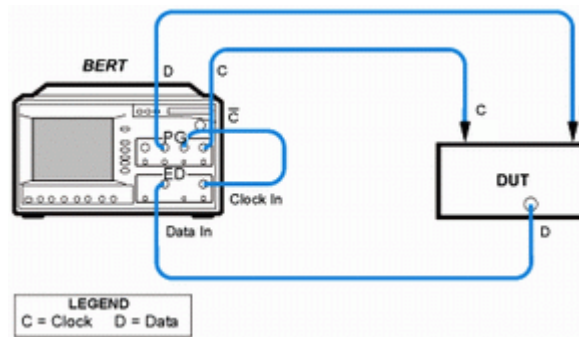

Diagram 5. Connections for a MUX/DEMUX Pair

Used to test multiplexer/demultiplexer (MUX/DEMUX) pairs. For accurate measurement results, the timing of data signals between the MUX/DEMUX pair must be set properly.

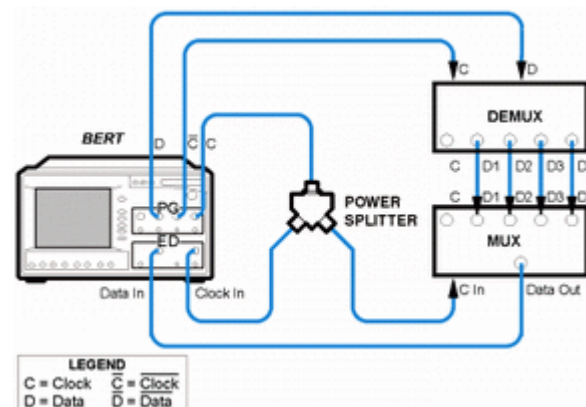

Diagram 6. Connections for a DCA or Oscilloscope (PGOnly)

Used for measuring the output waveform of your device. For the least amount of jitter, the clock output signal may be used as a trigger for the oscilloscope.

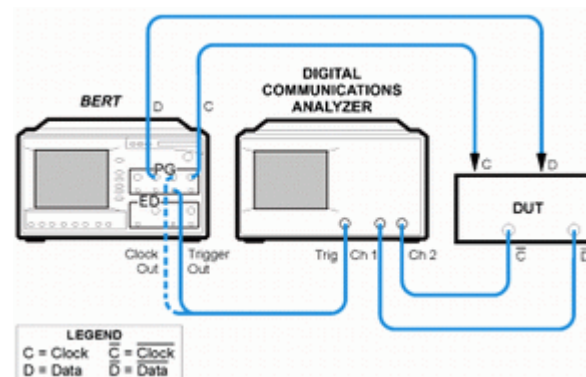

Diagram 7. Connections for a SONET/SDH Receiver (PGOnly)

Often used with network equipment, such as SONET/SDH receivers. The device shown may or may not require a clock signal.

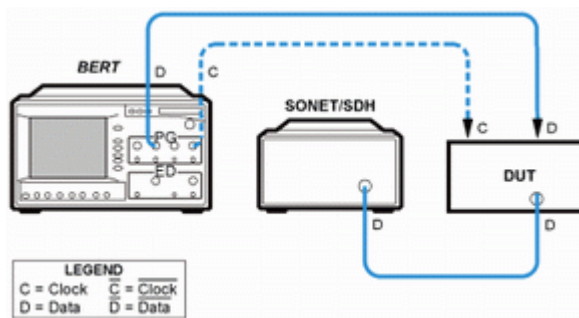
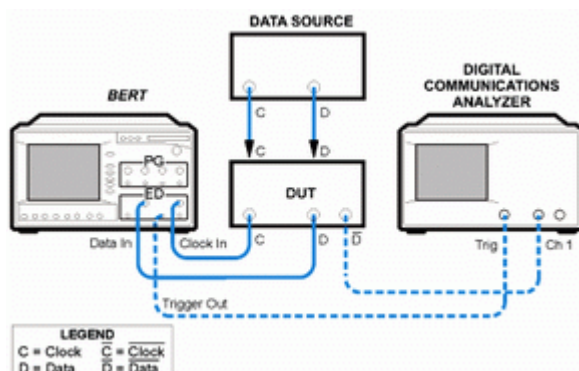

Diagram 8. Connections for an External Data Source (EDOnly)

Used when the device is stimulated by another data source. Illustrates the use of an oscilloscope in addition to the error detector.



NOTE

As in all setups, the pattern sent to the error detector must be the same as the internal reference pattern of the error detector. Dynamic patterns and/or patterns with live payloads cannot be used.

NOTE

Diagrams 1 through 8 can use an external clock reference connected to the Clock In port of the pattern generator, if desired.

Diagram 9. Connections of the De-Emphasis Signal Converter

The Data Output of the Pattern Generator is connected to the Input of the N4916A. The unused output of the Pattern Generator has to be terminated with 50 Ohm.

The N4916A provides a differential signal to the DUT.

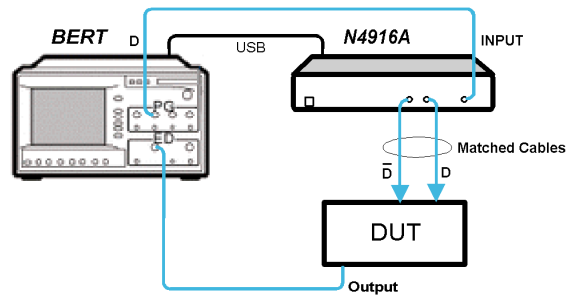

The N4916A is controlled by the Serial BERT via a USB cable connected to ports at the rear of the instruments.

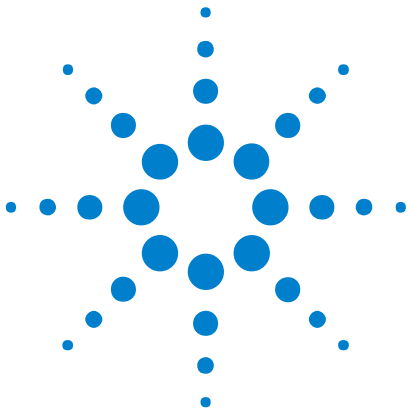

2 Setting up Patterns

Setting up Patterns - Concepts

The purpose of data patterns is to simulate the type of data that your device might receive in the real world. Different patterns present different data loads to your device, which can cause variations in the bit error ratio. A bit pattern is sent from the pattern generator to your device. At the same time, the expected output pattern of your device is internally generated in the error detector (to provide a reference).

Selecting a pattern is the first step in setting up a BER measurement. The Serial BERT provides various patterns to fulfill most standard testing needs.

How does the Serial BERT Generate Patterns?

The Serial BERT has two possibilities for generating patterns: either by directly generating them from the hardware, or by loading patterns into the memory and generating the output according to the pattern in the memory. These memory-based patterns can be either user patterns (file-based), or software-generated patterns.

Hardware-Generated Patterns

The hardware-generated patterns available with the Serial BERT are PRBS $2^n - 1$ patterns. They provide long, high-speed, random traffic patterns that can be used for testing a wide range of devices. These patterns cannot be manipulated in any way.

Memory-Based Patterns

The memory-based approach is more flexible. It makes it possible to define any pattern (within the physical limits of the memory) for defining the output. The Serial BERT provides two possibilities for defining the output: by defining user patterns or by selecting a software-generated pattern.

User Patterns

User patterns are file-based, editable patterns. These may be patterns that you set up using the Serial BERT's **Pattern Editor**, or any of the



2 Setting up Patterns

patterns delivered with the Serial BERT. You can easily define your own patterns for any special requirements.

Software-Generated Patterns The Serial BERT can also generate various PRBS 2^n patterns with a range of polynomials from 7 to 23. These patterns can be further modified by setting special mark densities (ratio of 1's to total bits) or by defining the zero substitution.

Sequences It is possible to combine several patterns in a sequence. A sequence consists of up to four blocks that can be looped. Each block can generate a pause signal (constant 0 or 1), a divided clock, a $2^n - 1$ PRBS, or a user pattern.

What Patterns are Available?

The Serial BERT offers various industry standard and customized patterns for many BER testing scenarios.

The following graphic illustrates what patterns are available on the Serial BERT. Note that there are two main branches, corresponding to the hardware-generated and memory-based patterns, and the memory-based patterns are further broken down into software-generated patterns and user patterns.

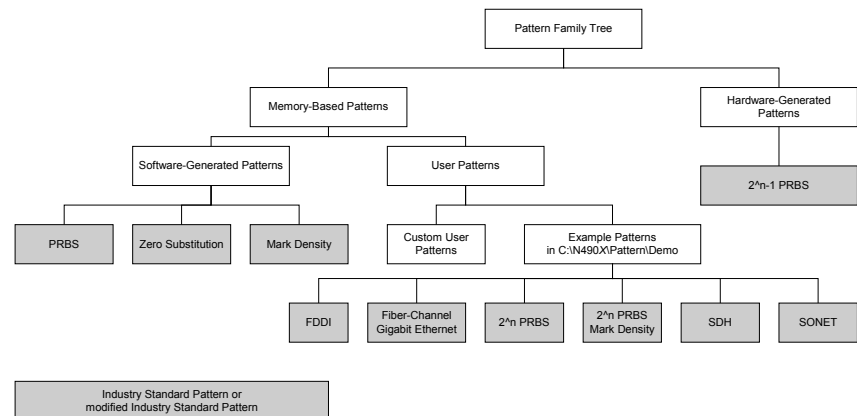

See “[Example Patterns](#)” on page 33 for a complete listing of the example patterns.

What is PRBS?

The most common type of industry-standard pattern is the Pseudo-Random Binary Sequence (PRBS). PRBSs have a number of desirable properties, including the ability to simulate random data with a balanced number of 1's and 0's.

They are referred to by their pattern lengths, which are powers of 2. Longer pattern lengths give a better approximation of random data and provide a more rigorous test for the device. However, the pattern repetition time is significantly longer.

PRBS patterns provide a means to simulate the type of traffic that a system is likely to see: random traffic. They also enable you to stress your system to its limits, because large patterns that include long strings of 1's or 0's are more stressful.

The patterns are easy to generate and can measure at high speeds, because they are sent repeatedly and can be predicted. Pattern synchronization, for example, is very fast. When you compare the sequence with itself, you get 50% errors in all positions, except when the pattern is exactly aligned.

Hardware-generated PRBSs are non-inverted PRBS $2^n - 1$ patterns that allow high-speed measurement of random traffic. They enable stressful testing of devices, because large patterns contain long strings of 0's and 1's.

Software-generated PRBSs are non-inverted PRBS 2^n patterns. They are also called PRBN patterns. These patterns are useful for applications where the pattern length must be an even number. The Serial BERT provides variations of software-generated PRBS patterns, allowing you to set a pattern's mark density (ratio of 1's) and zero substitution. These features make it easier for you to run specific stress tests on your DUT.

The following figure illustrates the PRBS-based patterns available with the Serial BERT:

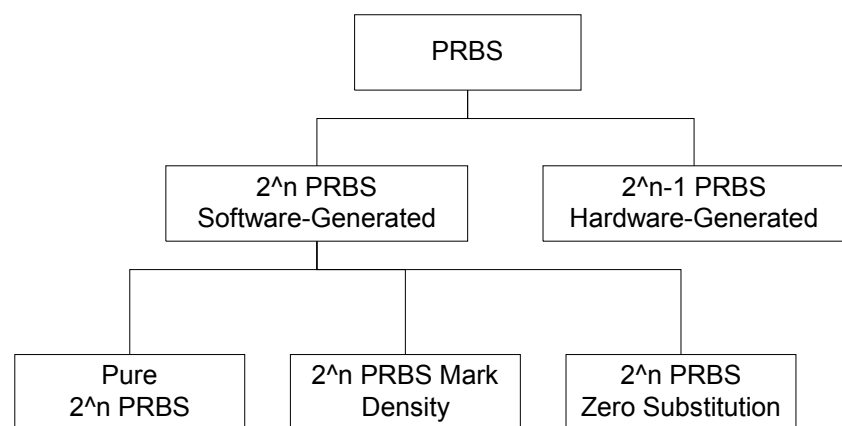

PRBS Frequency Spectrum Digital non-return to zero (NRZ) data has a $(\sin x/x)^2$ characteristic frequency spectrum. The PRBS frequency spectrum follows this envelope, with line spectra of spacing related to the sequence repetition rate. The longer the sequence before it repeats, the narrower the line spacing (closer to a continuous spectrum).

Line spacing = bit rate/sequence length

The closer to a continuous spectrum, the more the test signal looks like an analog noise source. The benefit of this is that such a stimulus shows any frequency-dependent effects in a device under test. For example, a clock recovery circuit designed to lock onto a single frequency may have a tendency to lock onto harmonics. A long PRBS may uncover such undesirable behavior.

When to Use Which Pattern?

Selecting the appropriate pattern and test setup for your application is important. Below is a list of recommendations that may be helpful.

- To simulate random traffic, choose PRBS.
- For functional and alarm testing, choose alternating memory patterns.
- If the test pattern requires a header, choose one of the [“Example Patterns” on page 33](#) or use a custom pattern.
- To stress lightwave transmitters and receivers, vary the mark density of the pattern with a modulator or e/o converter.
- To induce baseline wander for margin testing, vary the mark density and use alternating patterns.
- For pattern dependency testing, choose one of the [“Example Patterns” on page 33](#) or use a custom user pattern; vary the mark density.
- For eye diagram measurements and mask analysis, use the Serial BERT with a digital communication analyzer or oscilloscope.
- For receiver sensitivity or eye contour measurements, use the Serial BERT with a digital communication analyzer or oscilloscope.
- For a clock recovery circuit stress test, vary the mark density or use CID (Consecutive Identical Digit) patterns that contain long runs of 1's and 0's.

Alternatively, use the Serial BERT or a DCA with an ITU-T specified pattern for testing STM-n systems. This pattern is to verify the adequacy of timing recovery and low frequency performance of STM-n systems. It consists of a user pattern that is comprised as follows:

The first row of overhead bytes for the STM-n system, all ones (zero timing content, high average signal amplitude), pseudo-random data with 50 % mark-density ratio. This is followed by a repeat of the pattern overhead, all zeros (zero timing content, low average signal amplitude), and the PRBS. For full details, see *ITU-T Recommendation G.958*.

- For a regenerator test, set up the bit rate according to the device specification.

TIP

If your device converts the input pattern, the error detector needs a different pattern than the pattern generator. See [“Loading Patterns to the Pattern Generator and Error Detector” on page 41](#) for details.

User Patterns

User Patterns - Concepts

User patterns are user-editable patterns that are written to the Serial BERT's memory for pattern generation (see [“How does the Serial BERT Generate Patterns?” on page 23](#) for details). User patterns can contain up to 32Mbit of any arbitrary data pattern. They may be generated by the Serial BERT software or defined in a pattern file and loaded into the memory. The Serial BERT reads the memory bit by bit, and generates the output accordingly.

The following topics explain how the Serial BERT works with user patterns, and also explain how user patterns are generated.

NOTE

The way software-generated patterns (distorted PRBS, PRBN) are output is identical to that of user patterns: The patterns are written to the memory, and the output is generated from there. Some of the information in these topics covers how the patterns are actually generated, and thus also applies to software-generated patterns.

When to Test with User Patterns

Creating or editing patterns is necessary for quality testing because different patterns present different data loads to the device. This can cause variations in the bit error ratio. With user patterns, you can define exactly the pattern used in the test.

Supported Pattern Types

The Serial BERT can import the following pattern types:

- HP/Agilent 71600 series patterns (*.dat file type).
- Patterns saved as ASCII files by the Serial BERT or the Agilent 86130 (*.ptrn and *.txt file type).

These are described in detail in [“Pattern File Specifications” on page 28](#).

The Serial BERT can save files as either *.dat, *.ptrn or *.txt files.

NOTE

Downloading a text format pattern into your instrument may take significantly longer than a binary pattern.

NOTE

If you save a modified text format pattern to the same file name, it is always saved in binary format. If you wish to preserve the original text format file, use the **Save As** file command and save the data to a different file.

Pattern File Specifications

For your instrument to download a pattern file, the pattern must be composed of at least 7 lines. The first 6 lines start with a keyword to identify the field, followed by an '=' sign. There should be no spaces around the '=' sign and no blank lines.

Use the following keywords and examples to construct your ASCII file. Note that the keywords must appear in the given order.

- | | |
|--------------------|---|
| Version | The version field is used to identify different file versions. For this software version, the field should be set to EPA 2.0. An exact match for this field is required for the pattern to load correctly.

Syntax: Version=EPA 2.0 |
| Format | The format field identifies whether the pattern is in dual, hexadecimal, or binary format.

Syntax: Format=<Dual Hex Text Bin>

Hex and text formats are identical. |
| Description | This is the creator's description of the pattern. The data after the '=' sign is read until the end of the line and used directly as the pattern description. The maximum number of characters is 256. |

Count This identifies standard and alternating patterns. Standard patterns have a value of 1; alternating patterns have a value of 2. Any other value is not valid.

Syntax: Count=<1 | 2>

Length This is the length of the pattern in bits. For a standard pattern of 128 bits, for example, the value is 128. For an alternating pattern, it is the length of one of the patterns only.

Data The "Data" tag identifies the start of the pattern data itself. For standard patterns, there is only one "Data" tag. Alternating patterns require two "Data" tags. Note that the actual data starts on the *line after* the tag.

Syntax: Data=<CR/LF><data contents>

- In dual format, each character represents one bit-only the numbers '1' and '0' are allowed.
- In hex or text format, each character represents four bits-only the characters '0' to '9' and 'A' to 'F' are allowed (not case-sensitive).
- In binary format, each character represents eight bits-all ASCII characters are allowed.

Example:

'X' in binary format or '88' in hex or text format produce the same bit sequence as 10001000 in dual format.

In hex or text format, the data must be separated by one white space. The white space can be a tab, a space, or a new line.

In hex or text format: For pattern lengths that are not multiples of 8 bits, the data has to be padded to provide the correct number of hex characters. The extra bits are ignored.

ASCII Pattern Files Examples

```
Standard Pattern in Text Version=EPA 2.0
Format=Hex
Description=This is a simple standard pattern
Count=1
Length=128
Data=
01 02 03 04 10 20 40 80
ff 00 ff 00 ff 00 ff 00
```

2 Setting up Patterns

```
Alternating Pattern in Text  Version=EPA 2.0
                             Format=Text
                             Description=This is a simple alternating pattern
                             Count=2
                             Length=96
                             Data=
01 02 03 04 10 20 40 80 ff 00 ff 00
                             Data=
01 02 03 04 10 20 40 80 ff 00 ff 00
```

Pattern Resolutions and Lengths

The Serial BERT has 32Mbits (8 MB) RAM for storing patterns. As discussed in [“How the Serial BERT Generates Memory-Based Patterns” on page 31](#), all patterns are loaded into the RAM until a 512-bit boundary is reached. If the pattern is an odd number of bits long, it is loaded into the RAM 512 times. Because of the restricted memory space, there are also restrictions to the pattern lengths.

For example, a user pattern that is 256,001bit bit long would have to be loaded into the RAM 512 times to reach the 512-bit boundary. Such a pattern would occupy more than 128 Mbits in the RAM.

The Serial BERT handles such patterns by rounding them off to the nearest length that would fit in the memory. For the above example, the length would be rounded off to 256,000 bits. This rounding-off factor is known as the pattern's *resolution*. The following table lists all pattern resolutions.

Table 3

Pattern length (standard)	Pattern length (alternate)	Resolution
≤ 64 kbit	≤ 32 kbit	1 bit
> 64 kbit	> 32 kbit	2 bit
> 128 kbit	> 64 kbit	4 bit
> 256 kbit	> 128 kbit	8 bit
> 512 kbit	> 256 kbit	16 bit
> 1 Mbit	> 512 kbit	32 bit
> 2 Mbit	> 1 Mbit	64 bit

Table 3

Pattern length (standard)	Pattern length (alternate)	Resolution
> 4 Mbit	> 2 Mbit	128 bit
> 8 Mbit	> 4 Mbit	256 bit
> 16 Mbit	> 8 Mbit	512 bit

How the Serial BERT Generates Memory-Based Patterns

The basic concept of how the Serial BERT generates memory-based patterns is relatively simple: The Serial BERT has 32Mbits of internal RAM memory used to store data patterns. The RAM is organized in 64k of 512-bit blocks.

During test run, the pattern generator reads this memory bit by bit and generates the corresponding voltage at the output port (1=high, 0=low). The error detector compares the incoming signal voltage (=data bits) with the bits in the memory and counts the errors.

The Serial BERT has actually three RAM memory locations where patterns are stored: in the Pattern Editor memory, in the pattern generator, and in the error detector. When you modify patterns with the pattern editor, the patterns in the pattern generator and error detector are not automatically updated.

For this, you need to write the pattern to the pattern generator and/or the error detector. There the pattern is saved in the RAM of the respective module.

Why the Serial BERT Repeats Memory-Based Patterns

To generate output signals, the Serial BERT can send only complete 512-bit blocks of data. To maintain predictability of the output signal, it is necessary to send complete patterns. This applies to user patterns, alternating patterns, memory-based PRBN patterns, mark density patterns, and zero substitution patterns.

Therefore, when the Serial BERT loads a pattern into its internal memory, it repeats the pattern as necessary until the pattern reaches a block boundary. For example, if a 1023-bit pattern is loaded, this is repeated in the RAM 512 times, and thus occupies 1023 blocks. Or, if a 192-bit pattern is loaded, this is repeated 8 times, and occupies 3 blocks, as indicated in the following figure. This applies to all memory-based patterns available to the Serial BERT.

2 Setting up Patterns

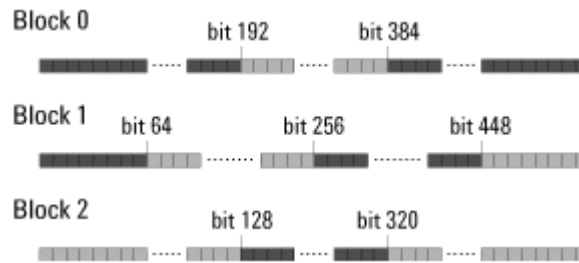

During test run, the Serial BERT always sends out all blocks of a pattern. In the case of the 192-bit pattern mentioned above, the pattern is repeated 8 times when sent out (in effect, making it a 1536-bit pattern).

How the Serial BERT Handles Alternating Patterns

The same behavior of repeating a pattern to fill up complete blocks also applies to alternating patterns. In this case, each half of the pattern is loaded into a separate location in the RAM. When an alternating pattern is generated, first all blocks of pattern A are sent, then all blocks of pattern B are sent, and so on.

A0	A1	A2	B0	B1	B2	A0	A1	A2
A	A	A	B	B	B	A	A	A

Implications of Using Memory-Based Patterns

There are several implications to the way Serial BERT handles memory-based patterns, a few of which are:

- If you set up an alternating pattern where pattern B is a replica of pattern A except for the addition of one error, and the pattern is an odd number of bits long, the error will be repeated 512 times when B is sent (because pattern B is sent 512 times before switching back to A).
- If you want to send a periodic pattern, you only have to define a single repetition. For example, if you want to send alternating 1's and 0's, you only have to define the first two bits. This pattern is automatically loaded 256 times to fill up a complete block of RAM.
- If you set up a trigger to be generated whenever a pattern is sent, the trigger is sent whenever all blocks that store this pattern have been sent (and not every time the pattern is sent).

So, for example, if you have a standard pattern that is 384 bits long, this pattern must be loaded into the memory four times to reach the 512-bit boundary. A trigger would then be generated every 4x384bits, or 1536bits.

Example Patterns

The Serial BERT provides a set of example user patterns. These patterns mimic real data packets and standard stress patterns.

The directory for the example user patterns is: C:\N4903A\Patterns\Demo.

You can access this folder from the Serial BERT's **Start** menu (N4903A **Data** -> **Pattern**).

CAUTION

Any changes you make to the patterns in this folder are non-recoverable (there is no backup folder). To avoid inadvertent changes, it is recommended that you copy the demo files to a different directory before loading them.

This folder contains the following subdirectories with example patterns:

FDDI • FDDI_Jitter.ptn

The Fiber Distributed Data Interface (FDDI) data dependent jitter test pattern is used for testing FDDI components or physical links. The pattern is 1280 bits long and is transmitted continuously during the test by repeating the pattern. The sequence causes a near worst case condition for inter-symbol interference and duty-cycle, baseline wander.

• FDDI_Wander.ptn

The FDDI baseline wander test pattern is used to test FDDI components for the effects of a change in the average DC level of the signal. The first 45,000 bits are of the code group (01010); the last 45,000 bits are of the code group (10101).

Fiber Channel/Gigabit Ethernet • SPAT.ptn

This is a Fiber Channel supply noise stimulus test pattern.

• RPAT.ptn

This is a Fiber Channel random data pattern.

• K28-7.ptn

This pattern is used to test Fiber Channel and Gigabit Ethernet elements. It has a large low frequency content that is used to test low frequency random jitter (RJ) and PLL tracking errors. The pattern is composed of five logic highs, followed by five logic lows. This is repeated continuously and disparity rules are followed.

11111 00000

2 Setting up Patterns

11111 00000 (binary).

- K28-5.ptrn

This pattern is used to test Fiber Channel and Gigabit Ethernet elements. It tests random jitter (RJ) and deterministic jitter (DJ). The pattern is composed of 10 bits, followed by the complement of those 10 bits. It contains isolated characters preceded by runs of the opposite character. Disparity rules are followed.

11 00 00 01 01

00 11 11 10 10 (binary)

- JTPAT.ptrn

This is a Fiber Channel jitter tolerance pattern, used to test receiver CDR to large instantaneous phase jumps.

- D21-5.ptrn

This pattern is used to test Fiber Channel and Gigabit Ethernet elements. It tests random jitter (RJ) and the symmetry of logic transitions. The pattern is composed of alternating logic highs and lows and is repeated continuously. Disparity rules are followed.

1010101010

1010101010 (binary)

- CSPAT.ptrn

This Fiber Channel supply noise (SPAT) pattern is packaged into a Fiber Channel frame for use in system level tests.

- CRPAT.ptrn

This Fiber Channel Compliant (RPAT) pattern for jitter generation is packaged into a Fiber Channel frame.

- CJTPAT.ptrn

This Fiber Channel Compliant (JTPAT) pattern for jitter tolerance is packaged into a Fiber Channel frame.

PRBS This directory contains PRBS patterns that have different lengths and mark densities:

- PRBS7_1-8.ptrn
- PRBS7_2-8.ptrn
- PRBS7_1-2.ptrn
- PRBS7_6-8.ptrn
- PRBS7_7-8.ptrn
- PRBS10_1-8.ptrn

- PRBS10_2-8.ptrn
- PRBS10_1-2.ptrn
- PRBS10_6-8.ptrn
- PRBS10_7-8.ptrn
- PRBS15_1-8.ptrn
- PRBS15_2-8.ptrn
- PRBS15_1-2.ptrn
- PRBS15_6-8.ptrn
- PRBS15_7-8.ptrn
- PRBS23_1-8.ptrn
- PRBS23_2-8.ptrn
- PRBS23_1-2.ptrn
- PRBS23_6-8.ptrn
- PRBS23_7-8.ptrn
- PRBS7-1_1-2.ptrn

TIP

The file names indicate how the patterns are configured. For example, PRBS23_6-8.ptrn has a pattern length of 2^{23} (8,388,608) bits and a mark density of 3/4 (6/8 or 75 percent).

NOTE

PRBS7-1_1-2 is an emulation of a hardware-generated PRBS 2^7 pattern with a mark density of 50 percent.

SDH CID This directory contains the following pattern:

- SDH_STM-16_CID.ptrn

Pattern is a SDH STM-16 rate Consecutive Identical Digit (CID) pattern, same length as a SDH frame with nine bytes of all 1s and nine bytes of all 0s separated by random data. This implementation uses one SDH "frame" to carry the CID pattern as follows: A1, A2, and C1 bytes as per a normal frame, followed by a block of bytes set to all 1s, then the normal scrambler sequence (2^7 PRBS) starting with 1111 111. Half way through the frame, at row 5 column 40, an A1, A2, and C1 sequence is inserted again followed by a block of bytes set to all 0s, then the normal scrambler sequence starting with 1111 111 again. The length is 148,992 bits (STM-16) corresponding to a time constant of about 4 msec.

2 Setting up Patterns

- SDH STM4**
- SDH STM-4.ptrn
A standard SDH STM-4 frame and payload. Total pattern length of 77,760 bits.

- SDH STM16** All patterns are STM-16 SDH frame, standard pattern, scrambler ON, and 1010... payload:
- SDH_STM-16.ptrn
Pattern contains no errors or alarms
 - SDH_STM-16_HP-BIP.ptrn
Pattern for testing frames with erred parity check sums, (B3) error
 - SDH_STM-16_HP-REI.ptrn
Pattern for testing Remote Error Indication (REI) alarm
 - SDH_STM-16_MS-AIS.ptrn
Pattern for testing Alarm Indicator Signals (AIS) alarm
 - SDH_STM-16_MS-BIP.ptrn
Pattern for testing frames with erred parity check sums, (B2) error
 - SDH_STM-16_MS-RDI.ptrn
Pattern for testing Remote Defect Indication (RDI) alarm
 - SDH_STM-16_OOF.ptrn
Pattern for testing Out of Frame (OOF) alarm
 - SDH_STM-16_RS-BIP.ptrn
Pattern for testing frames with erred parity check sums, (B1) error

- SDH STM16 alternate** All patterns are alternate. Pattern A is an error and alarm free SDH STM-16 frame, scrambler ON, and 1010...payload. Pattern B has either an error or alarm as per below:
- SDH_STM-16_HP-BIP_alt.ptrn
Pattern for testing frames with erred parity check sums, (B3) error
 - SDH_STM-16_HP-REI_alt.ptrn
Pattern for testing Remote Error Indication (REI) alarm
 - SDH_STM-16_MS-AIS_alt.ptrn
Pattern for testing Alarm Indicator Signals (AIS) alarm
 - SDH_STM-16_MS-BIP_alt.ptrn
Pattern for testing frames with erred parity check sums, (B2) error

- SDH_STM-16_MS-RDI_alt.ptn
Pattern for testing Remote Defect Indication (RDI) alarm
- SDH_STM-16_OOF_alt.ptn
Pattern for testing Out of Frame (OOF) alarm
- SDH_STM-16_RS-BIP_alt.ptn
Pattern for testing frames with erred parity check sums, (B1) error

SDH STM64

- SDH STM-64.ptn
A standard SDH STM-64 frame and payload. Total pattern length of 1,244,160 bits

SONET CID

This directory contains the following pattern:

- SONET_STS-48_CID.ptn
Pattern is a SONET STS-48 rate Consecutive Identical Digit (CID) pattern, same length as a SONET frame with nine bytes of all 1s and nine bytes of all 0s separated by random data. This implementation uses one SONET "frame" to carry the CID pattern as follows: A1, A2, and C1 bytes as per a normal frame, followed by a block of bytes set to all 1s, then the normal scrambler sequence (2^7 PRBS) starting with 1111 111. Half way through the frame, at row 5 column 40, an A1, A2, and C1 sequence is inserted again followed by a block of bytes set to all 0s, then the normal scrambler sequence starting with 1111 111 again. The length is 148,992 bits (STS-48) corresponding to a time constant of about 4 msec.

SONET OC12

- SONET OC-12
A standard SONET OC-12 (STS-12) frame and payload. Total pattern length of 77,760 bits

SONET OC48

All patterns are SONET OC-48 (STS-48) frame, standard pattern, scrambler ON, and 1010... payload:

- SONET_STS-48.ptn
Pattern contains no errors or alarms
- SONET_STS-48_L-AIS.ptn
Pattern for testing Alarm Indicator Signals (AIS) alarm
- SONET_STS-48_L-BIP.ptn
Pattern for testing frames with erred parity check sums, (B2) error
- SONET_STS-48_L-FERF.ptn
Pattern for testing L-FERF alarm

2 Setting up Patterns

- SONET_STS-48_OOF.ptrn
Pattern for testing Out of Frame (OOF) alarm
- SONET_STS-48_P-BIP.ptrn
Pattern for testing frames with erred parity check sums, (B3) error
- SONET_STS-48_P-FEBE.ptrn
Pattern for testing P-FEBE alarm
- SONET_STS-48_S-BIP.ptrn
Pattern for testing frames with erred parity check sums, (B1) error

SONET OC48 alternate All patterns are alternate. Pattern A is an error and alarm free SONET OC-48 (STS-48) frame, scrambler ON, and 1010...payload. Pattern B has either an error or alarm as per below:

- SONET_STS-48_L-AIS_alt.ptrn
Pattern for testing Alarm Indicator Signals (AIS) alarm
- SONET_STS-48_L-BIP_alt.ptrn
Pattern for testing frames with erred parity check sums, (B2) error
- SONET_STS-48_L-FERF_alt.ptrn
Pattern for testing L-FERF alarm
- SONET_STS-48_OOF_alt.ptrn
Pattern for testing Out of Frame (OOF) alarm
- SONET_STS-48_P-BIP_alt.ptrn
Pattern for testing frames with erred parity check sums, (B3) error
- SONET_STS-48_P-FEBE_alt.ptrn
Pattern for testing P-FEBE alarm
- SONET_STS-48_S-BIP_alt.ptrn
Pattern for testing frames with erred parity check sums, (B1) error

For more information on the recommended pattern for specific purposes, see [“When to Use Which Pattern?”](#) on page 26.

User Patterns - Procedures

You can do the following tasks in the **Edit Pattern** window:

- [“Creating New Patterns”](#) on page 39

- “Creating New Patterns” on page 39
- “Editing Patterns” on page 40
- “Saving Patterns” on page 40
- “Loading Patterns to the Pattern Generator and Error Detector” on page 41
- “Loading Patterns Directly from the Pattern Editor” on page 42

Creating New Patterns

To start a new pattern:

- 1 Press the **Edit Pattern on File** icon in the **Pattern** menu.



- 2 In the toolbar, click the **New** icon.



This opens the Pattern Properties dialog box, where you can:

- Enter a **Description** for the pattern
- Specify the pattern's **Length in Bits**
- Specify the pattern's **Pattern Type** (**Standard** or **Alternate**)

- 3 After you have entered these parameters, click **OK**.

The pattern is then opened in the **Edit Pattern** window.

- 4 You can now continue with modifying the pattern according to your needs.

Opening Existing Patterns

To open an existing user pattern:

- 1 Press the **Edit Pattern on File** icon in the **Pattern** menu.



- 2 In the toolbar, click the **Open** icon.



The **Select User Pattern** dialog box opens.

- 3 Use this dialog box to locate and open the desired pattern. You can select files of the following types:

2 Setting up Patterns

- 71630 BERT Pattern Files (*.dat)
- 86130A BitAlyzer Pattern Files (*.ptrn)
- ASCII Text Pattern Files (*.txt)

See “[Supported Pattern Types](#)” on page 28 for descriptions of these files.

Editing Patterns

To edit a user pattern:

- 1 Press the **Edit Pattern on File** icon in the **Pattern** menu.



- 2 If no pattern is loaded in the editor, first open a pattern file as described in “[Opening Existing Patterns](#)” on page 39 or create a new one as described in “[Creating New Patterns](#)” on page 39.
- 3 To change the pattern length or description or to switch between standard and alternating patterns, press the **Properties** button.



The **Pattern Properties** dialog box appears.

- 4 Define the pattern length, whether it is alternate or standard, and give it a description. Click **OK** when finished.
- 5 Edit the pattern as required. For the function of the different tool buttons, see “[Edit Pattern Window](#)” on page 43.

Saving Patterns

To save the current user pattern:

- In the toolbar, click the **Save** icon.



If the pattern has already been saved earlier, the saved file is updated. Otherwise, the Windows standard **Save As** dialog box opens, where you can define the file's path and name.

The available file formats to save the file in are:

- Pattern File (*.ptrn) in binary (8 bits/byte), hex (4 bits/byte), or 01 (1 bit/byte) format
- ASCII Pattern Files (*.txt)

See “[Pattern File Specifications](#)” on page 28 for descriptions of these file types.

If you want to save the pattern file in one of the 12 memory slots, use the file names from `UPAT1.ptrn` through `UPAT12.ptrn` respectively.

Loading Patterns to the Pattern Generator and Error Detector

The recommended way to load the data patterns to the pattern generator and error detector is to use the **Pattern Select Form** dialog box.

- 1 Press the **Pattern Select** icon in the **Pattern** menu.



The **Pattern Select Form** dialog box opens.

- 2 Select one of the following pattern types for the pattern generator, and follow the next required action as listed below.

Table 4

Pattern Type	Next Required Action
User Pattern	Browse for the desired pattern file.
Memory User Pattern	Select memory slot (1 - 12).
$2^n - 1$ PRBS	Select the pattern size.
2^n PRBS	Select the pattern size.
Mark Density	Select the pattern size and the mark density ratio.
Zero Sub	Select the zero substitution rate.
Sequence	Enable this checkbox if you intend to download a user-defined sequence. Patterns generated within a sequence are defined in the Sequence Editor.

NOTE

Your instrument also contains user patterns that mimic real data packets and are designed to stress specific characteristics of your device. For more information, see “[Example Patterns](#)” on page 33.

2 Setting up Patterns

- 3 If you want to select a different pattern for the error detector, clear the checkbox **Error Detector Pattern tracks the Pattern Generator Pattern**. The **Error Detector Pattern** tab appears. Switch to this tab and repeat step 2.
- 4 Click **OK** to finish.

The selected patterns are immediately loaded to the pattern generator and error detector. The types of patterns that are currently loaded to the pattern generator and the error detector are always displayed in the lower left corner of the screen.

Loading Patterns Directly from the Pattern Editor

After you have finished editing a pattern in the pattern editor, you can load this pattern directly to the pattern generator and error detector.

NOTE

Keep in mind that your modifications in the Pattern Editor do not affect the pattern at the pattern generator or error detector until you download the pattern to the pattern generator/error detector.

- 1 First determine whether the pattern generator and error detector should use the same pattern. Press the **Pattern Select** icon in the **Pattern** menu.



The **PatternSelectForm** dialog box opens.

- 2 Select **Error Detector Pattern tracks the Pattern Generator Pattern** if you want both modules to receive the same pattern.
- 3 Click **OK** to close this dialog box.
- 4 The pattern editor now displays the following buttons in the toolbar:

If you chose that both the error detector and pattern generator use the same pattern:

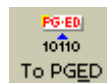

Loads the current pattern to both the pattern generator and error detector.

If you allowed different patterns for the two modules:



Loads the current pattern to the pattern generator.



Loads the current pattern to the error detector.



Captures data of specified length from the error detector.

NOTE

Once the pattern of a specific length is captured from the error detector, it can be sent back to the error detector and the pattern generator. For later use of this captured pattern it should be saved using "SaveAs" option. The user will be prompted to save the captured pattern if a new pattern is loaded, and the same pattern is recaptured.



User Patterns - Reference

The elements of the pattern editor and all dialog boxes that can be opened from the pattern editor are described below:

Edit Pattern Window

The **Edit Pattern** window provides the following convenient pattern editing functions:

Table 7

Icon	Name	Description
	Toolbar Ctrl	Click this icon to switch the toolbar from two rows to a single row appearance, leaving more space for the pattern data.
	New	Click this icon to create a new pattern. See "Creating New Patterns" on page 39 for details.

2 Setting up Patterns

Table 7











Icon	Name	Description
	Open	Click this icon to open a pattern from a file. See “Opening Existing Patterns” on page 39 for details.
	Save	Click this icon to save the current pattern. If it was not previously saved, a Save As dialog box opens for you to specify name and path for the file.
	To PG	Click this icon to send the pattern from the editor to the pattern generator.
	To ED	Click this icon to send the pattern from the editor to the error detector.
	To Pattern Capture	Click this icon for Pattern Capture. See “Pattern Capture Dialog Box” on page 48 for details.
	To PGED	Click this icon to send the pattern from the editor to the pattern generator and the error detector.
	Cut/ Copy/ Paste/ Delete/ Undo	These functions follow Microsoft Windows conventions.

Table 7

Icon	Name	Description
	Go To	Click this icon if you want to jump to an arbitrary bit position. See “GoTo Bit Dialog Box” on page 47 for details.
	INS/ OVR	Click this icon to toggle between the insert and overwrite editing mode: With Insert mode you insert bits at the cursor position, shifting the rest of the pattern to the right. With Overwrite mode you overwrite the bits at the cursor position.
	Hex/ Bin	Click this icon to toggle between viewing the pattern in hex or binary mode.
	Properties	Click this icon to change the properties of the current pattern. See “Pattern Properties Dialog Box” on page 47 for details.
	Find	Click this icon to open the Find Pattern Segment dialog box and search for a specified segment in the pattern. See “Find Pattern Segment Dialog Box” on page 48 for details.

Table 7

Icon	Name	Description
	Insert	Click this icon to insert a block of data in the pattern at the current cursor position. See “Insert Block Dialog Box” on page 49 for details.
	Select All	Click this icon to select all the bits in the pattern.
	Alt Pat View	Click this icon repeatedly to view alternating patterns in the following ways: <ul style="list-style-type: none"> - Pattern A only - Patterns A and B in interleaved rows - Patterns A and B in horizontally split windows <p>If only a standard pattern is selected, this icon has no function.</p>
	Pat Sel	Click this icon to open the Pattern Select Form dialog box. For more information, see “Loading Patterns to the Pattern Generator and Error Detector” on page 41 .

TIP

If you are working on a remote PC, you can use the keyboard shortcuts for Cut, Copy, and Paste. Also, you can use the clipboard function to copy strings in either binary or hex format to and from other applications. When pasting them into the pattern in binary view, a 1 sets a single bit, in hex view, a 1 sets 4 bits.

Pattern Editor Canvas and Status Bar

The pattern editor canvas displays the pattern and offers you to edit it.

Address	
0	0 7 8 1 3 5 8 0 3 0 A D 4 0 6 D 5 4 E 0
80	F 0 8 6 5 4 D 6 5 C 0 D 5 6 5 4 0 E 0 F
160	6 5 7 9 8 7 3 2 1 0 9 8 3 1 9 8 7 1 8 6
240	C 8 7 0 A D B E F 1 0 C 5 6 2 0 A 5 D 4
320	E D 0 6 5 C + 0 0 5 8 6 5 4 0 8 5 6 A 6
400	5 E 4 0 D E 6 5 + F 0 6 5 4 0 6 1 1 1 7
480	8 3 2 1 F 0 E 8 D O E S 6 D 3 2 1 9 7 6
560	2 0 3 E D + 9 8 7 0
640	
720	

Offline Position: 484 Overwrite Hex MD: 0.4300 Length: 600

The status bar below the editor canvas provides the following information from left to right:

- Status **Offline**, indicating that this is the display of the editor, not the pattern generator nor the error detector
- Current **Position** in bits of the cursor in the pattern
- Editing mode (**Overwrite** or **Insert**)
- Display mode (**Hex** or **Bin**)
- Mark Density of the pattern(s)
- Total **Length** of the pattern (in bits)

The available functions to change the view and to modify the pattern are described in [“Edit Pattern Window” on page 43](#).

GoTo Bit Dialog Box

This function allows you to set the cursor to an arbitrary position in the pattern. Enter the bit position (=address) and click **Go!**. The cursor is placed in front of the character with the selected bit. You can continue editing the pattern while this dialog box is still open.

Pattern Properties Dialog Box

The **Pattern Properties** dialog box always opens when you create a new pattern. It can also be used to view or change the attributes of the currently selected pattern.

TIP

You can use your instrument's software keyboard to enter text in the dialog box. For more information, see [“Using the On-Screen Keyboard” on page 402](#).

Description This text field allows you to enter a description of the pattern's characteristics or purpose. It can be up to 256 characters long.

2 Setting up Patterns

Pattern Type Select **Standard** if you want to use this pattern as a standard pattern. Select **Alternate** if you want to define two alternating patterns A and B.

Length in Bits This text field allows you to enter the pattern length.

To find out more about appropriate pattern lengths, see [“Pattern Resolutions and Lengths”](#) on page 30.

Pattern Capture Dialog Box

The pattern capture screen has four fields as shown in the screen below.

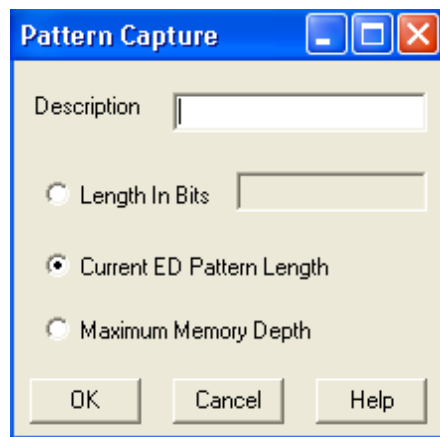

Description Description for the captured Pattern.

Length in Bits Pattern capture length in bits.

Current ED pattern length Captures the entire pattern length of currently loaded pattern in the error detector.

Maximum Memory Depth Captures the maximum (32Mbit) pattern length of currently loaded pattern in the error detector.

Find Pattern Segment Dialog Box

The **Find Pattern Segment** dialog box allows you to search for a specified bit sequence in the pattern. If you click **Next**, the next occurrence of this bit sequence is highlighted.

The search pattern can be entered in either hex or binary format, independently of the currently displayed format in the pattern editor. You can continue editing the pattern while this dialog box is still open.

- Next** Looks for the next occurrence of the pattern from the current position to the end. If there is no further occurrence, the current selection does not change.
- Done** Click this button to close the dialog box.

Insert Block Dialog Box

The **Insert Block** function provides an easy way to modify parts of the pattern or the entire pattern at once. This can be used when setting up a new pattern. It can also be used as an optional technique for editing existing patterns.

With the **Insert Block** dialog box, you define the **Range** that is to be modified and an **Action** that will be done to this range.

The available options for the **Range** are:

- **Select All**
Choose this option to select the entire pattern for editing.
- **Range**
Choose this option to select the range of bits specified by the bit positions entered in the **From** and **To** fields.
- **Fill From Cursor to End**
Choose this option to select the bits from the cursor location to pattern end.
- **Fill From Start to Cursor**
Choose this option to select the bits from pattern start to the cursor.

The available options for the **Action** are:

- **0101...0101**
Choose this option to fill the range with alternating highs and lows.
- **Invert Bits**
Choose this option to invert the high/low logic in the range.
- **All Zeros**
Choose this option to fill the range with all logic lows.
- **All Ones**
Choose this option to fill the range with all logic highs.

Status Bar

The types of the patterns that are currently loaded to the pattern generator and the error detector are always displayed in the left half of the status bar at the bottom of the screen.



Select Pattern Dialog Box

This dialog box lets you define the pattern you want to use for testing. It contains the following elements:

Error Detector Pattern Tracks the Pattern Generator Pattern

With this checkbox you can determine whether both pattern generator and error detector use the same data pattern.

If you clear this checkbox, the **Error Detector Pattern** tab appears, where you can select a different pattern for the error detector.

The checkbox is automatically cleared when you load a user-defined sequence to the pattern generator. See [“Sequence Mode Characteristics” on page 58](#) for details.

Pattern Types

You can choose between the following types of patterns:

- **User Pattern from File**

With this option, you can load a pattern that is stored in a file. Use the **Browse** button to select the desired file.

- **Memory User Pattern**

The Serial BERT supports 12 so-called memory slots for storing user patterns. The slots are stored in files named `Upat1.ptrn` to `Upat12.ptrn`. To load a pattern that is stored in one of these memory slots, choose this option and select the desired slot from the list.

- **2ⁿ -1 PRBS**

Select this option to use a hardware-generated pattern of length 2ⁿ-1. See [“How the Hardware Generates PRBS” on page 54](#) for details.

- **2ⁿ PRBS**

Select this option to use a memory-based pattern of length 2ⁿ.

- **Mark Density PRBS**

Use this options to generate memory-based 2ⁿ PRBS patterns with specified mark densities. Select the desired value from the list. The available values are **1/8**, **1/4**, **1/2**, **3/4**, and **7/8**.

- **Zero Sub PRBS**

Use the Zero Substitution function to insert a longer row of zeros into a memory-based 2^n PRBS pattern. The length of the zero row can be freely specified up to the length of the pattern.

Pattern Size You can select the pattern size according to your needs. The pattern lengths available depend on the type of signal you have selected.

Sequence Enable this checkbox if you wish to use a user-defined sequence. The patterns used in a sequence are defined in the **Sequence Editor** (see also “[User-Defined Sequences - Concepts](#)” on page 56).

Bit Recovery Mode / BRM Only available on the **Error Detector Pattern** page. Enables the error detector's bit recovery mode. For details see “[Understanding Bit Recovery Mode](#)” on page 128.

Software-Generated PRBS

Software-Generated PRBS - Concepts

Software-generated patterns are PRBS patterns that can be modified. They are calculated by the Serial BERT software and then loaded to the memory, from which the necessary output is generated. As such, they are closely related to user patterns, with the exception that they cannot be edited in the **Pattern Editor** window.

When to Test with Software-Generated PRBS

You can use these patterns for any application where random data and an even number of bits is required.

In addition, you can vary the mark density or zero substitution to test the influence on the BER. This allows potential problems like baseline wander, for instance, to be fully characterized.

How the Software Generates PRBS

When you set up a software-generated pattern, the Serial BERT calculates the required pattern and loads this into the memory. From

here, the memory is read bit by bit (identically as for memory-based patterns), and the corresponding output is generated.

See also “How the Serial BERT Generates Memory-Based Patterns” on page 31.

Range of Software-Generated PRBS Patterns

The Serial BERT supports the following 2^n PRBS patterns:

Table 8

n	Sequence Length	Longest Run of 1's	Longest Run of 0's
7	128	7	7
10	1,024	10	10
11	2,048	11	11
13	8,192	13	13
15	32,768	15	15
23	8,388,608	23	23

Zero Substitution Patterns

A potential risk to bit errors are longer rows of zeros within a data stream. The longest run of zeros in a 2^n PRBS consists of n zeros.

The Zero Substitution function can be used to stress the DUT additionally by inserting a longer row of zeros in the data stream. The length of the zero row can be freely specified, up to the length of the pattern.

The following figure shows an example, where a run of 10 zeroes is inserted into a PRBS 2^7 pattern.

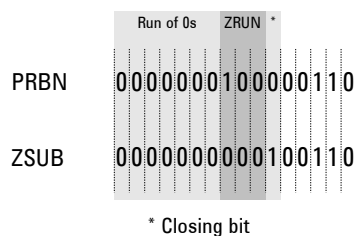

Mark Density Patterns

The mark density of a pattern is the portion of bits that are ones.

A pure PRBS pattern contains an equal number of ones and zeros and, thus, has an average voltage in the center between high and low level. Therefore, the mark density of such a pattern is 1/2.

Some devices may have problems processing data streams with different mark density as this results in other average voltages and, thus, different electrical conditions.

The ones (mark) density can be varied to put the pattern out of balance in a randomly distributed way. This may be useful for systems that are AC-coupled. This helps to check for effects such as baseline wander.

To test these cases, the Serial BERT provides PRBS patterns with the mark densities 1/8, 1/4, 1/2, 3/4, and 7/8.

Software-Generated PRBS - Procedures

The recommended way to load the data patterns to the pattern generator and error detector is to use the **Pattern Select Form** dialog box.

See “[Loading Patterns to the Pattern Generator and Error Detector](#)” on [page 41](#) for details.

Software-Generated PRBS - Reference

Use the **Pattern Select** dialog box to select the pattern(s) you want to write to the pattern generator and the error detector. See “[Select Pattern Dialog Box](#)” on [page 50](#) for details.

Hardware-Generated PRBS

Hardware-Generated PRBS - Concepts

This section describes the basics of hardware-generated PRBS $2^n - 1$ patterns.

When to Test with Hardware-Generated PRBS Patterns

You can use the Serial BERT's hardware-generated PRBS patterns if you require simple random traffic for testing your device. The $2^n - 1$ odd pattern lengths are not related to the divided clock rate. When using an oscilloscope, this will ensure that the random contents of the bit stream is sampled.

The spectral contents of PRBS $2^n - 1$ patterns and the special property of decimation may also be useful in many applications (for example, for multiplexer or demultiplexer testing).

How the Hardware Generates PRBS

$2^n - 1$ PRBS is an inverted, hardware-generated pattern that is created by a series of shift registers with adjustable feedback. The example below shows the register configuration for a $2^7 - 1$ (127-bit) pattern.

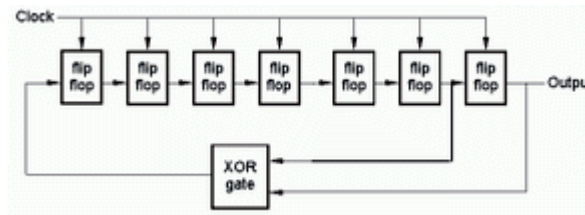

The following table describes the operation of XOR'ing two points for the different patterns.

Table 9

Sequence Length	Shift-Register Configuration
$2^7 - 1$	$D^7 + D^6 + 1 = 0$, inverted
$2^{10} - 1$	$D^{10} + D^7 + 1 = 0$, inverted
$2^{11} - 1$	$D^{11} + D^9 + 1 = 0$, inverted
$2^{15} - 1$	$D^{15} + D^{14} + 1 = 0$, inverted
$2^{23} - 1$	$D^{23} + D^{18} + 1 = 0$, inverted
$2^{31} - 1$	$D^{31} + D^{28} + 1 = 0$, inverted

Range of Hardware-Generated PRBS Patterns

PRBS Lengths The following table lists the hardware-generated $2^n - 1$ PRBS pattern lengths that correspond to different n values. This is before the pattern is finally inverted.

Table 10

n	Sequence Length	Longest Run of 1's	Longest Run of 0's
7	127	7	6
10	1,023	10	9
11	2,047	11	10
15	32,767	15	14
23	8,388,607	23	22
31	2,147,483,647	31	30

Decimation of PRBS Patterns

A special property of $2^n - 1$ PRBS patterns is that they can be demultiplexed into the same patterns at slower speeds with different phases. This is also true for multiplexing. The demux or mux must have n ports.

Hardware-Generated PRBS - Procedures

The recommended way to load the data patterns to the pattern generator and error detector is to use the **Pattern Select Form** dialog box.

See [“Loading Patterns to the Pattern Generator and Error Detector”](#) on page 41 for details.

Hardware-Generated PRBS - Reference

Use the **Pattern Select** dialog box to select the pattern(s) you want to write to the pattern generator and the error detector. See [“Select Pattern Dialog Box” on page 50](#) for details.

User-Defined Sequences

User-Defined Sequences - Concepts

This section describes the basics of user-defined sequences.

A sequence is created and maintained by means of the **Sequence Editor** that can be enabled from the Pattern window.

A sequence consists of up to four blocks. Each block can generate a pause signal (constant 0 or 1), a divided clock signal, a $2^n - 1$ PRBS, or a user pattern.

Single or multiple blocks can be looped. An overall loop restarts the sequence after it has come to its end.

When to Use a Sequence

You may wish to test a device that uses a certain protocol for processing data.

For example, the device might expect synchronization data, a preamble, payload data, and a suffix.

All this can be provided by a user-defined sequence.

How a Sequence is Defined

The sequence is defined by a SequenceExpression which is formulated in its own language, checked by the **Sequence Editor**.

The SequenceExpression specifies:

- the sequence start (and break) conditions
- the blocks, their contents, and trigger output
- the loops

You can inspect the contents of the SequenceExpression in the **Properties** dialog of the Sequence Editor.

The SequenceExpression uses the following keywords:

Version=	optional
Description=	optional
Start=	optional
Block #=	repeated for each block, numbered
Loop=	repeated for every loop, not numbered

Example of a SequenceExpression:

```
Version= 1.0
Start= IMM
Block 1= PRBS11, 1024, TrigOn
Block 2= C:\N4903A\Pattern\Upat10.ptrn
Block 3= P0, 512, TrigOff
Loop= B1, B1, 2
```

Start Options Default is IMM = immediately after downloading the sequence to the pattern generator. Other options are:

- **AuxInHi | AuxInLo:** Sequence starts when Auxiliary Input is high or low.
- **AuxInRising | AuxInFalling:** Sequence starts with a rising or falling edge at the Auxiliary Input.
- **Manual:** Sequence starts when the **Start** button is clicked.

Block Options Default is pattern P0 (Pause0), a length of 512 bits, and Trigger On. Other options are:

- **Patterns:** P1 (Pause1), undistorted PRBS, a user pattern from a file, or a fraction of the clock pulse (divider range: 2 ... 127).
- **Length:** Must be 512 bits or a multiple thereof. Shorter or longer user patterns are automatically repeated until the next 512-bit boundary is reached (see also [“How the Serial BERT Generates Memory-Based Patterns” on page 31](#)).
- **Trigger:** Refers to the pattern generator's Trigger Out port. If the Trigger Out is set up to generate a divided clock pulse, the block setting is ignored.

But if the Trigger Out is set to "Sequence Trigger" and the block to TrigOn, a trigger pulse is generated whenever the block starts or restarts. No trigger is sent if the block is set to TrigOff.

See ["Trigger Output - Procedures" on page 94](#) for information on how to set the mode of the Trigger Out port.

LOOP Options Default is one overall endless loop for the whole sequence.

- B_n, B_m : Define the start and end block of a user-defined loop.

Loops always define the transition from the end of a block to the beginning of the same or a previous block. It is not possible to jump into an existing loop. It is also not possible to specify loops within loops (except the default overall loop).

- Loop end condition: Default is an INFinite (endless) loop. Other options are:
 - AuxInHi | AuxInLo: Loop continues until Auxiliary Input is high or low.
 - AuxInRising | AuxInFalling: Loop continues until Auxiliary Input receives a rising or falling edge.
 - Manual: Loop continues until the **Break** button is clicked.
 - Counted loop: Loop repeats a specified number of times.

Sequence Mode Characteristics

When a sequence is executed, the pattern generator is in "Sequence Mode".

This mode differs from usual "Pattern Mode":

- Pattern-related triggers cannot be generated. In sequence mode, the Trigger Out port can produce either a continuous pulse (a fraction of the current clock pulse) or a trigger spike at the beginning of each block that is set to TrigOn. The duration of that spike depends on several conditions and is therefore undefined.
- Software-generated PRBS with polynomial 2^n cannot be referenced in a sequence.
- If several PRBS patterns shall be included, all have to use the same polynomial.
- Every sequence has to be downloaded to the pattern generator before it can be executed.
- Every sequence can be stored in a file and recalled from that file. However, the SequenceExpression does not include user patterns.

Recalling a sequence from its file may fail if the referenced user patterns are not available.

A recalled sequence is not automatically downloaded to the pattern generator.

- In sequence mode, the function "Error Dector Pattern tracks the Pattern Generator Pattern" is automatically disabled. You have to download the expected (payload) pattern to the error detector.
- During initialization of the sequence, pure zeros are sent.

User-Defined Sequences - Procedures

You can create a new sequence, save it in a file, or load a saved sequence from its file.

Creating a New Sequence

If you wish to create a new sequence:

- 1 Choose **Pattern** and open the **Sequence Editor**.



By default, the **Sequence Editor** shows one block that is automatically repeated. It has a length of 512 bits and generates Pause0 data (pure zeros).

- 2 Click the **Properties** icon.



In the **Properties** window, set:

- the sequence start condition
- the number of blocks contained in the sequence (1 to 4)

- 3 Click **Ok** to close the **Properties** window.
- 4 Specify the data to be generated during execution of a block.
 - Click the **Edit** button of the block.
 - Choose from the list. For example, you can select a PRBS polynomial or browse for a pattern file. A "None" block is completely ignored.

2 Setting up Patterns

- If necessary, change the block length. The block length of user patterns is derived from the file. Remember that such patterns are automatically repeated until a multiple of 512 bits is reached.
- Decide on Trigger On or Off. This setting becomes effective if the Trigger Out port is set to **Sequence Trigger** (trigger at block begin).

5 Create loops (if desired):

- Click the out-arrow of a block. A loop condition box labeled INF appears.
- Click the in-arrow of the same or a previous block. This closes the loop.
- Click the condition box and choose the appropriate break condition.

6 Download the sequence to the pattern generator and test it.



7 Save the sequence in a file for later re-use.

Saving the Sequence in a File

To save the present sequence under a new name:

- 1 In the toolbar, click the **Save As** icon.



- 2 Select a suitable directory, for example C:\N4903a\Sequences.

- 3 Enter a file name.

The filename extension is `.seq` by default.

If the present sequence was loaded from a file and edited, you can also click the **Save** icon. In this case, the saved file is updated.

Loading a Sequence From a File

To recall a sequence from a file:

- 1 In the toolbar, click the **Open** icon.



The **Open Sequence** dialog box opens.

- 2 Use this dialog box to locate and open the desired sequence. The browser shows all files with the suffix `.seq` in the selected directory.

NOTE

The sequence is shown in the **Sequence Editor**, but NOT automatically downloaded to the pattern generator. In contrast to loading a pattern from file, the download of a sequence requires an additional command.

User-Defined Sequences - Reference

The elements of the Sequence Editor and the dialog boxes that can be opened from the Sequence Editor are described below:

Sequence Block Display

A new sequence consists of one block that is infinitely repeated (looped). By default, this block has a length of 512 bits and generates a Pause0 signal (a continuous stream of zeros). All this is shown on the display.

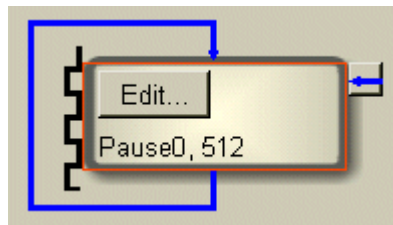

The vertical waveform at the left-hand side of the block indicates the setting of the pattern generator's Trigger Out port. By default, it generates a pulse, a subrate of the present clock. For information on how to change the trigger behavior, see [“Sequence Trigger at Block Begin” on page 62](#).

Number of Blocks

In the **Blocks** field, you can directly increase (or decrease) the number of blocks (range is 1 to 4).

2 Setting up Patterns

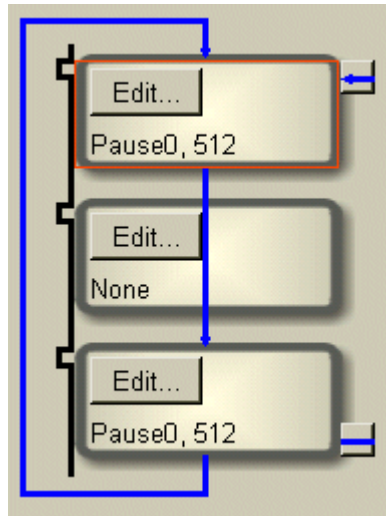

In this example, the number of blocks has been set to three. A "None" block generates no pattern and is completely ignored (indicated by a straight vertical blue line).

Sequence Trigger at Block Begin

After downloading the sequence to the pattern generator, you can also change the behavior of the Trigger Out port (for details see [“Sequence Trigger ” on page 95](#)):

In the example above, the Trigger Out port has been set to **Sequence Trigger** mode, and TrigOn is set for each block (as shown by the vertical trigger indicator).

Edit Button of a Block

To change the contents of a block, click its **Edit** button. This opens the **Set Data Block Parameter** dialog.

Sequence Block Parameters

The **Set Data Block Parameter** dialog allows you to change the contents and the trigger generation of a sequence block.

Block Contents Choices are:

- **None:** The block may be present in the sequence but is completely ignored.

- **Pause0:** Pure zeros are generated when the block is executed. You can change the block length, if desired.
- **Pause1:** Pure ones are generated when the block is executed. You can change the block length, if desired.
- **PRBS:** You can choose a PRBS of polynomial $2^n - 1$. The range of "n" is 7, 10, 11, 15, 23, or 31. You can change the block length, if desired.
- **Pattern:** You can open a browser and search for the file that contains the pattern. You can search for files with the extensions .ptrn, .txt, or .dat.

If the pattern file contains two alternate patterns, you can also specify whether the A or B pattern shall be generated (see also “[Pattern File Specifications](#)” on page 28). If the pattern file contains just one pattern, your choice is ignored.

You cannot change the block length. It shows the length of the pattern as stored in the file.

If the pattern length is not 512 bits or a multiple of 512 bits and this single block is looped, the behavior depends on the loop end condition.

If the loop end condition is INFinite or determined by the Aux In port, then the pattern is automatically repeated until 512 bits or a multiple thereof is reached.

In this case, the duration of the block will be longer than indicated. For example, a pattern containing 17 bits will be repeated 512 times and the actual block length will be 8704 bits. This has an impact on the trigger at block start.

Block Trigger If this checkbox is enabled, a trigger spike will be output at the pattern generator's Trigger Out connector whenever the execution of the block begins, provided that the Trigger Out port is set to **Sequence Trigger** mode (see also “[Sequence Trigger](#)” on page 95).

Loops Within a Sequence

A loop defines the transition from the end of a block to the beginning of the same or a previous block. It is not possible to jump into an existing loop. It is also not possible to specify loops within loops (except the default overall loop).

For information on how to create a loop, see “[Creating a New Sequence](#)” on page 59.

2 Setting up Patterns

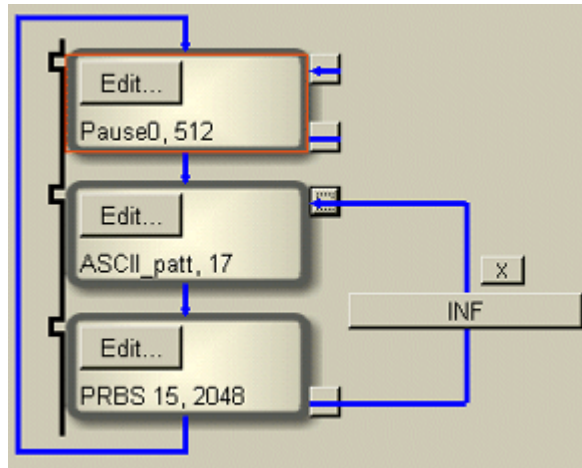

Every loop has a delete button [X] and a loop condition button.

Loop Delete Button Clicking the delete button [X] removes the loop from the sequence.

Loop End Condition Button The initial (default) setting of the loop end condition is INF(inite), which means, this loop will continue until the instrument is switched off. Clicking the loop end condition button allows you to specify the loop end condition.

Choices are:

- **Counted:** The loop ends after the specified number of repetitions. Sequence execution continues with the next block.
- **Infinite:** An infinite loop can be broken by:
 - **Aux In High | Aux In Low:** The loop ends when Auxiliary Input is high or low. Sequence execution continues with the next block.
 - **Aux In Rising | Aux In Falling:** The loop ends when a rising or falling edge at the Auxiliary Input is detected. Sequence execution continues with the next block.
 - **Manual:** The loop ends when the **Break** button of the Sequence Editor is clicked. Sequence execution continues with the next block.

NOTE

The pattern generator reacts on the end condition as soon as the pattern has finished.



Sequence Editor Toolbox

The Sequence Editor toolbox provides the following functions:

Table 12

Icon	Name	Description
	New	Click this icon to create a new sequence. This opens the Properties dialog. See “Creating a New Sequence” on page 59 for details.
	Open	Click this icon to open a sequence from a file. See “Loading a Sequence From a File” on page 60 for details.
	Save	Click this icon to save the current sequence in its original file.
	Save As	Click this icon to save the current sequence in a new file. A Save As dialog box opens for you to specify name and path for the file. See “Saving the Sequence in a File” on page 60 for details.
	To PG	Click this icon to download the sequence from the Sequence Editor to the pattern generator.
	From PG	Click this icon to upload the present sequence from the pattern generator to the Sequence Editor. This allows you to inspect and edit a sequence that has been loaded with a program.

Table 12

Icon	Name	Description
	Properties	Click this icon to change the properties of the current sequence. See “Setting Sequence Properties” on page 66 for details.
	Break	Click this icon to terminate an infinite loop that is set to "manual" break condition. Sequence execution continues with the next block.
	Resume	<p>Click this icon to interrupt and re-initialize a running sequence.</p> <p>If the sequence start condition is IMMEDIATE, the sequence restarts immediately.</p> <p>If the sequence start condition is a signal at the Aux In port, the sequence restarts upon the specified signal.</p> <p>If the sequence start condition is "Command", sequence execution starts when the Start button is clicked.</p>

Setting Sequence Properties

For a sequence, you can specify the following:

Sequence Start Condition Choices are:

- **Immediate:** Sequence starts immediately after downloading it to the pattern generator.

- **Aux In High | Aux In Low:** Sequence starts when Auxiliary Input is high or low.
- **Aux In Rising Edge | Aux In Falling Edge:** Sequence starts with a rising or falling edge at the Auxiliary Input.
- **Command:** The Sequence Editor shows a **Start** button. Sequence execution starts when this button is clicked.

Number of Blocks A sequence can contain 1 to 4 blocks.

Description A field for entering and editing descriptive text.

Sequence Expression A window that shows the present SequenceExpression (for details see [“How a Sequence is Defined” on page 56](#)).

You can edit the SequenceExpression in this field. Any changes override the previous settings.

NOTE

If you edit the SequenceExpression manually, take care to adhere to the syntax and order of the keywords.

Remember that you must download the updated sequence to the pattern generator if your changes shall take effect.

Start Button

The **Start** button of the Sequence Editor indicates that the sequence has been set up for manual start.

Click this button to start the sequence execution.

2 Setting up Patterns

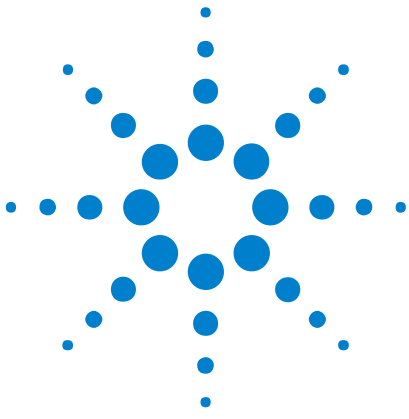

3 Setting up the Pattern Generator

Setting up the Pattern Generator - Concepts

The Serial BERT's pattern generator generates an output signal based on a data pattern. It has the following possibilities for generating an output signal:

- Providing a wide range of clock frequencies

You can use the pattern generator's internal clock or an external clock for defining the frequency of the outgoing stream.

- Distorting the signal by adding jitter

You can connect an external delay control device (for example a function generator) to add jitter to the generated signal.

- Adding errors to the output stream

The Serial BERT can be set up to insert errors into the outgoing stream either internally, according to an external signal, or manually (from the operator).

- Run-time switching between two patterns

You can set up two patterns and switch between them during runtime either automatically, according to an external signal, or manually.

- Suppressing the output stream

The output signal can be suppressed according to an external signal.

The pattern generator also provides output ports that let you connect an external instrument, such as an oscilloscope.



Input and Output Ports

Input and Output Ports - Concepts

Input Ports The pattern generator's *input* ports are used to set the pattern generator's clock frequency and to manipulate the output signal with respect to jitter, error insertion and signal output.

Output Ports The pattern generator's *output* ports are used to supply a clock signal and trigger for another device (for example, for the Serial BERT's error detector), and an arbitrary data signal for testing your device.

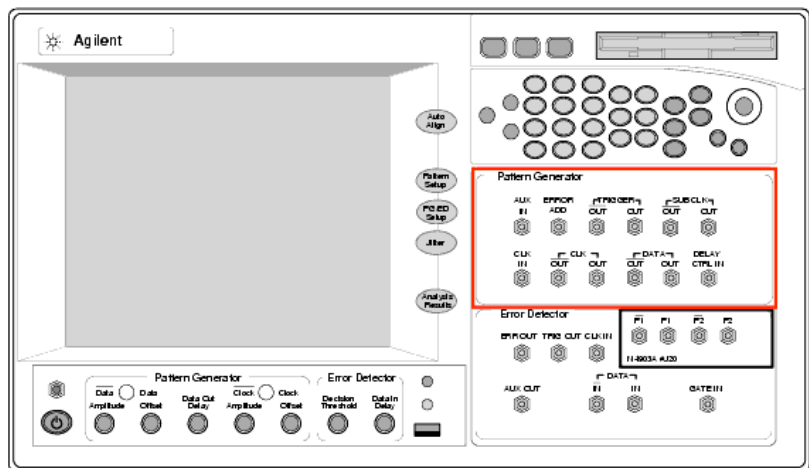

The pattern generator has the following inputs and outputs:

Understanding the Pattern Generator's Input Ports

The pattern generator provides the following input ports:

- 10 MHz Ref In

This connector allows you to connect a 10 MHz reference clock. The Serial BERT has a 10 MHz Ref In and Out port at the rear (two BNC connectors).

- Clock In

Allows you to connect a clock signal from another device.

- Error Add

Allows you to connect a device that generates a trigger for inserting a single bit error in the output stream.

- Delay Control In

Allows you to connect a signal for generating jitter in the data outputs.

- Aux In

The signal at the Aux In port can be used to switch between patterns A and B or to "blank" (suppress) the output signal. When a user-defined sequence is executed, it can also be used to control the sequence execution.

Understanding the Pattern Generator's Output Ports

The pattern generator provides the following output ports:

- Data Out and $\overline{\text{Data Out}}$

The data outputs serve as device stimuli and can be set up so that they are compatible with a variety of logic families. With respect to Data Out, $\overline{\text{Data Out}}$ has inverted logic.

- Clock Out and $\overline{\text{Clock Out}}$

The clock outputs serve as frequency (bit rate) references and can be set up so that they are compatible with a variety of logic families. With respect to Clock Out, $\overline{\text{Clock Out}}$ has inverted logic.

- Trigger Out and $\overline{\text{Trigger Out}}$

This port allows you to connect a trigger for another device (for example, an oscilloscope).

- Sub Clock Out and $\overline{\text{Sub Clock Out}}$

This port allows you to generate a pulse with a frequency that is a fraction of the present clock. Note that this output is not phase-synchronized with the clock.

The complementary outputs can be used when:

- additional output capability is needed for an instrument such as an oscilloscope or digital communication analyzer.
- your device requires differential inputs.

NOTE

The pattern generator's Data Out and Clock Out ports must be terminated with 50 Ω if they are not connected.

Understanding the Output Protection Algorithm

The generator module offers a huge flexibility for external termination schemes and external termination voltages to address common technologies. For details, please refer to the Technical Data Sheet.

An internal protection algorithm continuously monitors the voltages of clock and data output. It becomes active if the termination voltage is wrongly adjusted.

NOTE

The protection algorithm is not active if the termination voltage is higher than +1.5 V.

The protection algorithm sets the output voltages to safe levels:

- $V_{\text{high}} = \text{termination voltage} + 1 \text{ V}$
- $V_{\text{low}} = \text{termination voltage} + 0.9 \text{ V}$
- termination voltage remains unchanged

As soon as a 50 Ω load and the correct external termination voltage is detected again, the algorithm automatically switches back to the user-adjusted output levels. These changes are neither visible in the user interface nor can they be queried by a remote command.

Example:

User settings (with single ended operation):

Table 13

V_{high} [V]	V_{low} [V]	Term. [V]	Termination of	
			Out	$\overline{\text{Out}}$
+ 2	+ 1.2	- 0.5	50 Ω to - 0.5V	wrongly left open

An open condition is detected and the protection algorithm sets the following levels:

$$V_{\text{high}} = +0.5 \text{ V and } V_{\text{low}} = +0.4 \text{ V}$$

Next the complement output ($\overline{\text{Out}}$) is externally terminated with 50 Ω to GND. The protection circuit detects the correct external terminations and resets the voltages to the initial user settings:

$$V_{\text{high}} = +2 \text{ V and } V_{\text{low}} = +1.2 \text{ V}$$

Understanding the Output Level Parameters

The following figure shows the parameters of a data or clock output signal.

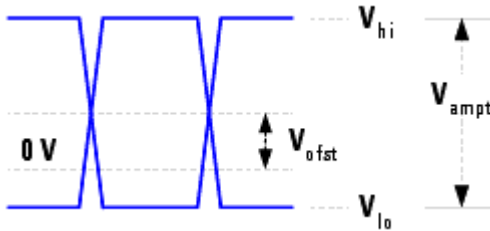

As shown in this figure, the signal output levels have the following components:

- V_{hi} is the upper voltage level of the signal.
- V_{lo} is the lower voltage level of the signal.
- V_{of} is the offset of the average voltage level from 0 V.
- V_{ampt} is the amplitude of the signal.

When adjusting the output levels, it is important to understand the concept of how the Serial BERT handles voltages.

Changing the Amplitude Typically, during tests, when you adjust the amplitude, you want to keep the offset constant. This keeps the ideal sampling point within the eye. The Serial BERT handles this by keeping V_{of} constant when V_{ampt} is changed.

Changing the Output Levels On the other hand, you may want to adjust the output voltage level without changing the amplitude. The Serial BERT handles this by keeping V_{ampt} constant when either V_{of} , V_{hi} , or V_{lo} is changed.

Voltage Level Restrictions The Serial BERT cannot generate a signal that has voltage levels out of range. If you try to enter a value for one parameter that would put another parameter out of limits, the Serial BERT rejects the change. This could happen, for example, if V_{lo} is already at the minimum, and you try to lower either of V_{hi} or V_{of} , or increase V_{ampt} .

Understanding Delay and Crossover

The Serial BERT provides the possibility of modifying the output data signal by varying the signal's delay to the clock signal, and the signal's crossover.

3 Setting up the Pattern Generator

Delay The exact time delay through a test setup can vary. The delay function allows you to compensate for this by adjusting the frequency reference for the data outputs. This varies the phase relationship of the data and clock outputs (causes the data pulse to have a certain time delay after the clock pulse). The higher the delay, the greater the time difference between the clock signal and the data signal.

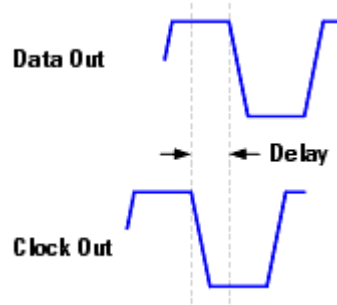

Crossover Crossover is the voltage level where the overlapped rising and falling edges of the logic levels intersect. This adjustment varies the widths of the logic highs and lows.

The following figure shows examples of crossover at 50 %, 80 %, and 20 %:

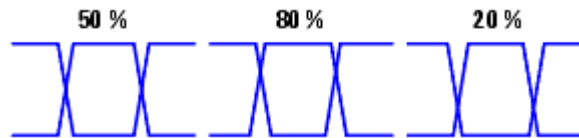

Understanding how the Serial BERT Uses Logic Families and Terminations

The clock and data inputs of your device have load impedances (or terminations). Clock and data terminations refer to the voltage levels at the end of these loads. These voltage levels are related to the logic family of your device. Your device should usually only receive signals that are compatible with its termination voltage and logic family.

When you change a logic family for the data or clock outputs, the termination voltage normally associated with the logic family is automatically selected. This is assumed to be the termination of your device, and will be used to determine the actual output voltage levels of the pattern generator.

CAUTION

If you manually change the termination, a warning message is shown, indicating that the termination is not typically appropriate for the logic family. If you answer No, the warning message closes with no changes to the terminations. If you answer Yes, the data termination voltage is applied and the Logic Level is changed to **CUSTOM**.

See also “Why Incorrect Terminations Could Damage Your Device” on page 76.

The following table lists the characteristics generally associated with some logic families. All values are nominal.

Table 14

Logic Family	V _{high} [V]	V _{low} [V]	Ampl. [mV]	Term. [V]
ECL	- 0.95	- 1.7	750	- 2
SCFL	0	- 0.9	900	0
LVPECL	+ 2.35	+ 1.6	750	+ 1.3
LVDS	+ 1.425	+ 1.075	350	+ 1.250
CML	0	- 0.4	400	0

Terms:

- **ECL**
Emitter Coupled Logic
- **SCFL**
Source Coupled FET Logic
- **LVPECL**
Low Voltage Positive Emitter Coupled Logic (PECL Lite)
- **LVDS**
Low Voltage Differential Signaling
- **CML**
Current Mode Logic

Why Incorrect Terminations Could Damage Your Device

Choosing wrong terminations may cause your device to output voltage levels that are not as expected. It may also cause excessive current or current flow in the wrong direction, which can damage your device.

Note that an internal protection algorithm becomes active if both the termination voltage is wrongly adjusted **and** the termination voltage is below +1.5 V. The protection algorithm sets the output voltages to safe levels:

- $V_{\text{high}} = \text{termination voltage} + 1 \text{ V}$
- $V_{\text{low}} = \text{termination voltage} + 0.9 \text{ V}$
- termination voltage remains unchanged

AC Coupling and Bias Tees

The pattern generator's outputs are normally DC-coupled; even when AC termination is selected. For this reason, extreme caution must be taken when connecting your instrument to a device or test setup.

The diagram below shows a device that is AC coupled. Notice that the capacitor is part of the test setup.

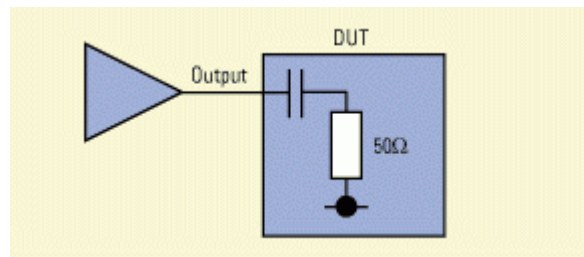

You can use an external bias network (also known as a *bias tee*) to power your device. You must ensure, however, that the network is oriented correctly. If it is not, damage may occur to your device or instrument.

The diagram below shows a *bias tee* that is positioned correctly. Notice that the pattern generator's outputs are protected by the blocking capacitor.

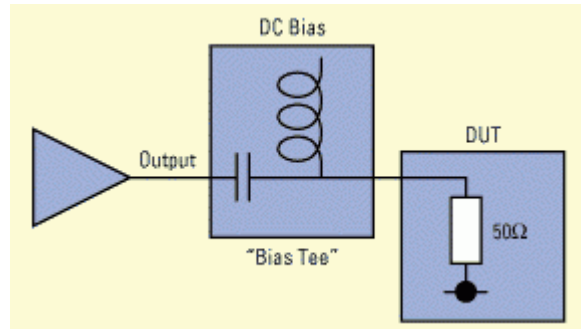

Understanding the N4916A De-Emphasis Signal Converter

The N4916A De-Emphasis Signal Converter can be connected between the Data Out port of the pattern generator and the DUT. It converts the generated rectangular NRZ signal to a de-emphasized differential signal.

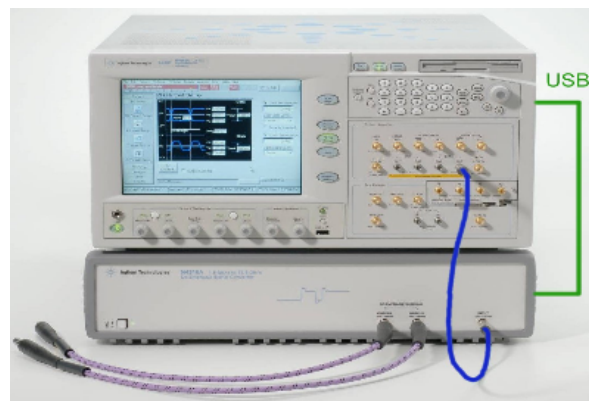

De-emphasized signals are used to adapt the signal waveform to the characteristics of real transmission lines as found on printed circuit boards. They can considerably reduce the impact of Intersymbol Interference (ISI) and hence allow longer signal paths. De-emphasized signals are prescribed by a couple of popular standards for high-speed data transmission.

3 Setting up the Pattern Generator

De-emphasis is a method that reduces the voltage of a digital signal if the generated level is high or low for more than one clock period. The principle is illustrated in the following figure.

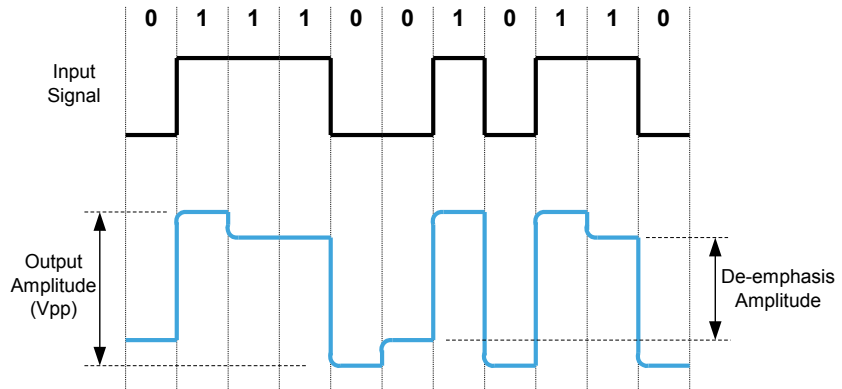

The de-emphasis amplitude is specified as a fraction of the output amplitude (in percent or dB). Both can be set in the **PG Output Setup** window of the Serial BERT.

When you **connect** the N4916A in the **PG Output Setup** window, the N4916A becomes completely transparent. Software adjusts the signal voltage produced by the pattern generator, so that the N4916A provides the indicated voltages to the DUT. This refers to V_{low} , V_{high} (or amplitude and offset), and termination. When you **disconnect** the N4916A in the same window, the data output voltages of the pattern generator are reset and it generates the specified and indicated voltages as usual.

The bit rate setting of the Serial BERT is automatically transmitted to the N4916A. Other functions of the pattern generator (for example, adding jitter) are not affected.

Post-cursor de-emphasis The figure above refers to a so-called post-cursor de-emphasis. You may wish to know how that is generated.

The N4916A De-Emphasis Signal Converter splits the incoming signal into two branches:

- One branch has a programmable amplifier to produce the desired output voltage (V_{pp}).
- The other one has an adjustable delay (automatically set to one signal clock period) and a programmable inverting attenuator/amplifier to produce the delayed signal with a lower voltage swing.

Finally, the signals of both branches are added. This means, the delayed signal voltage is subtracted from the specified peak-to-peak amplitude.

Pre-cursor de-emphasis It is also possible to convert the input signal to a pre-cursor de-emphasized signal.

This can be done by setting the output voltage swing to the desired de-emphasis amplitude and specifying a negative amplitude ratio (an amplification). This inverts the roles of the two branches. The delayed signal has now a larger amplitude than the direct signal. A waveform example is illustrated in the following figure.

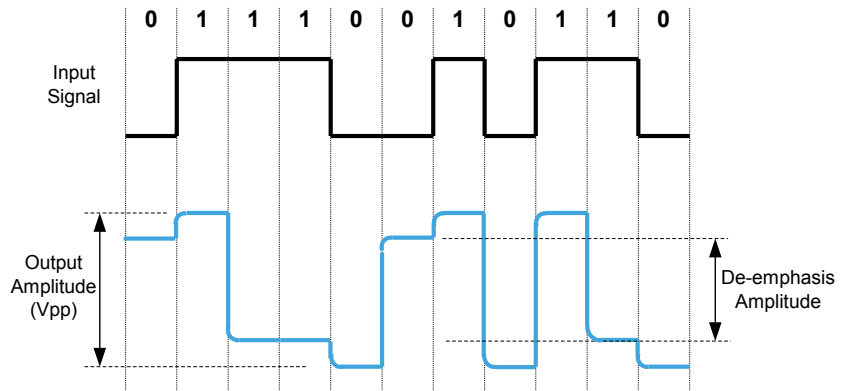

When pre-cursor de-emphasis is generated this way, the complementary Output of the N4916A becomes the normal output and vice versa.

CAUTION

Be very careful if you set the de-emphasis ratio to amplification! In this case, there is no indication of the peak-to-peak voltage applied to the DUT.

You need to calculate or measure the output signal voltage precisely. Otherwise you might damage your device.

Input and Output Ports - Procedures

You have to do the following to set up the pattern generator's output ports:

Setting Logic Levels and Terminations

Before you can start sending signals to your device, you have to set the logic levels and terminations:

- 1 Press **PG Output Setup** in the **PG Setup** menu.



- 2 In the **Data Logic Level** list, select the logic family that is appropriate for the data input of your device.

- 3 In the **Clock Logic Level** list, select the logic family that is appropriate for the clock input of your device.

When you modify the **Data Logic Level** or **Clock Logic Level**, the instrument automatically sets the appropriate voltage levels and the **Termination** voltage.

- 4 If necessary, change the data or clock termination voltage by entering a new value. You can also use the front panel knob to change the value.

The logic level automatically changes to **Custom**.

CAUTION

Selecting the wrong terminations may damage your device. See [“Why Incorrect Terminations Could Damage Your Device”](#) on page 76.

- 5 Connect the DUT's input ports to the Serial BERT's output ports.

CAUTION

Do not apply external voltages to the pattern generator outputs. For more information, see [“AC Coupling and Bias Tees”](#) on page 76.

Output ports of the pattern generator that are not connected to another device must be terminated with 50 Ohm to prevent the Serial BERT from damage.

Note that for unconnected ports, an internal protection algorithm automatically reduces the output voltages to safe levels.

Adjust Output Levels (optional)

Data and clock offset and voltage levels can be adjusted. This is typically done when you want to tune your BER measurement or stress the device.

You can use the knobs on the Serial BERT's front panel to fine-tune the data and clock amplitudes and offsets. If you want to set a specific value, you can use the numeric keyboard.

To enter specific values for the data and clock outputs from the keyboard:

- 1 Press **PG Output Setup** in the **PG Setup** menu to access the **PG Output Setup** window.



- 2 Click into the field you want to change.
- 3 Enter the desired voltage using the numeric keyboard or the respective front panel knob.

NOTE

If the termination voltage is wrongly adjusted or the output ports are not connected, an internal protection algorithm automatically sets the output voltage levels to safe levels. Connect the output ports or change the termination voltage before adjusting the output levels.

See “[Understanding the Output Level Parameters](#)” on page 73 for information about how the Serial BERT works with output level parameters.

Controlling the N4916A De-Emphasis Signal Converter

After the N4916A has been installed and physically connected to the Serial BERT and the DUT (see “[Installing the N4916A - Procedure](#)” on page 407), do the following:

- 1 In the **PG Setup** menu press **PG Output Setup** to access the **PG Output Setup** window.



- 2 Set the desired output levels and termination as described in or enter custom levels as described in “[Adjust Output Levels \(optional\)](#)” on page 80.
- 3 Press **De-Emphasis** to open the **De-Emphasis Connection** dialog window.

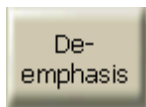

- 4 Press **Connect** to activate the connection between the Serial BERT and the N4916A.

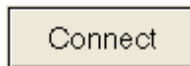

If you get an error message, refer to “[Cannot-Connect Problems](#)” on page 386.

NOTE

Once you have **connected** the pattern generator to the N4916A De-Emphasis Signal Converter, the Output Levels and Termination shown on the screen refer to the outputs of the N4916A.

Check the indicated signal levels. The output voltage range of the N4916A is lower than the range of the Serial BERT. The N4916A is first of all meant for low voltage amplitudes. If the N4916A cannot generate the specified signal voltages, they are reduced to safe levels. If this happens, you need to change the levels or the termination.

3 Setting up the Pattern Generator

- 5 Set the de-emphasis amplitude ratio to a value greater than zero. This defines the de-emphasis amplitude in relation to the data output amplitude. You can toggle between dB and percent.

CAUTION

Do not remove the connection cable between the pattern generator and the N4916A while the N4916A is in **connected** state (except for troubleshooting). In this mode, the output levels of the pattern generator are not shown on the screen and may present a hazard to your DUT (they have an amplitude of 1.2 V).

When you are done, press **Disconnect** to release the connection between the Serial BERT and the N4916A.

A rectangular button with a light beige background and a dark border, containing the text "Disconnect" in a dark font.

After that, the pattern generator will produce the specified voltage levels as usual. You can remove the connection cable between the pattern generator and the N4916A.

NOTE

It is possible to set the de-emphasis ratio to a negative dB value (an amplification). This allows you to generate a pre-cursor de-emphasis.

CAUTION

In this case there is a risk that you damage your device!

If you intend to generate a pre-cursor de-emphasized signal, refer to [“Understanding the N4916A De-Emphasis Signal Converter” on page 77](#) for the characteristics and dangers.

The following topics tell you how to use the pattern generator's input ports:

- [“Bit Rate - Procedures” on page 90](#)
- [“Delay Control Input - Procedures” on page 98](#)
- [“Manually Inserting Errors” on page 99](#)
- [“Setting Up a Periodical Output” on page 104](#)

Input and Output Ports - Reference

The pattern generator produces clock and data outputs that serve as frequency reference and device stimulus for the device under test.

NOTE

The Serial BERT will not allow you to adjust a voltage beyond its limits. The limit is determined by the Serial BERT's internal hardware. If a limit is encountered, the Serial BERT sends a message to the status bar. For more information about voltage limits, see the pattern generator's technical specifications.

Vhi

This text field allows manual entry of the logic high voltage level and displays the current value.

To modify the value, click inside the text field and either:

- Enter the desired value directly with the numeric keyboard.
- Use the knob by the numeric keyboard to fine-tune the value.

See [“Understanding the Output Level Parameters” on page 73](#) for information about how the Serial BERT modifies the output levels.

Vof

This text field allows manual entry of the voltage level halfway between logic high and logic low (the offset) and displays the current value.

To modify the value, click inside the text field and either:

- Enter the desired value directly with the numeric keyboard.
- Use the knob by the numeric keyboard to fine-tune the value.

TIP

You can also adjust V_{of} with the **Data Offset** knob on the front panel.

See [“Understanding the Output Level Parameters” on page 73](#) for information about how the Serial BERT modifies the output levels.

Vlo

This text field allows manual entry of the logic low voltage level and displays the current value.

To modify the value, click inside the text field and either:

- Enter the desired value directly with the numeric keyboard.
- Use the knob by the numeric keyboard to fine-tune the value.

See [“Understanding the Output Level Parameters” on page 73](#) for information about how the Serial BERT modifies the output levels.

V_{ampt}

This text field allows manual entry of the voltage amplitude and displays the current value.

To modify the value, click inside the text field and either:

- Enter the desired value directly with the numeric keyboard.
- Use the knob by the numeric keyboard to fine-tune the value.

TIP

You can also adjust V_{ampt} with the **Data Amplitude** knob on the front panel.

See [“Understanding the Output Level Parameters” on page 73](#) for information about how the Serial BERT modifies the output levels.

Delay

This text field allows manual entry of data output delay and displays the current value in picoseconds.

To modify the value, click inside the text field and either:

- Enter the desired value directly with the numeric keyboard.
- Use the knob by the numeric keyboard to fine-tune the value.

TIP

You can also adjust delay with the **Data Out Delay** knob on the front panel.

Xover

This text field allows manual entry of the crossover percentage, and displays the current value. To modify the value, click inside the text field and enter the desired value directly with the numeric keyboard or use the front panel knob to fine-tune the value.

Data Polarity Inverted

Select this checkbox to invert the logic of both data outputs.

Data and Clock Logic Levels

You can quickly set up an output signal that is compatible with your device by selecting a logic family from the **Logic Level** list.

Select the logic family you want to use for the data and clock outputs. When you select a family, the corresponding signal voltage levels and the **Termination** for this family is automatically selected.

NOTE

When you select **Custom**, there are no changes in the expected terminations.

See [“Understanding how the Serial BERT Uses Logic Families and Terminations”](#) on page 74 for additional information.

Data and Clock Terminations

Use the **Data Termination** and **Clock Termination** checkboxes to toggle between true differential DC coupling and center tapped termination. In center tapped mode, you can specify the termination voltage.

The **Data Termination** and **Clock Termination** fields are used to set the termination voltage. When you select a **Data** or **Clock Logic Level**, the terminations are set accordingly. It is recommended that you keep the default values of the terminations.

See [“Understanding how the Serial BERT Uses Logic Families and Terminations”](#) on page 74 for additional information.

0V (Disable)

CAUTION

Before clicking this button, ensure that your device's inputs tolerate ground potential.

Use this button to clamp both the pattern generator's output ports (data and clock) to ground. You can see the status of the outputs in the display area of the pattern generator.

Note that you can also use the buttons below the display to enable or disable this function for data and clock separately.

This function can be useful in case you want to connect or disconnect a device to any of the output ports to prevent any damage.

Output Blanking

In Pattern Mode

When the generator is set up to generate a pattern, use this checkbox to activate the **Aux In** port of the pattern generator. You can then connect

3 Setting up the Pattern Generator

a signal to this port and operate the pattern generator in output blanking mode.

If a logic low signal is supplied to the **Aux In** port, pattern A is sent to the output port. If a logic high is supplied, no data is sent to the output port.

This function is the same as the output blanking function in the **Alternate Pattern Control** dialog box (see “[Aux In](#)” on page 107 for details). However, this function also works with standard patterns.

In Sequence Mode When the generator is set up to generate a sequence, this checkbox is disabled. You can connect a signal to the **Aux In** port of the pattern generator. The reaction on this signal (for example, start sequence execution, or break loop) is defined in the SequenceExpression. For details see “[User-Defined Sequences - Concepts](#)” on page 56.

De-Emphasis

Press the **De-Emphasis** button to control an N4916A De-Emphasis Signal Converter. This opens the **De-Emphasis Connection** dialog.

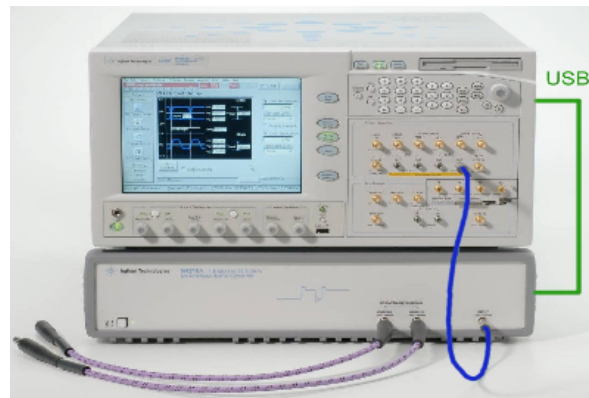

Ensure that the N4916A is switched on and connected via USB cable (rear connection) and signal cable (front connection). Ensure also that all unused outputs of the pattern generator are terminated with 50 Ohm to GND.

Pressing **Connect** activates the N4916A.

NOTE

As long as the N4916A is in **Connected** state, the data signal voltages and termination shown on the screen refer to the Output ports of the N4916A.

To change the de-emphasis amplitude ratio value (for details see “Understanding the N4916A De-Emphasis Signal Converter” on page 77), click inside the text field and either:

- Enter the desired value directly with the numeric keyboard.
- Use the knob by the numeric keyboard to set the value.

You can toggle between dB and percent. Toggling does not change the value.

Pressing **Disconnect** deactivates the N4916A.

Bit Rate

Bit Rate - Concepts

Bit rate is defined as bits per second. The pattern generator's clock rate sets the bit rate and serves as the frequency reference for the clock and data outputs, your device, and the error detector (if it receives its clock from the pattern generator). It can be generated internally or supplied from an external source.

When to Use an External Clock Source?

The Serial BERT's internal clock can be used for most testing purposes. There are some circumstances, however, when an external clock source is required:

- Synchronization with an external clock
The Serial BERT can be connected to an external clock to allow it to run as part of a larger external system.
- Use of a modulated clock
A frequency- or delay-modulated clock can be used to provide a small amount of jitter to the clock signal.
- Use of a precision clock
A precision clock with very low phase noise can be used to enhance the instrument's performance. This is especially interesting for long-term measurements.
- Testing at bit rates < 620 Mb/s

The Serial BERT's clock cannot be used for bit rates below 620 Mbit/s.

Bit Rate Range

The Serial BERT provides bit rates from 150 Mbit/s up to 12.5 Gbit/s, depending on the instrument's options.

However, several specific properties and limitations need to be taken into account when working at low bit rates. The limitations apply to the instrument according to the following hysteresis curve:

- If the bit rate falls below 615 Mbit/s, the limitations apply.
- If the bit rate exceeds 620 Mbit/s, the limitations no longer apply.

The following figure clarifies the behavior in the range between 615 Mbit/s and 620 Mbit/s:

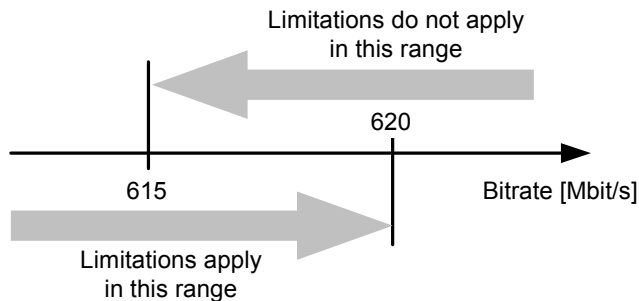

For the pattern generator the following rules apply:

- Below 620 Mbit/s, the pattern generator can only be operated with an external clock source, because the internal clock source can only produce signals higher than 620 Mbit/s.
- The trigger output cannot be set up to trigger on certain pattern positions or pattern sequences. If this option is enabled (for example in the user interface), the trigger is sent once for each pattern, but the bit position cannot be specified.

The option to trigger on the divided clock signal is supported as usual.

- There are restrictions to the available clock to data delay values.

The pattern generator can vary the clock to data delay only within a range of -750 ps to 750 ps (relative to the clock signal). For frequencies above 666 Mbit/s, this range is sufficient to cover the complete clock cycle (= 1 unit interval).

For lower frequencies, the valid data delay range is smaller than the clock cycle. The pattern generator cannot generate signals with a

delay outside this range. Therefore, the data delay cannot be set to all values within the clock cycle.

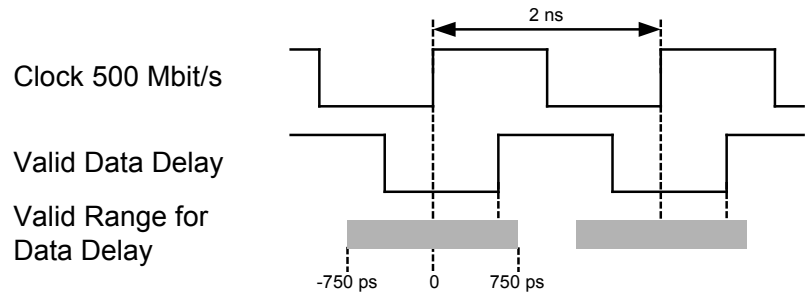

If the clock frequency falls below this threshold, the current data delay value is checked for validity. If the delay does not fall in the valid range, it will be moved into the valid range. All subsequent changes to the data delay will be checked for validity and rejected if invalid.

Spread Spectrum Clocking

A Spread Spectrum Clock (SSC) is widely used for reducing the peak electromagnetic radiation at the nominal clock frequency. With SSC, the clock pulse is modulated with a relatively low-frequency triangle waveform. This broadens the clock signal spectrum and reduces the peak energy.

The Serial BERT has a built-in SSC generator. This is a licensed option. For information on how to enable this feature, see [“Installing Hardware Options - Procedures”](#) on page 406.

The Serial BERT's implementation keeps the specified clock rate as a maximum. It modulates the specified clock rate towards lower frequencies, as illustrated in the following figure.

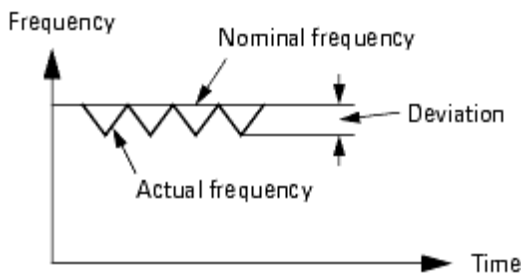

Deviation and modulation frequency can be specified.

NOTE

SSC and sinusoidal jitter are mutually exclusive. For details see [“How the N4903 Generates Jitter”](#) on page 321.

Bit Rate - Procedures

You can use an external clock source or the Serial BERT's internal clock to control the bit rate.

To set the bit rate:

- 1 If the external clock source has a frequency of 10 MHz, connect the clock source to the pattern generator's 10 MHz Ref In port. If the clock has another frequency, connect it to the Clock In port.

- 2 Click the **Bit Rate Setup** icon in the **PG Setup** menu.



- 3 Select the appropriate clock source:

- **Internal Clock Source**

This setting uses the internal clock oscillator.

- **10 MHz Reference Clock**

This locks the clock generator to an external 10 MHz reference.

- **External Clock Source**

This connects the external clock directly to the clock generator.

- 4 If you have chosen an **External Clock Source**, decide between manual or automatic mode.

- In automatic mode, the clock rate of the external source is automatically measured and used. If the source frequency varies, the generated clock varies as well.
- In manual mode, you can measure and set the rate of the external clock source by clicking the respective button. If the source frequency varies, you will be alerted.

- 5 Select a clock rate:

- For **Internal Clock Source**, you can either select a clock rate from the **Presets** list, or enter a clock rate in the **Value and Units** field.
- For **10 MHz Ref Clock Source**, the clock rate connected to the 10 MHz Ref In port must be 10 MHz.

The selected clock rate applies to the pattern generator. This is also the clock rate generated at the pattern generator's Clock Out port.

If the error detector receives its clock from the pattern generator, it runs at the same clock rate.

- 6 If you wish to use the pattern generator's Sub Clock Out port, set the **Subrate Clock Divider** to a suitable value (between 2 and 128).

NOTE

If the Divider Factor n is uneven (e.g. 3), the clock's duty cycle will not be 50%, but the signal will stay high for $(n+1)/2$ and low for $(n-1)/2$. This results in a DCD of 0.5 UI.

Bit Rate - Reference

The **Bit Rate Setup** window contains the following elements:

Clock Source

Clock source can be one of the following:

- **Internal:** The clock generator uses the internal oscillator.
- **10 MHz Ref:** The clock generator uses the 10 MHz Reference that must be connected to the 10 MHz Ref Input.
- **External:** The pattern generator uses the external clock that must be connected to the Clock Input. You can choose between “[Automatic and Manual Mode](#)” on page 91.
- **External PLL:** The pattern generator uses the external clock that must be connected to the Clock Input. This clock is routed internally through a PLL. You can choose between “[Automatic and Manual Mode](#)” on page 91.

Automatic and Manual Mode

The **Manual** checkbox is available if you have chosen an external clock source.



In automatic mode, the external clock frequency is continually measured. When the external clock frequency changes, the bit rate changes as well.

In manual mode, you can enter the expected frequency or press the **Measure & Set** button. **Measure & Set** requires that the external clock generator is connected and active. Its frequency is measured once and determines the bit rate. When the external clock frequency changes, **PG Clock Loss** is signaled.

Value and Units

This text field allows manual entry of the clock rate value. Click inside this text field and use the numerical keypad or front panel knob to enter a clock rate value. Complete the entry with a frequency unit by pressing the **G/n**, **k/m**, **M/μ**, or **X1** front panel key.

Preset List

The **Preset** list contains clock rate values that are commonly used by the pattern generator.

Click a preset to select it for the pattern generator clock rate.

Double-click a preset to modify it.

Add Preset Button

Click this button to open the **Enter Bit Rate** dialog box and add a new clock rate to the preset list. In this dialog box, you can enter a value, unit and text description of the new clock rate.

Delete Preset Button

Select a preset clock rate in the **Preset** list and click this button to remove it from the list. You can only delete presets that are user-defined.

Sub Rate Clock Divider

This setting controls the pattern generator's Sub Clock Out port.

The Sub Clock Out port is differential, always active, and generates a fraction of the current clock. The range of the divider is 2, 3, 4, 5, ... 128.

Spread Spectrum Clock

Spread Spectrum Clocking is a licensed option. This setting controls the pattern generator's spread spectrum (SSC) clocking feature.

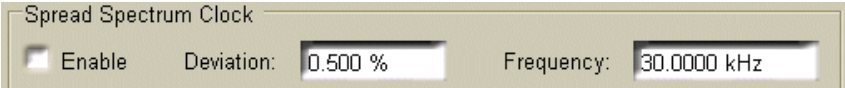

Spread Spectrum Clock

Enable Deviation: 0.500 % Frequency: 30.0000 kHz

When the SSC is enabled, it impacts the Data Out, Clock Out, Sub Clock Out, and Trigger Out ports.

You can set the deviation from the specified clock frequency towards lower frequencies.

For example, if you have set a bit rate of 8.5 GHz, a deviation of 0.5 % would result in a time-linear clock frequency variation between 8.500 GHz and 8.4575 GHz.

The modulation frequency is generally around 30 kHz.

Clock Rate Indicators

The PG (Pattern Generator) and ED (Error Detector) clock rate indicators in the status bar display their current clock rate.

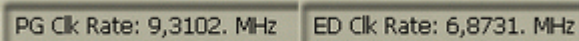

PG Clk Rate: 9,3102. MHz ED Clk Rate: 6,8731. MHz

- The ED clock rate is measured from the incoming clock signal or derived from the data signal.

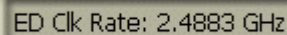

ED Clk Rate: 2.4883 GHz

Trigger Output

Trigger Output - Concepts

The pattern generator's Trigger Out port can be used to send a reference signal (or trigger) to external devices like an oscilloscope or digital communication analyzer.

In pattern mode, the pattern generator sends a trigger signal that is at least 32 bits long. See also [“How the Serial BERT Generates Memory-Based Patterns”](#) on page 31 for details.

In sequence mode, the pattern generator can send a trigger signal whenever a block of the sequence starts or restarts. See also [“Sequence Block Parameters”](#) on page 62 for details.

Several options are available for the trigger signal. As an example, you can send the trigger as a divided clock signal or as an indicator when the data pattern starts.

Trigger Output - Procedures

To set up the pattern generator's Trigger Output port:

- 1 Connect the external instrument to the Trigger Out port.
- 2 Click **Trigger Output** in the PG Setup menu.



- 3 Select the trigger pattern that you want to be generated.

See “[Trigger Output - Reference](#)” on page 94 for descriptions of the available trigger signals.

NOTE

If you have downloaded a user-defined sequence of patterns to the pattern generator, the pattern-related settings are ignored. In this case, you can either set up the Trigger Out port to generate a subrate of the present clock or to signal the beginning of a sequence block (see also “[Sequence Block Parameters](#)” on page 62 for details).

Trigger Output - Reference

You can always generate a divided clock signal at the Trigger Out port. But if you wish to use the Trigger Out port for controlling external equipment, please note that you can also generate a divided clock signal at the pattern generator's Sub Clock Out port.

The alternate trigger signals refer to patterns and are not generated in sequence mode.

To support the generation of a trigger spike at the beginning of a sequence block, the Trigger Output can be put into **Sequence** mode.

Clock Divided by n

Select this option to send a trigger signal from the Trigger Out port at every *n*th clock pulse. Note that the trigger signal itself consists of $n/2$ bits high followed by $n/2$ bits low. For example, **Clock divided by 8** works as shown below.

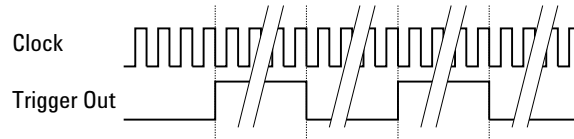

Alternate Pattern Trigger Level

NOTE

This option applies for alternating patterns only.

Select this option to set the trigger level high whenever alternate pattern B is sent.

The trigger output for 1024-bit patterns looks as follows:

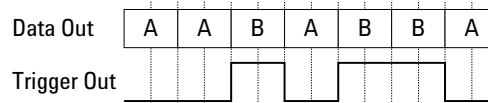

NOTE

This pattern must be at least 1024 bits long.

Alternate Pattern Trigger Pulse

Select this option to send a trigger pulse whenever the pattern being sent changes (A to B or vice versa). For patterns with a length divisible by 512, there is one trigger pulse sent for every pattern repetition.

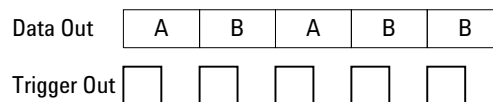

If the length of the pattern is not divisible by 512, a trigger is sent whenever the pattern reaches a 512-bit RAM boundary.

Sequence Trigger

This checkbox becomes available after a user-defined sequence has been downloaded to the pattern generator.

Click this checkbox to switch the Trigger Out port from **Clock divided by n** to **Sequence** mode.

In **Sequence** mode, the Trigger Out can generate a spike whenever the execution of a block starts or restarts. Whether that happens for a

particular block or not is defined for each block individually in the SequenceExpression. See also “Sequence Block Parameters” on page 62.

Pattern Trigger Position

NOTE

This option is not available for alternate patterns.

Select this option to send a trigger signal that is synchronized to a certain position in the pattern. Depending on the type of pattern currently loaded in the pattern generator, you have to specify the trigger position either according to **Bit Position** or **N-bit Trigger Pattern**:

- **Bit Position**

If a memory-based pattern is loaded in the pattern generator, you have to specify the bit in the pattern that sends the trigger. The bit position can be in the range 0 ... Pattern Length - 1.

For pattern lengths that are divisible by 512 (such as 2^n PRBS patterns), the trigger repetition rate is one pulse per pattern repetition.

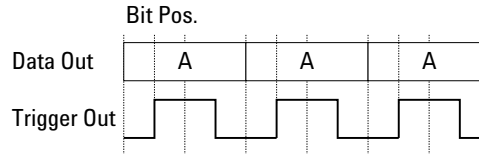

For pattern lengths that are *not* divisible by 512 (such as some memory-based patterns), a trigger signal is sent once at the corresponding bit when the pattern reaches the 512-bit boundary. If, for example, the pattern is 384 bits long, a trigger signal is sent every 4th pattern repetition.

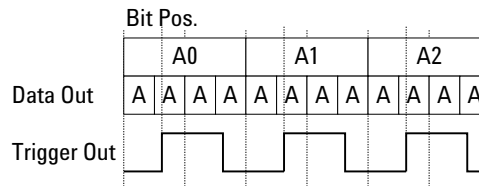

If the entered number is greater than the pattern length, the entry is adjusted to the pattern length - 1. If you load a pattern that is shorter than the entry in this field, the trigger will be set to the next to the last bit in the pattern.

- **N-bit Trigger Pattern**

This option is used for hardware-generated PRBS patterns. You can specify a pattern with n bit length. A trigger pulse is sent when this pattern is found in the PRBS. The trigger repetition rate is one pulse per 512 pattern repetitions.

Example:

Pattern length: 2^7-1 (127) bits

N-bit pattern: 1110001

Data Out 10111000100 10111000100

Trigger Out 

- **Shift Trigger Position**

Clicking the left and right buttons will move the bit trigger position back and forward by one bit.

Delay Control Input

Delay Control Input - Concepts

The Serial BERT features a wide bandwidth voltage controlled delay line in its pattern generator data path, which can be used to delay the data relative to the clock. The delay is controlled by an external signal connected to the Delay Ctrl In connector on the pattern generator front panel.

The delay control input is intended primarily for jitter tolerance testing, where a data signal with a defined amount of jitter is needed. Random jitter (RJ) can be created by applying high bandwidth white Gaussian noise, periodic deterministic jitter (DJ) with sinusoidal (SJ) or rectangular/triangle signals (PJ).

The delay control input is most useful for the generation of high frequency, low amplitude jitter. Higher amounts of jitter at lower frequencies (wander) can be generated by supplying an FM modulated clock to the pattern generator's clock input (Clk In) in external clock mode.

3 Setting up the Pattern Generator

NOTE

At an Serial BERT on which the calibrated and integrated jitter injection option J10 is installed, the delay control input is rarely used as explained above. The option J10 includes all the jitter sources required for jitter tolerance tests. For details see “[Jitter Tolerance Tests - Concepts](#)” on page 315.

The delay control input is equipped with overvoltage protection. If the applied voltage is too high, the input is automatically disabled, and the following dialog appears:



You can enable the input after reducing the voltage to safe level.

Delay Control Input - Procedures

NOTE

The following procedure does not apply to an Serial BERT on which the calibrated and integrated jitter injection option J10 is installed. For such instruments refer to “[Jitter Setup - Procedures](#)” on page 326.

To set up a jitter tolerance test on an instrument without option J10:

- 1 Press **PG Output Setup** in the **PG Setup** menu.
- 2 Disable the Delay Control In port by clearing the **Delay Control Input** checkbox.
- 3 Connect the device that supplies the jitter signal to the Delay Control In port.
- 4 Enable the port again by selecting the **Delay Control Input** checkbox.

TIP

While monitoring the BER you can use this checkbox to switch jitter on and off and view the effect on the BER.

Delay Control Input - Reference

This checkbox in the **PG Output Setup** window is used to disable or enable the Delay Control In port, where you can supply an external signal to add jitter to the output signal.

NOTE

This checkbox is not available on instruments on which the calibrated and integrated jitter injection option J10 is installed. On such instruments, the Delay Control In port is enabled or disabled from the **Jitter Setup** window.

Error Addition/Insertion

Error Addition/Insertion - Concepts

To test error correction algorithms, alarms and other functions that are imbedded in the data pattern, you can insert logic errors (flipped bits) into the pattern.

The instrument provides several options (in the pattern generator's **Error Add** dialog box) for inserting error bits manually or automatically.

Error Addition/Insertion - Procedures

You have the following options for inserting errors into the output data stream:

Manually Inserting Errors

To manually insert a single error into the output stream:

- 1 Click the **Error Add** button at the top of the screen to insert one single bit error in the output stream.

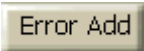
 A rectangular button with a light beige background and a thin black border. The text "Error Add" is centered on the button in a dark grey font.

This button is active unless you define a fixed internal error rate. The maximum number of errors that this function supports, is one error per 128-bit block.

3 Setting up the Pattern Generator

- 2 If you want to disable all other error insertion functions, so that **only** manual error insertion is possible, click the **Error Add Setup** icon in the **PG Setup** menu to open the **Error Add Setup** dialog box.



- 3 Select **Off** and click **OK** to close the dialog box.

Using an External Signal for Inserting Errors

To configure the Serial BERT to insert a single error into the output stream according to an external signal:

- 1 Connect an external instrument to the Error Add port.
The signals received at this port must be TTL-compatible.
- 2 Click the **Error Add Setup** icon in the **PG Setup** menu.



- 3 Select **External (Error Add)** and click **OK** to close the dialog box.

Now, upon a rising edge of the signal at the Error Add port, an error will be generated in the output stream by flipping a single bit within a bit block of 128 bits (resulting in a maximum BER of 1/128 or 10^{-2}).

TIP

You can use an external signal to set up a bit error rate to fit your needs. The frequency of the external signal can be calculated by multiplying the desired bit error rate by the clock frequency.

If, for example, you want a bit error rate of 3×10^{-7} and you are running a test at 12.5 G b/s, the frequency of the external signal is:

$$3 \times 10^{-7} \times 12.5 \times 10^9 = 3750 \text{ Hz}$$

Using the Serial BERT to Insert Errors

To configure the Serial BERT to automatically insert errors in the output stream to achieve a desired bit error rate:

- 1 Click the **Error Add Setup** icon in the **PG Setup** menu.



- 2 Select **Internal**.
- 3 Use one of the following options to define the **Error Insertion Rate**:

- **Error Rate** allows you to select a BER from a list.
- **Bits between Errors** allows you to specify how many regular (correct) bits are sent without errors before inserting the next error.

4 Click **OK** to close the dialog box.

TIP

To find out how your DUT reacts on very small bit error rates, set up the pattern generator to enter errors once every 10^{-12} bits and run a longer accumulative test. You can then find the DUT's true error rate by calculating the difference between the bit error rate set up in the pattern generator and the accumulated bit error rate found by the error detector.

NOTE

If you set up too high an error rate, the error detector will not be able to synchronize to the incoming pattern. When setting up an error rate, always make sure that the synchronization threshold is higher than the bit error rate.

Error Addition/Insertion - Reference

The following functions are available to insert errors in the bit stream:

Error Add Button

The **Error Add** button in the top right corner is used to insert a single bit error in the data stream.



This button is always active, even if other error insertion mechanisms are running. The maximum number of errors that this function supports is one error per 128-bit block.

Error Add Setup Dialog Box

The **Error Add Setup** dialog box provides the following configuration options:

External (Error Add)

With this option selected, when a rising edge is detected at the Error Add port, an error will be generated in the output stream by flipping a single bit within a bit block of 128 bits.

The signals received at this port must be TTL-compatible.

Internal

Select this option to use internal error insertion functions:

- **Error Rate**

Allows to select from a preset bit error ratio from **1.000E-02** to **1.000E-09**. Errors will be added to the output pattern to produce this error ratio.

- **Bits Between Errors**

Allows you to enter the number of valid bits between two errors. This is the inverse of the bit error ratio.

Off

Select this option turn off all internal add rates and external error inputs. This allows you to manually add single errors by pressing **Error Add** on the main display. This flips a single bit in the output stream.

Pattern Alternation

Pattern Alternation - Concepts

This section explains the basic purpose of alternating patterns. Two alternate patterns can be stored in one pattern file.

Note that you can also generate a sequence of up to four alternating patterns (see “[User-Defined Sequences - Concepts](#)” on page 56).

Standard and Alternating Patterns

With the Serial BERT, you have full control on the data stream that is sent by the pattern generator to your device under test. You can use standard patterns to specify a test data pattern that is sent to your DUT repeatedly.

Or, you can use alternating patterns to specify two patterns that are sent to the DUT alternately. To implement alternating patterns, the instrument's user pattern memory is split into two portions; one for pattern A and one for pattern B.

The differences between these patterns are:

- *Standard patterns* consist of one single pattern that is repeatedly sent. Any arbitrary pattern up to 32Mbit length can be set up. However, there are no further configuration possibilities. This pattern is sent as long as the output port is enabled.
See “[Setting up Patterns - Concepts](#)” on page 23 for more details.
- *Alternating patterns* consist of two patterns, one of which is pattern A (the A half), the other is pattern B (the B half). Both patterns are of equal length, each up to 16Mbit.

The **Alternate Pattern Control** dialog box lets you control when which pattern is sent. See the online Help for details.

When to Use Alternating Patterns

Alternating patterns can be used:

- To systematically insert errors in the bit stream at particular positions.

The error detector expects pattern A only. If you set up pattern B so that there are only minor differences, when you run the test, the error detector will detect the changed bits as errors.

- To see how long it takes your DUT to settle.

You can set up an easy-to-process output stream as the standard pattern, and a difficult output stream as the alternate pattern (for example, all 0s for the standard pattern, and alternating 1s and 0s as the alternate pattern). You can then track how long it takes for your DUT to recover after the alternate pattern has been sent.

Pattern Alternation - Procedures

The **Alternate Pattern Control** dialog box controls how the output stream switches between the standard pattern and the alternate pattern.

You have the following possibilities for setting up alternating patterns:

Setting Up a Periodical Output

To configure the pattern generator to generate periodical data output:

- 1 Press the **Alt. Pattern and Aux In** icon in the **PG Setup** menu to open the **Alternate Pattern Control** dialog box.



- 2 Select one of the following options:
 - **Continuous A**
Only pattern A is output repeatedly.
 - **Continuous B**
Only pattern B is output repeatedly.
 - **Alternate AB**
The output stream switches between pattern A and pattern B.
 - **Single Shot B**
With this option selected, the **Insert B** button is enabled.
- 3 Select **OK** when your selection is complete.

Manually Inserting Pattern B into the Output Stream

You can insert a single shot of pattern B into the continuous stream of pattern A:

- 1 Press the **Alt. Pattern and Aux In** icon in the **PG Setup** menu to open the **Alternate Pattern Control** dialog box.



- 2 Select **Single Shot B** and click **OK** to close the dialog box.
- 3 During the test run, press the **Insert B** button on the screen.



This inserts a single occurrence of pattern B into the output stream of pattern A.

Inserting Pattern B via External Signal

You can configure the Serial BERT to insert pattern B into the continuous output stream of pattern A according to an external signal:

- 1 Connect an external instrument to the Aux In port.

The signals received at this port must be TTL-compatible. The granularity for the insertion of pattern B via external signal is 512 bits.

- 2 Press the **Alt. Pattern and Aux In** icon in the **PG Setup** menu to open the **Alternate Pattern Control** dialog box.



- 3 In the **Aux In** section, define whether the Serial BERT should insert pattern B in **Level Sensitive** or **Edge Sensitive** mode.

See “[Aux In](#)” on page 107 for more information on the different available modes.

- 4 Click **OK** to close the dialog box.

Suppressing the Outputs via External Signal

You can configure the Serial BERT to suppress the output according to an external signal:

- 1 Connect an external instrument to the Aux In port.

The signals received at this port must be TTL-compatible. The granularity for the insertion of pattern B via external signal is 512 bits.

- 2 Press the **Alt. Pattern and Aux In** icon in the **PG Setup** menu to open the **Alternate Pattern Control** dialog box.



- 3 In the **Aux In** section, select **Output Blanking**.

See “[Aux In](#)” on page 107 for more information on the different available modes.

- 4 Click **OK** to close the dialog box.

Pattern Alternation - Reference

The Serial BERT offers the following options for alternating between pattern A and pattern B:

NOTE

These functions are only available if **Alternate Pattern** is selected in the **Pattern Properties** dialog box.

Continuous A

Select this option to send out only pattern A repeatedly.

	A0				A1				A2			
Data Out	A	A	A	A	A	A	A	A	A	A	A	A

Continuous B

Select this option to send out only pattern B repeatedly.

	B0				B1				B2			
Data Out	B	B	B	B	B	B	B	B	B	B	B	B

Alternate AB

Select this option to alternately send out patterns A and B (A, B, A, B...).

	A0				B0				A0				B0			
Data Out	A	A	A	A	B	B	B	B	A	A	A	A	B	B	B	B

Single Shot B

Select this option in the **Alternate Pattern Control** dialog box to enable the **Insert B** button on the main display.



When you press the **Insert B** button, pattern B is inserted into the continuous output of pattern A.

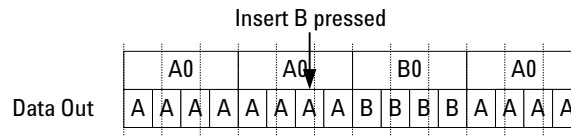

Aux In

In this section you can enable the Aux In port to control the output pattern. Aux In can receive signals that control alternate patterns or blank the output.

The signals received at this port must be TTL-compatible. The granularity for signals at this port is 512 bits.

The following options are available for **Aux In**:

- **Disable**

With this option selected, the signal at the Aux In port will be ignored.

- **Level Sensitive**

- If **Aux In** is logic high, pattern B is sent.
- If **Aux In** is logic low, pattern A is sent.

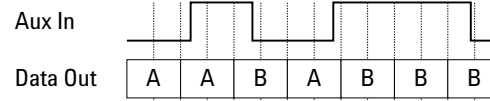

- **Edge Sensitive**

Pattern A is sent out until a rising edge at Aux In is detected. Then, at the next complete repetition of pattern A, a single occurrence of pattern B is inserted into the output.

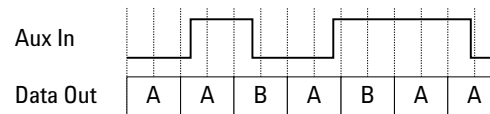

- **Output Blanking**

Pattern A is sent when the signal at Aux In is low. Pattern B is not sent in this mode.

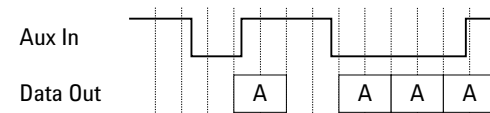

If **Aux In** is pulled to logic high and a standard pattern is selected, no output pattern will be sent.

3 Setting up the Pattern Generator

NOTE

Due to the pattern generator behavior, the patterns may be repeated up to 512 times before alternating. See [“How the Serial BERT Generates Memory-Based Patterns”](#) on page 31 for details.

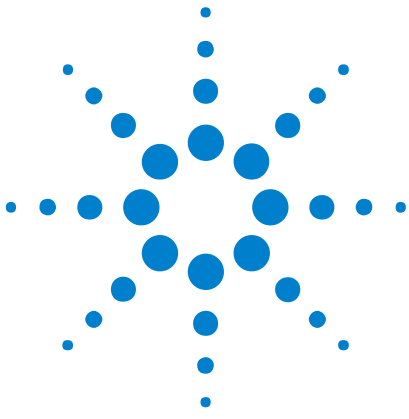

4 Setting up the Error Detector

Setting up the Error Detector - Concepts

The error detector analyzes an incoming bit stream, compares it to the expected pattern, and locates any inconsistencies. The error detector requires the following settings to work correctly:

- The expected pattern
The error detector needs to "know" which data to expect so that it can detect bit errors.
- Correct input and output terminations to the DUT
This ensures that your DUT cannot be damaged due to incorrect terminations.
- Correct clock frequency
Required to recognize the bit rate in the data stream.
- Appropriate sampling point
The sampling point defines where the error detector tries to differentiate between 0s and 1s in the data stream. This is necessary so that the error detector recognizes the data bits correctly.
- Synchronization to the incoming pattern
The expected pattern must be synchronized to the incoming pattern so that the error detector can find any discrepancies.

The error detector provides the following functions to enable you to perform tests:

- Automatic pattern synchronization
The error detector shifts the incoming data stream bitwise to match it to the expected data pattern. A correct BER can only be measured with matching patterns.
- Error accumulation



4 Setting up the Error Detector

You can specify whether a test runs for a specified time or until a specific number of errors has occurred. This lets you carry out longer tests while logging the results to a file.

- BER location mode

You can specify whether all errors are counted or only the errors that occurred on a particular bit position or range of positions.

- Audio warnings

You can set up the audio warnings so that the instrument beeps when a certain BER is exceeded.

- Trigger output for external measurement instruments

This allows you to connect other devices for further error analysis.

NOTE

When the Bit Recovery Mode (BRM) option is installed, the error detector is able to detect bit errors without expecting any particular pattern. This feature allows you to investigate the behavior of the DUT when the sampling point is moved.

Inputs and Outputs

Inputs and Outputs - Concepts

The error detector (ED) provides input and output ports for running tests and for connecting external equipment.

The error detector has the following inputs and outputs:

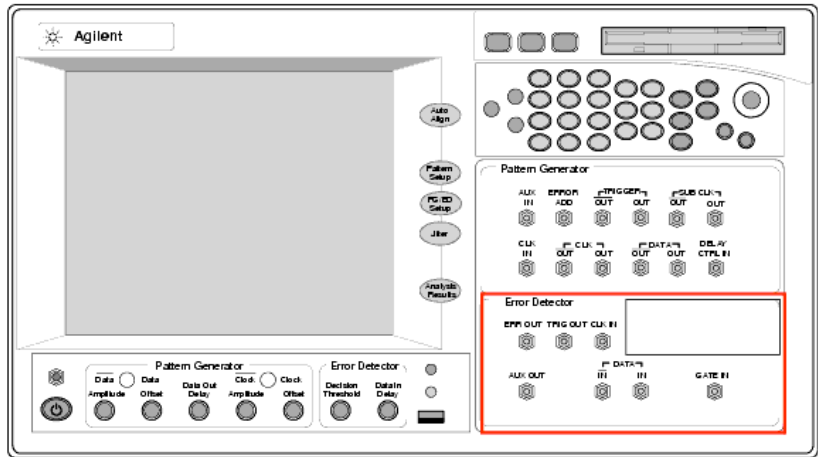

Understanding Error Detector Input Ports

The error detector has the following input ports:

- Clock In

This port needs to be connected to a clock signal unless you use the error detector in Clock Data Recovery (CDR) mode, where it derives the clock frequency from the data port. See [“Clock Setup - Concepts” on page 116](#) for more details.

- Data In and $\overline{\text{Data In}}$

This port is connected to the data signal and the inverted data signal.

- Gate In

This port has two different functions.

- In normal mode it can be used to enable and disable the error counter. Errors are only counted when this signal is low.

The error counter can only count errors in 128-bit data blocks. Thus, the signal at the Gate In port must be low for at least 128 bits to enable the counter. The following figure illustrates the effect of error gating. Errors are only counted in the gray blocks.

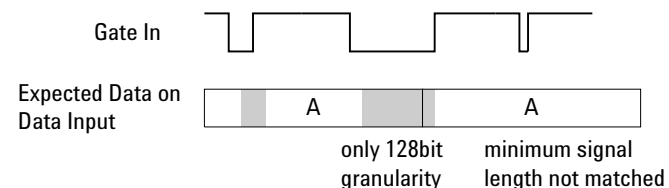

- The burst sync mode is a special operating mode for measuring data in bursts of bits, rather than one continuous stream of bits.

4 Setting up the Error Detector

In this case, the signal at the Gate In port controls the timing of synchronization and error counting for each burst.

Understanding Error Detector Output Ports

The error detector provides several output ports that are used to connect it to other devices for further error analysis:

- **Trigger Out**

Use this port to send a trigger signal to another connected device, such as an oscilloscope.

- **Error Out**

This signal can be used to trigger an external instrument to help in error analysis. When any number of errors are located within a 128-bit data block, a single trigger pulse is sent. If continuous errors are detected, the error out signal would be a clock signal.

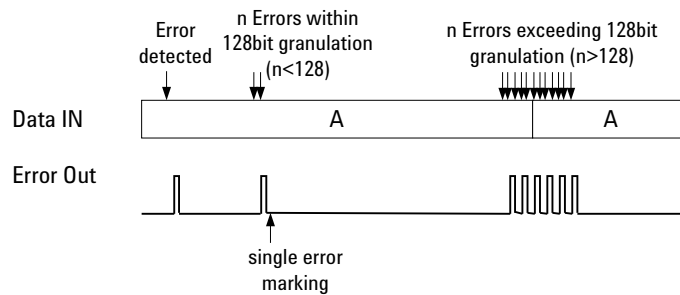

- **Aux Out**

This port can be used to output the clock signal or the data signal to another connected device.

The following figure shows how the clock signal is directed to Aux Out in Clock mode:

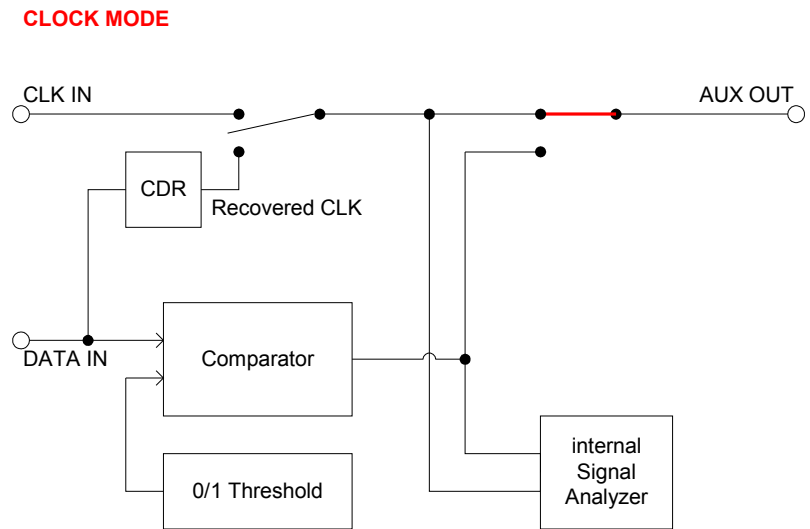

Data In Port Termination

To ensure a valid setup and to protect the devices from damage, proper termination must be specified for both Data In connections. You can specify the termination by entering the termination voltage in the respective field.

CAUTION

Selecting the wrong termination may damage your device.

Why Can Wrong Terminations Damage Your Device?

Choosing wrong terminations may cause your device to output voltage levels that are not as expected. It may also cause excessive current or current flow in the wrong direction, which can damage your device.

NOTE

The clock termination is set to 50 Ohm, AC-coupled, and cannot be changed.

Inputs and Outputs - Procedures

To select the termination for the error detector:

NOTE

Prerequisite: You must know the termination voltage of the data signal that your DUT sends to the error detector.

- 1 In the **ED Setup** menu, press **Sampling Point Setup** to access the **Sampling Point Setup** window.
- 2 Click the **Edit** button. This opens the **ED Input Setup** dialog.

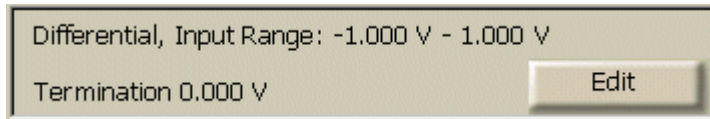

- 3 In the **Termination** field, enter the termination voltage that is appropriate for the incoming data signal.

You can use the front panel knob or the numeric keypad to enter the value.

CAUTION

Selecting the wrong termination may damage your device.

- 4 Select the **Data Inverted** checkbox if your device inverts data.

You can now physically connect the DUT to the error detector.

Data Input Setup - Reference

The **ED Input Setup** dialog is accessed from the **Sampling Point Setup** window. It is used to set up the error detector's data input port:

Input

The selection in this list defines how the signals arriving at the Data In and $\overline{\text{Data In}}$ connectors are interpreted. The following options are available:

- **Differential**

If differential mode is selected, both input ports need to receive a signal. The actual data signal is measured as the voltage difference between the two incoming signals.

- **Normal**

In normal mode, only the Data In port receives the data signal, the $\overline{\text{Data In}}$ port is inactive.

- **Complement**

In complement mode, only the $\overline{\text{Data In}}$ port receives the data signal, the Data In port is inactive.

Data Inverted

Activate this checkbox to invert the polarity of the error detector reference pattern. This function is required if your device inverts data.

Threshold

Only available, if the input is set to normal or complement mode.

Choices are:

- **Averaging:** The 0/1 threshold voltage is derived from the input signal via a low-pass filter. This will work fine for most applications.
- **Manual input:** Enter a value for applications that do not provide a continuous data stream at the input (for example, any application using bursts), because the averaged 0/1 threshold voltage will drift from the correct level when there is no input. The manually set threshold voltage must of course be within the input range.

Termination

In this field, enter the termination voltage that is appropriate for the incoming data signal. This selection should be made before the device is connected to the analyzer.

If the input is set to differential mode, a termination voltage can only be set for a device that is DC-connected.

CAUTION

Selecting the wrong terminations may damage your device.

The Data In port is connected to a 50 Ohm load impedance (or termination) within the error detector. Data termination refers to the voltage level at the end of this load. The logic output from a device

4 Setting up the Error Detector

requires any connected equipment, including the error detector, to have a specific termination voltage.

Input Range

Before you can synchronize the error detector to the incoming data stream, you need to define the voltage range within which the eye is located.

Both the high and low level of the data signal must be within this range to find the eye.

NOTE

The input voltage range is 2V. When you modify either the high or low voltage, the other voltage is automatically adjusted.

NOTE

See “[Sampling Point Setup - Reference](#)” on page 131 for a complete description of all parameters of the **Sampling Point Setup** window.

Clock Setup

Clock Setup - Concepts

To measure the Bit Error Rate with the error detector, the bit rate of the data stream must be known. Depending on the options the instrument is delivered with, you could use either an external clock source for the error detector (for example, the clock from the pattern generator), or extract the clock signal from the incoming data (CDR mode).

CDR mode does not work for all kinds of data patterns. For example, if the device under test sends only blocks of ones and zeros, there are no transitions in the data stream and the Serial BERT cannot recover the clock.

Also, if you are testing bursts, there are some special considerations for setting up CDR. See the following sections for details.

How does Clock Data Recovery Work?

In CDR mode, the CDR has to recover the clock from the incoming data. To do this, the hardware has to decide whether the voltage at the input connector is a logical '1' or '0' and then recover the clock from the detected transitions.

Clock Data Recovery (CDR) is a special kind of Phase Locked Loop (PLL), which recovers clock signal from of a data stream. It is a regulatory loop, which synchronizes the local oscillator with an external reference, in this case the incoming data stream.

Phase Locked Loop

A PLL has three parts: a phase detector, a loop filter, and a voltage controlled oscillator (VCO). The phase detector has two inputs, and one output, which is proportional to the phase difference of the inputs. The loop filter is a low pass filter which attenuates the higher frequencies from the output of the phase detector. The VCO is an adjustable oscillator which changes the output frequency depending on its input voltage. The diagram below shows a simple PLL.

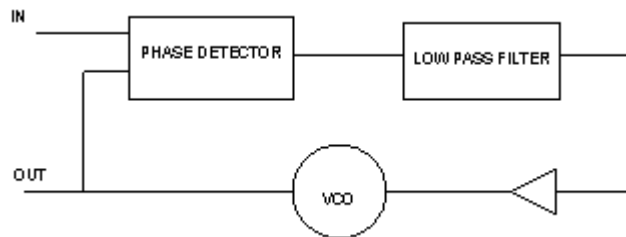

One of the most important characteristics of a PLL is its loop transfer function. The loop bandwidth is defined as the integrated magnitude of the PLL's frequency transfer function over the entire frequency spectrum. The loop bandwidth describes how the regulatory loop tracks the VCO to a sine wave FM modulated input signal. Above the bandwidth the loop cannot track such a modulation completely, and thus, the response to the modulation is attenuated.

The other loop parameter is peaking. This describes how much a modulation is exaggerated (mostly close to the loop bandwidth).

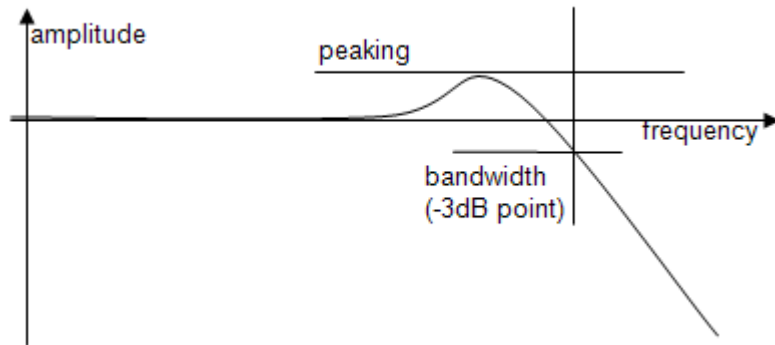
**NOTE**

The “frequency” is the modulation frequency, and “amplitude” is the tracking of the PLL.

Data rate and loop parameters

The data stream contains multiple frequencies, and the CDR needs to know the expected data rate. The user entered information is necessary to lock the CDR, and to detect a loss in lock condition. The entered frequency should be accurate, and better than 100 ppm.

Option CTR / Upgrade UTR offers a tunable CDR, which has additional input parameters: loop bandwidth, transition density, peaking, and SSC deviation.

Loop bandwidth is the input parameter to set the characteristics of the loop.

Additionally, the Peaking can be chosen from a drop down list.

Transition density affects the loop parameters, and it must be either entered, or measured. Some standards define a loop bandwidth for a specific transition density.

The SSC deviation parameter widens the window for loss in lock detection, and detunes the center of detection, because SSC is generally asymmetric (down-spread).

NOTE

CDR is not available together with Bit Recovery Mode (BRM) over a data rate of 11.5 GHz.

Threshold

The regular threshold voltage is not only used to determine the optimum sampling for the data, but also to perform measurements such as eye diagram or output level measurements, it is not possible to use it for the clock recovery.

For this reason, the clock recovery circuitry has its own comparator for the incoming data. This comparator also needs to know the threshold voltage (0/1 decision threshold).

The threshold voltage can be derived from the input signal via a low-pass filter. This will work fine for most applications. But applications that do not provide a continuous data stream at the input (for example, any application using bursts) cannot use this low-pass filter, because the threshold voltage will drift from the correct level when there is no input. In such cases, the threshold can be specified manually. It is then no longer derived from the input signal (see the following figure). The manually set threshold voltage must of course be within the input range.

The difference between the data path and the CDR path is that the comparator of the CDR is always single-ended. Thus, this comparator always needs a threshold voltage that lies between the high and low levels of the incoming signal.

The differential threshold of the data path comparator has no relation to the single-ended threshold of the CDR path comparator. This means that in differential mode, the two thresholds will be different and in single-ended mode (either normal and complement) they will/can be equal (except during measurements).

The following figure shows a simplified block diagram. It does not reflect the different input modes (especially the differential case), but it matches both single-ended cases.

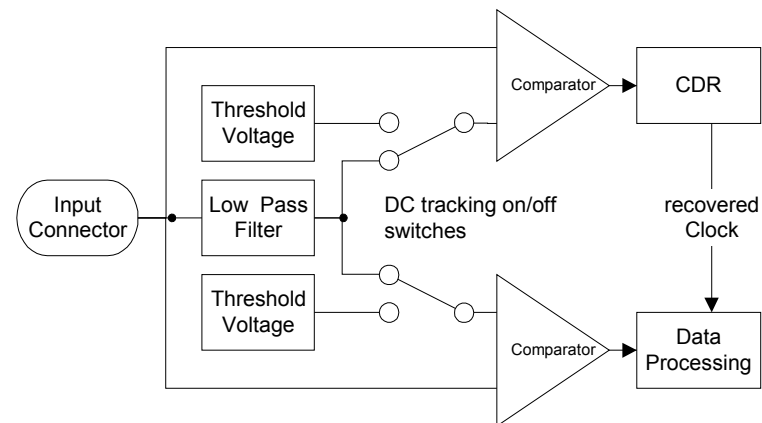

Bit Rate Range

The Serial BERT provides bit rates from 150Mbit/s up to 12.5 Gbit/s, depending on the instrument's options.

However, several specific properties and limitations need to be taken into account when working at low bit rates. The limitations apply to the instrument according to the following hysteresis curve:

4 Setting up the Error Detector

- If the bit rate falls below 615 Mbit/s, the limitations apply.
- If the bit rate exceeds 620 Mbit/s, the limitations no longer apply.

The following figure clarifies the behavior in the range between 615Mbit/s and 620 Mbit/s:

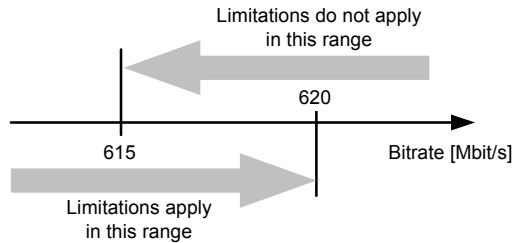

For the error detector the following rules apply:

- For low frequencies, you cannot use the automatic data alignment functions (**Auto Align** and **Data Center**). Instead you need to align the error detector manually. For instructions, please refer to the Online Help, go to the **Error Detector Setup** section, select **Sampling Point Setup**, and switch to the **Procedures** information.
- There are restrictions to the available sampling point delay values.

The error detector can vary the sampling point delay only within a range of 0ps to 1.6129ns (relative to the clock signal). For frequencies above 620 Mbit/s, this range is sufficient to cover the complete clock cycle (= 1 unit interval).

For lower frequencies, the maximum sampling point delay is smaller than the clock cycle. Therefore, the sampling point cannot be set everywhere within the clock cycle.

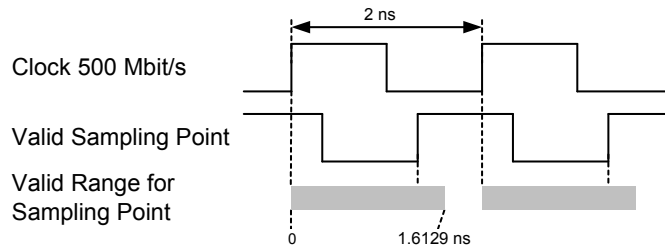

If the clock frequency falls below this threshold, the current sampling point delay value is checked for validity. If the delay does not fall in the valid range, it will then be moved into the valid range. All subsequent changes to the sampling point delay will be checked for validity and rejected if invalid.

If you cannot find the optimum sampling point in the valid range of sampling points, you can switch from the rising to the falling clock edge. For this purpose activate the **Clock Falling Edge** checkbox on the **Sampling Point Setup** screen of the error detector setup.

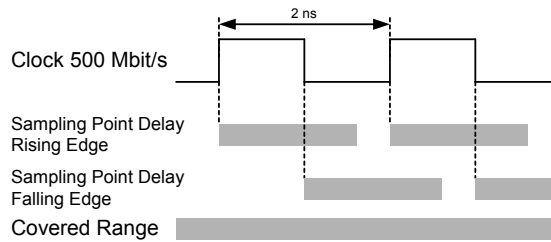

With this method you can still place the sampling point anywhere in the clock cycle to find the optimum sampling point, even at low frequencies.

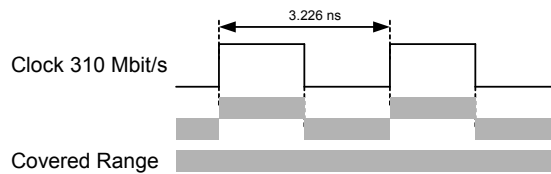

However, if the bit rate falls below appr. 310 Mbit/s, even with this method gaps occur in the range of possible sampling points.

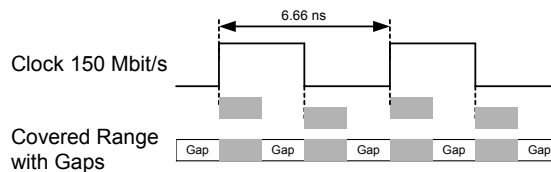

As a result, you might not be able to find the optimum sampling point, if it falls in one of the gaps.

Clock Setup - Procedures

To set the clock rate:

- 1 Press **Clock Setup** in the **ED Setup** menu.
- 2 Specify whether you are using an **External Clock Source** or **Clock Data Recovery (CDR)**.
- 3 If you are using CDR, you need to approximately specify the clock rate in the **Clock Rate** field (with an accuracy of 0.01%).
- 4 If you are measuring bursts, deactivate **Auto Threshold** and set the threshold manually. You can also press the **Measure** button to measure the current DC level at the CDR input and set the measured value as CDR threshold.

- 5 Clock rates that are frequently used can be saved as presets in the **Preset** list.

The **Preset** list always displays the presets within a certain frequency range. Use the **CDR Range** selection list to display the presets of another range.

To select a clock rate from the **Preset** list, click on it. The clock rate appears in the **Clock Rate** field.

- 6 Specify the Loop Bandwidth within the range of 100 KHz to 12MHz. Press the **Advanced** button to select **Peaking and Fine Adjust**. When using a **Preset**, this is only required when you want to change these values.
- 7 **Enable** Spread Spectrum; and adjust the deviation (%) as required.
- 8 Either enter the **transition density** manually, or run a measurement to update this value.

Clock Setup - Reference

The **Clock Setup** window contains the following elements:

Error Detector Bit Rate

The bit rate of the data reaching the error detector is displayed in the lower right corner of the user interface.

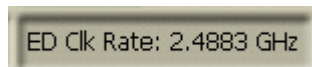

ED Clk Rate: 2.4883 GHz

The bit rate of the error detector is set by the clock signal received by the error detector. If the output bit rate of your device is not equal to its input bit rate, the pattern generator and error detector will be operating at different frequencies.

Clock Mode

The error detector supports two different clock modes:

- **External Clock Source**

If this mode is selected, the Serial BERT uses the clock signal that is connected to the Clock In port.

- **Clock Data Recovery**

If this mode is selected, the Serial BERT derives the exact bit rate from the incoming data stream. To make this function work, the

approximate clock rate must be specified in the **Clock Rate** field (with an accuracy of 0.01%).

Clock Rate

This field is used to specify the approximate clock rate for CDR mode. Serial BERT needs this value to be about 0.01% accurate to find the actual bit rate in the data stream.

Use the numeric keypad to enter the value followed by the unit that you can select with the **G/n**, **M/ μ** , **k/m**, and **X1** keys on the front panel.

Alternatively, you can select a value from the **Preset** list.

CDR Range

Use this field to select the range of clock rate values that is displayed in the **Preset** list.

This field only applies to units with serial No DE45Axxxx. N4903A units with serial number DE46Bxxxxx and/or CTR/UTR option have one continuous range, and it is not necessary to select the range. The number of ranges, and the whole frequency range depend on the instrument and its options. The available range is displayed here.

Preset List

The **Preset** list contains clock rate values that are commonly used by the error detector. It always displays the values that are in the range selected with **CDR Range**.

With the options CTR upgrade and UTR these presets also modify the loop parameters of the tunable CDR according to the selected standard. The factory presets consider the parameters as given in the selected standard.

Click a preset to select it for the error detector clock rate.

Double-click a preset to modify it.

Add Preset

Use the **Add Preset** button to add a new preset to the **Preset** list. You can then enter a value, a unit, and a short description for this new preset.

Delete Preset

Use the **Delete Preset** button to delete the currently selected preset from the list.

Transition Density

The **transition** density is available only with option CTR / upgrade UTR. Number of transitions in the incoming data divided by the total number of bits transmitted. In this field enter the transition density in (%). Click 'measure' to measure and update the transition density.

This parameter affects the loop bandwidth, and thus must be either entered correctly or measured. Some standards specify the loop bandwidth for a given transition density. In such a case enter the value given in the specification, so that the CDR behaves according to the standard. If a standard from the preset list is selected, this field is preset.

Loop Bandwidth

The loop bandwidth is only available with option CTR / upgrade UTR. This is the range of the CDR loop bandwidth. In this field the user should enter the loop bandwidth value; the range is within 100 KHz to 12MHz. If a standard from the preset list is selected, this field is preset.

When the BERT error detector is used to characterize a data stream instead of a receiver, the loop parameters should be set according to the used standard.

If the CDR is used to recover the bit stream from a receiver to be characterized due to a lack of a clock output, choose the loop bandwidth significantly higher than the receiver's bandwidth. To characterize a DUT's CDR it is the best practice to use its recovered clock output instead of the BERT's built in CDR. Choose a low loop bandwidth to measure the jitter on an incoming data stream as the CDR will track the incoming jitter up to the loop bandwidth and thus make it invisible to the error detector.

Advanced

Advanced is available only with option CTR / upgrade UTR.



Clicking on this opens the advanced CDR setup page.

Advanced CDR setup

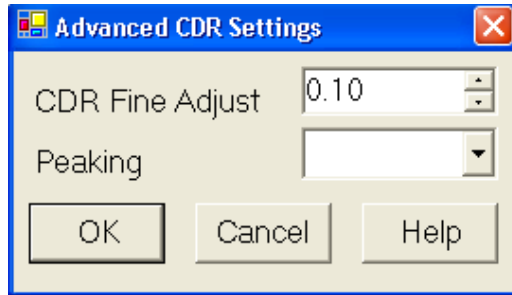

Fine Adjust

Fine Adjust allows you to tweak the response of the CDR according to transition density changes. This control can be used to reduce jitter in pattern with high changes in transition density.

Peaking

The drop down list provides a maximum of three peaking values. If a standard from the preset list is selected, this field is preset. A low value reduces the peaking near the loop bandwidth while, a higher value improves the SSC response.

Auto Threshold

If the **Auto Threshold** option is selected, the Serial BERT continuously analyzes the incoming data stream to detect the voltage level that is optimal for the derivation of the clock signal.

This function is recommended for all applications where a valid data stream is continuously arriving at the error detector.

For measurements with partly invalid data, such as burst tests, this function may cause a clock loss. In such cases, deactivate **Auto Threshold** and

- enter a fixed voltage level manually, or
- press the **Measure** button to measure the voltage level of the incoming signal while a burst signal is applied.

Once the level is defined, it remains fixed for the following measurements.

Note that the entered voltage level has to be within the input range of the error detector. If the value lies outside this range, the change is rejected and an error message is displayed.

CDR Spread Spectrum Clocking

The CDR Spread Spectrum Clocking is available only with the option CTR / upgrade UTR.

This control is used to adapt the CDR to an input bit stream with SSC. Enable widens the loss of lock detection window, and sets the peaking to optimum SSC performance. Enter the Expected Deviation to set the locking window to an optimum.

SSC is mostly used “down-spread” which means, the clock signal is modulated to a lower frequency and back. Thus the average frequency is lowered by half of the maximum deviation. The CDR is adapted to that value. Enter the maximum deviation as most standards specify.

NOTE

Although the CDR will lock even without the presence of SSC, it is strongly recommended to uncheck this box when SSC is not present; otherwise the CDR will unnecessarily loose performance in lock detection and lock time.

Sampling Point Setup

Sampling Point Setup - Concepts

This section provides basic information on the sampling point setup and eye diagrams.

How Does the Sampling Point Setup Work?

The sampling point of a data signal is defined by two values: a point in time and a voltage level. Each bit of the data signal is sampled at this point in time and in reference to this voltage level. The point in time (in reference to the clock signal) is referred to as the *data input delay*, and the voltage level is referred to as the *0/1 decision threshold*.

The location of the sampling point is the decision factor as to whether the incoming bits are identified as logic 0's or 1's. To measure the accurate bit error ratio at the input port, false readings of logic 0's or 1's must be avoided. Therefore, the sampling point must be set to the optimum location within the data eye.

The functions within the **Sampling Point Setup** window allow you to:

- Prepare the error detector for the incoming data signal regarding the connector termination.
- Graphically display the eye diagram in terms of voltage, input delay and a BER threshold.

- Adjust the location of the sampling point.

What is an Eye Diagram?

An eye diagram provides a way to view all possible transitions between adjacent bits of a data stream by overlaying them on the display of a high-speed oscilloscope. It is typically produced by triggering the oscilloscope with a synchronous clock signal.

When the oscilloscope is triggered by a clock signal, data patterns will not be examined. Instead, if persistence is set high enough, the shape of an "eye" will be observed. The eye is bounded by overlaid logic 1 and 0 voltages (top and bottom) and multiple 0 to 1 and 1 to 0 transitions (left and right).

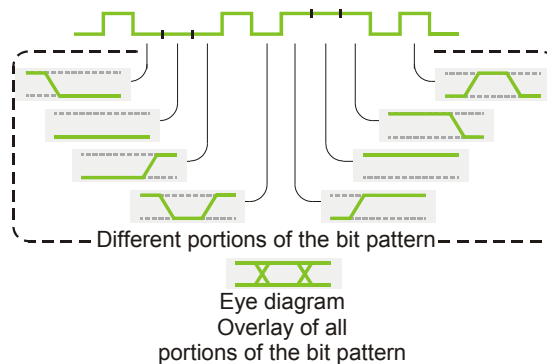

The sampling point of the error detector must be set within the data eye. The error detector uses the eye diagram to graphically display the location of the sampling point. Additionally, the appearance of the eye is useful for determining the quality of the data signal.

The height and width of the eye in the eye diagram are also displayed in the diagram. Rise time, overshoot, and jitter are not displayed in the diagram. Note that the diagram does not reflect the different shapes of signals in RZ or R1 pulse format.

What is an Eye Edge?

In the eye diagram, the eye has 4 edges. An eye edge is defined as a data input delay value or 0/1 threshold voltage value in the data eye that meets the following conditions:

- The instantaneous bit error ratio (BER) is greater than or equal to the alignment BER threshold.
- An adjacent point has an instantaneous BER that is less than the alignment BER threshold.

4 Setting up the Error Detector

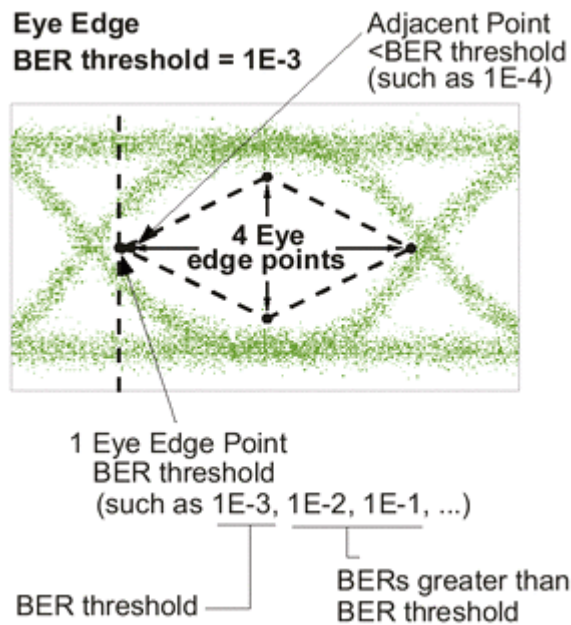

Understanding Bit Recovery Mode

In bit recovery mode (BRM), the error detector does not expect any particular pattern. Nevertheless, it detects bit errors.

In bit recovery mode, the error detector uses two sampling points. The second sampling point is not visible. Both are set to the expected optimum position when the **Auto Align** button is pressed (with respect to clock rate, signal voltages and offset, decision threshold, and so on).

The bits received at this sampling point are considered to be correct.

You can now move the visible sampling point and investigate the behavior of the DUT in detail. The error detector compares the bits at your sampling point with the bits recognized at the hidden sampling point. As you move the visible sampling point, the indicated BER will increase.

NOTE

The indicated BER is a *relative BER*. It approaches the absolute BER if the error ratio at the initial sampling point is very low. It is identical with the true BER if the signal at the initial sampling point is error free.

In bit recovery mode, some restrictions apply:

- Synchronization is impossible, because no particular data is expected. **Sync now** and **auto synchronization** functions are disabled.

- Burst mode is disabled.
- Error Location Capture cannot be used.
- The function **Error Detector Pattern tracks the Pattern Generator Pattern** is disabled. This function is not re-enabled when the BRM is terminated.
- BRM does not work above 11.5 Gb/s when the CDR is enabled. CDR > 11.5 GHz is only available with the full range CDR (N4903A SER No. DE46Bxxxx or Option CTR/Upgrade UTR).

BRM indicators:

- The mode is indicated in the status panel and in the BER Bar.
- The mode is indicated in all screen dumps and log files.
- The Measurement User Interface shows when this mode is used.

Sampling Point Setup - Procedures

In most cases you will set up the sampling point automatically. Even if you wish to make some manual adjustments, it is recommended to start with automatically aligning the sampling point.

NOTE

Before adjusting the sampling point, make sure the pattern synchronization mode is set up properly. See [“Pattern Synchronization - Procedures” on page 150](#) for details.

How to Set the Optimum Sampling Point Automatically

- 1 Click the **Sampling Point Setup** icon in the **ED Setup** menu.
- 2 Select an appropriate BER threshold from the **BER Threshold** list.
- 3 Press **Auto Align** to automatically set the optimum sampling point.

You can stop the search for the optimum sampling point at any time by pressing **Cancel**.

How to Adjust the Data Input Delay

- 1 Press the **Sampling Point Setup** icon in the **ED Setup** menu.
- 2 Select the **Avg. 0/1 Threshold** checkbox to use a good start point on the vertical voltage axis.

4 Setting up the Error Detector

- 3 Click **Data Center** to move the sampling point horizontally towards the center of the eye at the selected voltage. You may click **Cancel** at any time.
- 4 Now you can use the numeric keypad or front panel knob to manually adjust the value in the **Data Delay** field.

The **Sample Point** in the eye diagram moves horizontally as you change the value.

TIP

While adjusting the data input delay, you can monitor the **BER** bar on the analyzer display, or listen to the BER warning tones. Higher BERs may indicate that you are measuring at the edges of the data eye.

NOTE

Pattern synchronization can be lost during sampling point adjustment. If **Auto Sync** is enabled, the Serial BERT will resynchronize the patterns automatically. If the manual synchronization mode is selected, you need to synchronize the error detector by clicking the **Pattern Sync** icon and then the **Sync Now** button.

How to Adjust the 0/1 Decision Threshold

- 1 Press the **Sampling Point Setup** icon in the **ED Setup** menu.
- 2 Clear the **Avg. 0/1 Threshold** checkbox.
- 3 Click **0/1 Threshold Center** to move the sampling point vertically towards the center of the eye at the selected delay. You may click **Cancel** at any time.
- 4 Now you can use the numeric keypad or front panel knob to manually adjust the value in the **0/1 Threshold** field.

The **Sample Point** in the eye diagram moves vertically as you change the value.

TIP

While adjusting the 0/1 threshold, you can monitor the **BER** bar on the analyzer display, or listen to the BER warning tones. Higher BERs may indicate that you are measuring at the edges of the data eye.

NOTE

Pattern synchronization can be lost during sampling point adjustment. If **Auto Sync** is enabled, the Serial BERT will resynchronize the patterns automatically. If the manual synchronization mode is selected, you need to synchronize the error detector by clicking the **Pattern Sync** icon and then the **Sync Now** button.

How to Enable the Bit Recovery Mode

The bit recovery mode (BRM) allows you to measure the relative BER without knowing the incoming data pattern.

To enable the bit recovery mode:

- 1 Press the **Sampling Point Setup** icon in the **ED Setup** menu.
- 2 Click the **Bit Recovery Mode** button.

The **Sync Now** button is no longer available.

Note that you can also enable the bit recovery mode from the **Pattern** window. Click the **Pattern Select** icon and then the **Error Detector Pattern** tab. If this tab is not available, disable the checkbox **Error Detector Pattern tracks the Pattern Generator Pattern**.

- 3 Click the **Auto Align** button.

Sampling Point Setup - Reference

NOTE

Depending on the options of your Serial BERT, some of the following functions may not be valid for your instrument. See [“Introduction to the Serial BERT - Concepts” on page 9](#) and [“Which Features are Available?” on page 11](#) for a description of the available options.

The **Sampling Point Setup** window provides the following elements:

0/1 Threshold

The 0/1 decision threshold is the reference voltage level for the evaluation of the incoming data signal. At the sampling point, the data signal voltage is compared to the 0/1 decision threshold. Signals greater than this threshold will be measured as a logic 1; signals below this threshold will be measured as a logic 0.

NOTE

0/1 Threshold cannot be used while **Avg. 0/1 Threshold** is selected.

The **0/1 Threshold** field allows the manual entry of the 0/1 threshold, and displays the current value in millivolts.

You can adjust the 0/1 threshold in the following ways:

- Click inside the text field and use the numeric keypad or front panel knob to enter a value.
- Click anywhere in the sampling point display. The sampling point will be moved to that location.
- Turn the **Decision Threshold** knob on the front panel. A small window appears, displaying the threshold value. This knob can be used at any time, while in any window.

Data Delay

The data input delay defines the point in time (in reference to the clock signal) at which the incoming data signal is measured. Specifically, it is the time delay from the active clock edge to the time at which the data is actually sampled.

This field allows the manual entry of the data input delay, and displays the current value in picoseconds. This delay can be set as high as 1 bit period or 10 ns (10,000 ps), whichever is less.

You can adjust the data input delay in the following ways:

- Click inside the text field and use the numeric keypad or front panel knob to enter a value.
- Click anywhere in the sampling point display. The sampling point will be moved to that location.
- Turn the **Data In Delay** knob on the front panel. A small window will appear, displaying the delay value. This knob can be used at any time, while in any window.

Clock Falling Edge

Activate this checkbox to move the sampling point from the rising edge to the falling edge of the clock signal. This function is useful when the maximum data input delay adjustment is not large enough to move the sampling point to the desired location. This occurs at very low frequencies only. See [“Bit Rate Range” on page 119](#) for more information.

Auto Align

Click this button to automatically set the optimum sampling point.

This routine will not stop if the optimum sampling point cannot be found. If no optimum sampling point is found after a reasonable time,

you can click **Cancel**. The status message bar will indicate if this function is unsuccessful.

The following settings may affect the result of the auto align function:

- **Data Inverted**
- **BER Threshold**

TIP

Alternatively, you can also press the **Auto Align** button on the front panel.

Sync Now

Click this button to manually start a pattern synchronization. See [“What Type of Synchronization Should You Use?” on page 141](#) for information on when you should use this function.

Note that this button is not available in bit recovery mode.

0/1 THReshold Center

Starts an auto-search function that sets the 0/1 threshold to the optimum point of the incoming data eye on the vertical voltage axis without changing the data input delay. This function can be used for determining the optimum 0/1 threshold for asymmetric data eyes, or for patterns with an unequal mark density.

The status message bar will indicate if this function is unsuccessful. This function clears the **Avg. 0/1 Threshold** checkbox.

NOTE

This function uses the alignment **BER Threshold** to determine the top and bottom eye edges.

Data Center

This button starts an auto-search function that aligns the data signal with the clock signal so that the error detector samples at the optimum point of the data eye in the time axis. This automatically compensates for delays in the clock/data paths, preventing unnecessary errors. The 0/1 decision threshold is not changed. The status message bar will indicate if this function is unsuccessful.

NOTE

Ensure that the received clock frequency is stable before using **Data Center**.

TIP

The clock/data alignment process time is pattern dependent, and with some large user patterns the alignment can take several minutes. If you encounter such a long time with a user pattern, it may be possible to first perform clock/data alignment on a pure PRBS pattern. This generally does not affect alignment accuracy, and can minimize measurement time.

This tip does not apply in cases of severe pattern dependent jitter or with devices that do not work with PRBS patterns.

NOTE

This function uses the alignment **BER threshold** to determine the left and right eye edges.

Cancel

Click this button to cancel the **Auto Align**, **0/1 Threshold Center**, or **Data Center** functions while they are in progress. The following parameters will be returned to their previous value or status:

- **Auto Align** Canceled
 - **Data Delay** and **0/1 Threshold** values returned to previous.
 - Status of **Data Inverted** and **Avg. 0/1 Threshold** checkboxes returned to previous.
- **0/1 Threshold Center** Canceled
 - **0/1 Threshold** value returned to previous.
 - Status of **Avg. 0/1 Threshold** checkbox returned to previous.
- **Data Center** Canceled
 - **Data Delay** value returned to previous.

BER Threshold

In this list, select an alignment BER threshold that is appropriate for your application.

The alignment BER threshold is the pre-defined threshold used by the **Data Center**, **0/1 Threshold Center**, and **Auto Align** functions to define the edges of the data input eye in the time and voltage axes. You may wish to change the threshold for the following reasons:

- Choosing smaller alignment BER thresholds will cause the auto-search functions to set more accurate sampling points. However, if the BER threshold is set lower than the residual BER of the measurement, the auto-search functions will fail. 1E-7 is the smallest BER threshold available.

- Running the auto-search functions and viewing eye results at different BER thresholds will allow you to see the eye margin at specific BERs. You can also construct basic eye contour information.

Avg. 0/1 Threshold

Activate this checkbox to make the error detector continuously set the 0/1 threshold level to the average DC voltage level of the incoming data signal.

NOTE

Manual 0/1 threshold changes are impossible while this function is selected.

This function is useful for providing a "starting point" for sampling somewhere within the data eye on the vertical voltage axis. It is recommended to use this prior to clock/data alignments.

When used with the following patterns, this function may provide a 0/1 threshold that requires no further adjustment:

- 2^{n-1} PRBS patterns
- Patterns with 50% mark densities (large amplitudes and no excessive noise)

Bit Recovery Mode

Click this button to put the error detector in bit recovery mode (BRM). For details on BRM see [“Understanding Bit Recovery Mode”](#) on page 128.

Then, click **Auto Align** to set the sampling point.

Sampling Point Display

This area of the **Sampling Point Setup** window graphically illustrates the parameters of the current sampling point and data eye. Click anywhere in the sampling point display to set the sampling point to that location.

4 Setting up the Error Detector

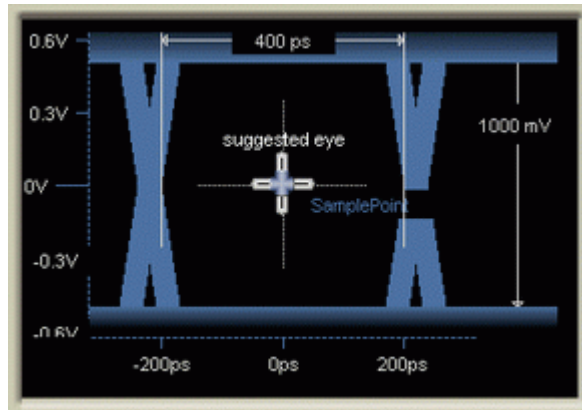

A green area in the display indicates the voltage range specified in the **Input Range** fields for non-differential modes (Normal and Complement). The Serial BERT is searching this range to find the eye when calculating the optimum sampling point.

Return to Results

Click this button to return the **0/1 Threshold** and **Data Delay** to the values measured during the last auto alignment. The **Data Inverted** and **Avg. 0/1 Threshold** checkboxes will be returned to their previous state.

Trigger and Aux Output

Trigger and Aux Output - Concepts

The error detector has a Trigger Out and an Aux Out port that you can use to send signals to other external devices such as an oscilloscope.

The Trigger Out can be set up to send a trigger to an external device either according to the clock, or according to the data pattern being generated.

The Aux Out can be set up to either send the error detector's clock signal directly from Clk In port, or the error detector's clock signal recovered from Data In port, or the input data passed over a comparator.

Trigger and Aux Output - Procedures

To set up the trigger and auxiliary outputs:

- 1 Press **Trigger and Aux Out** in the **ED Setup** menu.
- 2 For the **Trigger**, select one of the two options:
 - **Clock Divided by n**
Sends a trigger signal every **4, 8, 16, 20, 32, 64**, or **128** bits.
 - **Pattern**
A trigger is sent, every time the complete pattern was received.
- 3 For the **Aux Out**, select whether the **Clock** signal or the **Data** signal is supplied.

If **Clock** is selected, the clock signal used by the error detector is output directly at Aux Out.

If **Data** is selected, the input data is output over a comparator at Aux Out.

The comparator is controlled by the 0/1 threshold. This lets you use an oscilloscope to determine if the 0/1 threshold is correctly set. If the 0/1 threshold is set below or above the data eye, the output at Aux Out will be constant high or low, respectively.

- 4 Click **OK** to finish the **Trigger and Aux Out** setup.

Trigger and Aux Output - Reference

The available options in the **ED Trigger & Aux Output** window are:

Trigger

You have two options to configure the signal at the Trigger Out port:

- **Clock Divided by n**

The trigger is set every **n** bits.

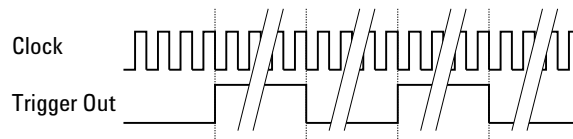

- **Pattern**

4 Setting up the Error Detector

The trigger signal is sent every time when the complete pattern has been received. This refers to the single pattern repetitions, not the 512-bit blocks.

Note, that the length of the trigger signal is at least 40 bits and divisible by 4.

Aux Out

You have two options to set up the signal at the Aux Out port:

- **Clock**

This option supplies the clock signal to the Aux Out port.

- **Data**

This option supplies the data signal via a comparator to the Aux Out port.

The comparator is controlled by the 0/1 threshold. This lets you use an oscilloscope to determine if the 0/1 threshold is correctly set. If the 0/1 threshold is set below or above the data eye, the output at Aux Out will be constant high or low, respectively.

Pattern Synchronization

Pattern Synchronization - Concepts

The Serial BERT calculates bit error rates by comparing the received data with the expected data patterns. To do this, it needs to know where the start of the pattern is located in the data stream.

Introduction to Pattern Synchronization

Pattern synchronization (sync) refers to aligning the incoming data pattern with the internal reference pattern. This is accomplished in one of two ways:

Hardware-Generated Patterns

For 2^n-1 PRBS patterns, bits from the incoming data pattern "seed" the error detector's pattern generator, causing it to generate a precisely aligned internal reference pattern.

Memory-Based Patterns For software-generated and user patterns, a 48-bit pattern from the pattern is used as a *detect word*. Optimally, this detect word should be unique within the entire pattern. The error detector searches for this detect word within the incoming data stream, and uses the point in the data stream as a reference, and compares all following bits with the pattern. If the measured BER is better than the synchronization BER, the error detector is synchronized.

There are thus three possible outcomes for a synchronization:

- Single instance of the detect word in the data stream

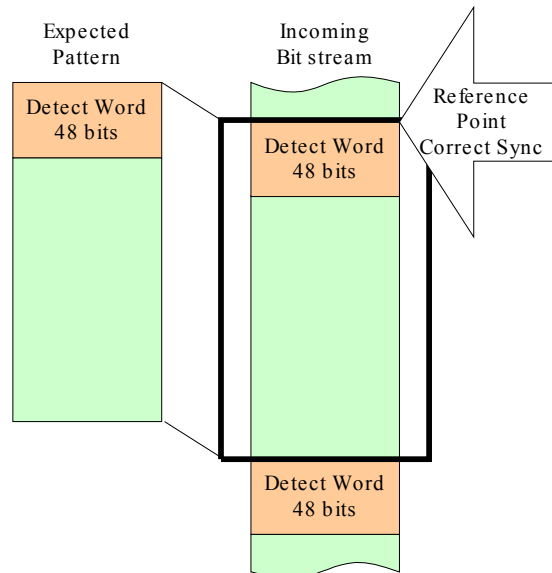

- Multiple instances of the detect word with correct synchronization

4 Setting up the Error Detector

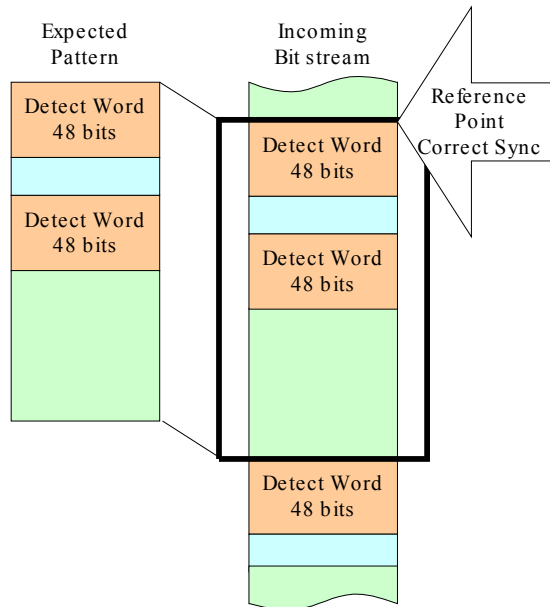

- Multiple instances of the detect word with false synchronization

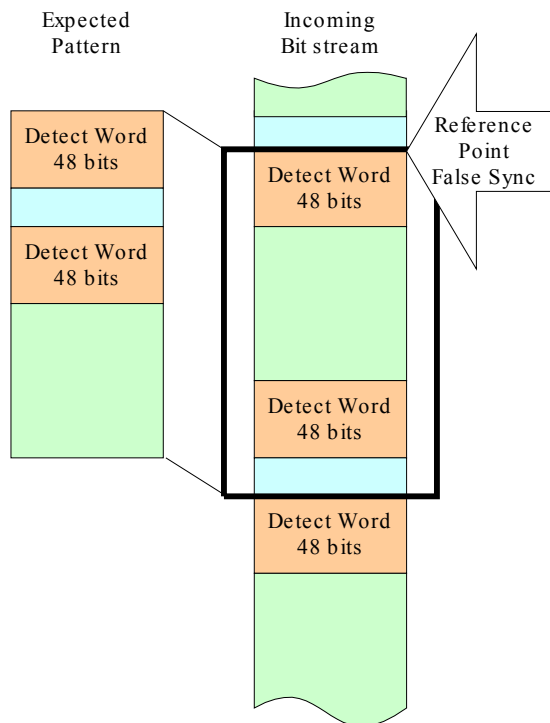

If the error detector attempts to synchronize on the incorrect detect word, the BER will be unacceptably high, and, if automatic synchronization is selected, the error detector attempts another resync.

The detect word on which the error detector attempts to resync is chosen strictly by chance. So if there are two instances of the detect word in the pattern, the error detector has a 50% chance of selecting the correct one.

The more instances of the detect word exist in the pattern, the higher are the chances for incorrect synchronization. The software attempts in any case to identify a 48-bit pattern that occurs as seldom as possible in the pattern. For very large patterns, this can unfortunately take a very long time, and the software ends the search if it expects that it would take longer to find an adequate detect word than it would to attempt to synchronize. If the search for a detect word is ended, the most unique detect word identified is used.

Further Considerations Patterns must always be synchronized in order to do accurate BER testing. If patterns are out of alignment by just one bit, errors can be as high as 50% (5E-1) for PRBS patterns, and 100% (1E+0) for custom patterns.

By default, the error detector is in automatic sync mode with a sync threshold of 1E-3. This setting is recommended for most applications, and usually allows the synchronization function to be "transparent", requiring no attention. However, for special applications, changes can be made to the sync mode and sync threshold.

What Type of Synchronization Should You Use?

The type of synchronization you use affects how errors are measured and displayed. A **Sync Loss** is recognized when the BER is greater than the sync threshold. This can be caused by a high error rate, pattern misalignment, or clock loss. Choose the sync mode setting that is appropriate for the type of errors you anticipate.

- Automatic Sync with a sync threshold BER of 1E-3 is recommended for most applications.

With this mode selected, the synchronization algorithm starts whenever the BER exceeds the threshold. However, it is not possible to make accurate BER measurements higher than the sync threshold.

- Manual sync can be used for synchronizing once, confirming proper pattern alignment, and then measuring BERs higher than the sync threshold. This is useful for the following applications:
 - To monitor the integrity of clock signals. You may wish to measure BERs that exceed the sync threshold to confirm clock slip.
 - To collect data for constructing eye contour information. You may wish to move the sampling point to locations in the data eye that have BERs exceeding the sync threshold.

This mode doesn't allow the analyzer to automatically synchronize if the BER becomes greater than the sync threshold. For example, the analyzer will not re-synchronize after momentary clock loss.

NOTE

Adjusting the data input delay may cause momentary clock loss. If you select Manual Sync mode, this may also result in sync loss.

- Burst sync mode is a special operating mode for measuring data in bursts of bits, rather than one continuous stream of bits.

For more information, refer to [“Introduction to Burst Sync Mode” on page 144](#).

NOTE

If the error detector is in Manual Sync mode, it is recommended that you keep an eye on the SYNC LOSS light at the top of the instrument. There are various actions that can lead to loss of synchronization. Check the SYNC LOSS any time you make changes to the instrument.

What is False Synchronization?

For patterns other than PRBS, the error detector may gain sync at a point in the pattern that meets the sync threshold, but is not the correct point where the internal reference pattern and the received data pattern match. This is called false synchronization.

NOTE

False synchronization cannot occur with PRBS patterns because a 1 bit misalignment would cause a measurement of 50% or more errors. Thus, the BER during a misalignment would always be greater than the sync threshold BER.

For example, consider a pattern of 1000 ones and 1000 zeros as shown in the following figure. With reference alignment 1 the patterns are totally out of phase and the error detector is measuring 100% errors. But as the reference moves closer to optimum alignment, the percentage of errors gradually approaches zero (reference alignment 2 and 3). For exact alignment, the sync threshold must be set lower than the BER caused by a 1 bit misalignment, in this case $1E-3$.

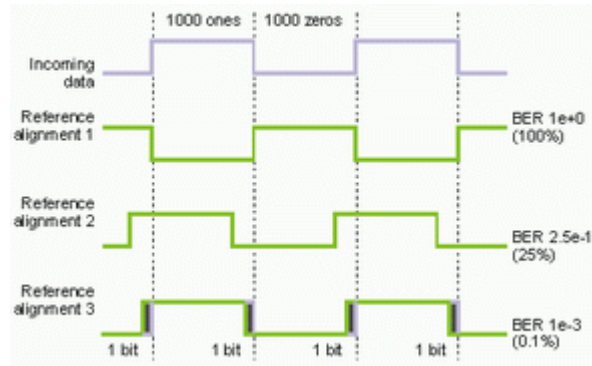

How Can You Tell if Your Synchronization is False?

You may suspect false synchronization under the following conditions:

- You are using a pattern other than PRBS and the error detector gains sync, but it measures a constant, fixed error ratio.
- You are using a pattern other than PRBS and the error detector gains sync, but auto-search functions (Auto Align, Clock/Data Center, 0/1 Threshold Center) repeatedly fail.

In a false sync, the sync threshold BER of 1E-3 may be met, but eye edges at BER 1E-3 (required by an auto-search function) may not be found. This is because BERs less than 1E-3 do not exist within the data eye.

4 Setting up the Error Detector

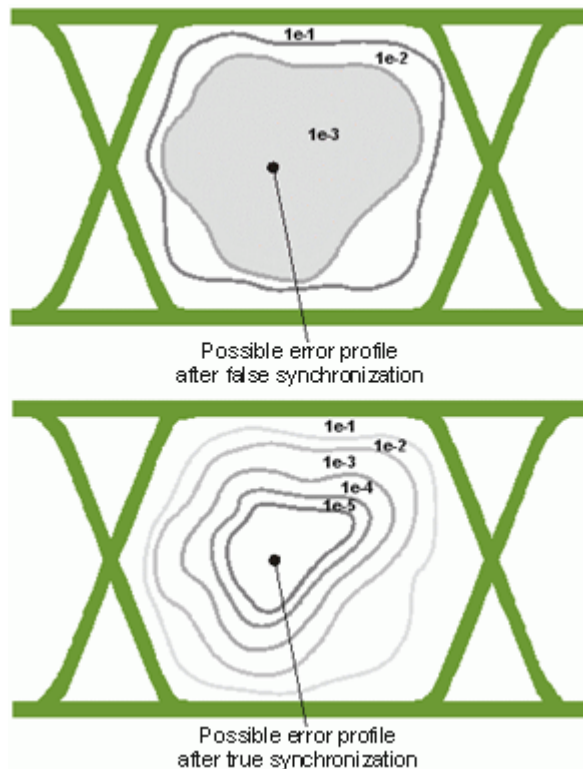

If you suspect a false sync, try re-synchronizing at a sync threshold BER lower than the fixed error ratio. If sync is acquired without the problems listed above, then your previous sync was false. Your current sync should be on an exact pattern alignment.

NOTE

While auto-search functions are in progress, the sync threshold BER is changed to the same value as the alignment BER threshold. If you are using these functions and want to consistently re-synchronize at a lower sync threshold, you must set the alignment BER threshold to the same value as the sync threshold BER.

Introduction to Burst Sync Mode

The burst sync mode is a special operating mode for measuring data in bursts of bits, rather than one continuous stream of bits.

The burst sync mode measures bit error rates for each burst of data after the error detector synchronizes to the incoming pattern. The signal at the Gate In port controls the timing of synchronization and error counting for each burst.

This function is useful, for example, to analyze recirculating loop data. With a recirculating loop you can simulate very long cable connections like transoceanic cables. Data is sent into a looped cable drum and after

a certain number of loops it is diverted into the error detector. This way, only a short burst of valid data reaches the Serial BERT followed by a long break. Therefore, the error detector needs to be synchronized at the beginning of every burst.

How Burst Sync Mode Works

The following figure presents the basic order of events that make up a burst mode measurement. It also illustrates how the instrument operates while in burst mode.

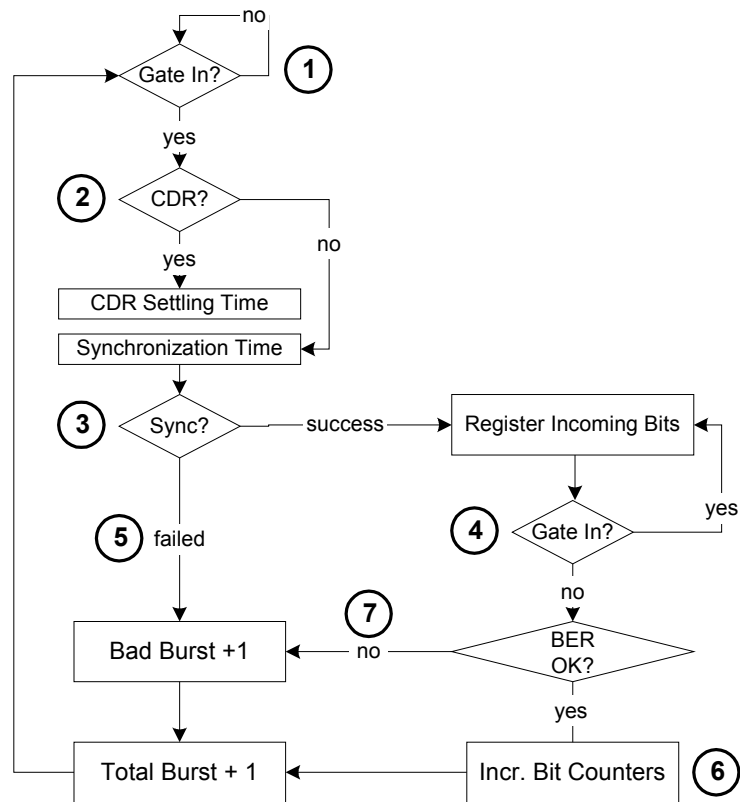

NOTE

Burst mode requires a complete measurement setup, including an external input for the Gate In port. This input is used for the sync alignment.

- 1 Burst sync is started when the Gate In signal goes low, indicating that a burst is arriving at the Data In port.
- 2 If the error detector is in CDR mode, it first tries to generate a clock from the data. A short time interval is required to stabilize the clock (the CDR settling time).

Note that if the error detector is in CDR mode, it is necessary to set a CDR threshold. This is the BER threshold that the error detector uses to verify that the input pattern is synchronized. See “[How does Clock Data Recovery Work?](#)” on page 117 for more information.

If an external clock is used, there is no delay. The clock signal must however be continuous.

- 3 The error detector can then synchronize to the incoming signal. For PRBS, the first received bits are used to seed the synchronization. If there is an errored bit in this phase, the synchronization fails (bad burst).

For memory-based patterns, a unique 48-bit detect word is used for the synchronization. This pattern should be available one time only in the pattern. If the detect word is not found, synchronization fails (bad burst).

- 4 If synchronization has been established, the received data is analyzed until the signal at Gate In goes high, indicating the end of the burst. The data should continue arriving at Data In slightly longer than the Gate In signal.
- 5 In case of failed synchronization, the total burst counter and bad burst counter are incremented. The bit counters (total count, error count, etc.) are not incremented.
- 6 At the end of the burst, the data is analyzed: the bits are counted, as are the errors (total, errored 0s, errored 1s).

If the BER is higher than the **Burst Sync Threshold** (in the Pattern Sync Setup dialog box), the burst is considered a bad burst, and the total burst count and bad burst count are incremented.

- 7 For good bursts, the total burst count is incremented, and the bits are analyzed (bits and errors counted). The BER is also shown in the user interface.

Timing of the Signal at Gate In

The timing of the signal at Gate In is critical to the successful use of burst mode. If the signal is not timed optimally, the resulting BER will be either too high, or the sync ratio (good bursts / total bursts) will be too low.

The signal at Gate In has to start early enough for the error detector to get the clock (the CDR settling time) and synchronize to the pattern. And it has to stop before the burst ends, but should stay low as long as possible without hitting the maximal length limitation (to extend the time where bits can be counted).

The following figure illustrates how the duration of the Gate In signal can influence the bit count time (the time where bits are actually counted).

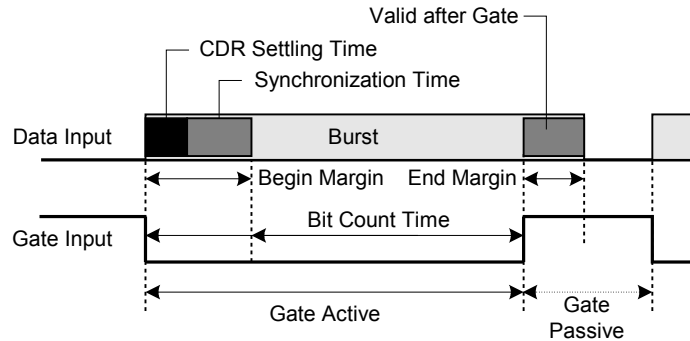

Gate Active is the interval in which the Gate In signal is active.

The **Bit Count Time** is the part of the burst from which the bits can actually be counted. The remainder of the burst is covered by the **Begin Margin** and **End Margin**.

The **CDR Settling Time** is the time that the error detector requires in CDR mode to get the clock from the data stream.

The **Synchronization Time** is the time the error detector requires to synchronize to the pattern. This time depends on the pattern type (PRBS or memory-based).

The **Valid after Gate** indicates the minimum length of data that has to arrive at Data In after the Gate In signal is deactivated.

Interval between Bursts

There is no requirement how long a signal should be available at Data In before gating starts (the data should simply be stable). A pause is however required after the gating to allow the error detector to evaluate the results. This time is known as **Gate Passive**.

The following is a summary of the values of these parameters for the Serial BERT:

Table 15

Parameter	Values
Bit Count Time	Min.: 1536 bits Max: 4 Gbits The optimal length is dependent on the BER threshold.

Table 15

Parameter	Values
CDR Settling Time	CDR mode: 2 microseconds Non-CDR mode: 0
Synchronization Time	Hardware PRBS: 1536 bits Memory-based patterns: Min. 15 kbits (depends on when and how often the unique word occurs)
Valid after Gate	CDR mode: 1.5 microseconds Non-CDR mode: 1536 bits
Gate Passive	CDR mode: 2560 bits or 1.5 microseconds (whichever is larger) Non-CDR mode: 2560 bits

The following values can be derived from these parameters:

Table 16

Parameter	Values
Begin Margin	CDR Settling Time + Synchronization Time
End Margin	Valid after Gate
Bit Count Time	Burst Length - Begin Margin - End Margin
Gate Active	Begin Margin + Bit Count Time

Optimizing the Timing

There are three things to watch when optimizing the timing for burst sync mode:

- BER
The bit error rate increases when the gate closes too late. The duration of the signal should typically be reduced.
- Burst sync ratio

The burst sync ratio is an indication of how much of the burst signal is in synchronization (and can therefore be used for counting bit errors). The higher the value, the better.

- **Bad burst count**

The bad burst count counts the number of bursts that are invalid (for example, because synchronization failed or the BER of a synchronized burst exceeds the sync threshold).

The following describes how changing the Gate In start and end points can affect the evaluation of bursts.

Gate In Start Starting too soon: If the Gate In signal is applied too soon, the error detector will either not be able to recover the clock or synchronize the pattern, and will thus mark the burst as a bad burst (thus increasing the bad burst count). You can typically reduce the bad burst count by starting the gating period later.

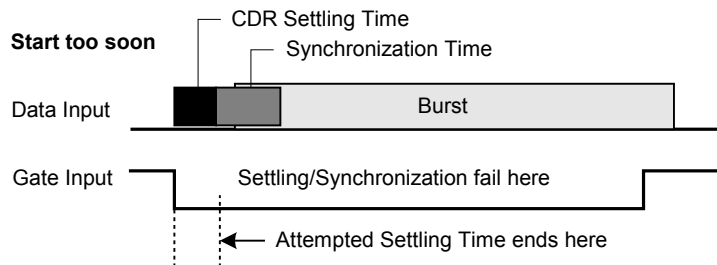

Starting too late: If the Gate In signal is applied too late, the Bit Count Time will be shortened, and thus the burst sync ratio will be low (which forces the measurement of more bursts to obtain the necessary level of reliability).

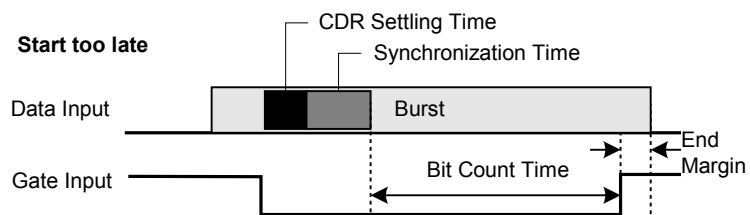

Gate In End Ending too soon: If the Gate In is deactivated too soon, the same problems will occur as with starting the gate too late (see previous point).

4 Setting up the Error Detector

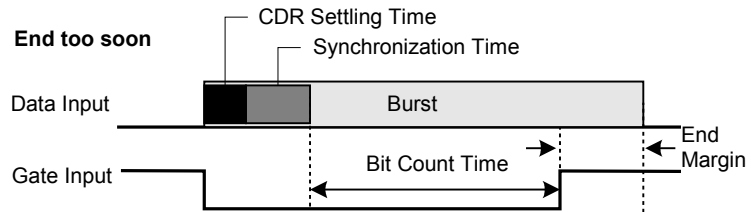

Ending too late: If the Gate In signal is deactivated too late, the last received bits will not be part of the burst. Thus, the BER will increase. If the BER is higher than the Burst Sync Threshold, the burst will be considered a bad burst.

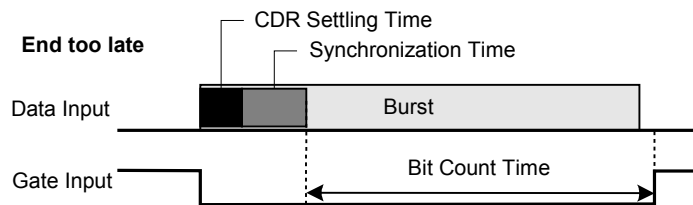

Pattern Synchronization - Procedures

To synchronize the incoming pattern to the expected pattern:

- 1 Press **Pattern Sync** in the **ED Setup** menu.
- 2 Select the synchronization mode (**Normal** or **Burst** sync mode).
- 3 If you selected **Normal** synchronization mode, choose whether you want **Automatic** or **Manual** synchronization.
- 4 Specify the **Sync Threshold** at which the pattern will be recognized at synchronized.
- 5 In **Manual** synchronization mode use the **Sync Now** button to start the pattern synchronization. This is recommended whenever you did changes to the pattern setup, the voltage levels or the hardware connections (for example, altered cable lengths).
- 6 Press **OK** to confirm your settings.

Pattern Synchronization - Reference

The error detector can synchronize the data patterns in the following ways:

- In **Normal Sync Mode**, you can choose between
 - **Automatic Sync**

With this option selected, the error detector constantly tries to synchronize the patterns when the BER threshold is exceeded.
 - **Manual**

Manual synchronization can be selected, for example, if the signal delay is very unstable, and you want to avoid that the re-synchronization process affects the measurement results.
- **Burst Sync Mode**

Click this button to enable the **Burst Sync Mode**. Burst mode operates as follows: For each burst of data, BER measurements are only made after the error detector synchronizes to the incoming pattern. The signal at the Gate In port controls the timing of synchronization and error counting for each burst.

The **Sync Threshold** defines when the error detector assumes the patterns to be synchronized. The Serial BERT shifts the received pattern bitwise until the measured BER is below this threshold.

Error Accumulation

Error Accumulation - Concepts

The Serial BERT instantly starts measuring the BER when the error detector receives data. However, to perform tests that can be repeated and compared, you can collect the measurement data in several ways and save it to a log file.

The available options are to test:

- for a specified time,
- until a certain number of errors occurred,
- until a specified number of bits have been sent,

- until you stop it manually.

Error Accumulation - Procedures

To set up the Serial BERT for error accumulation:

- 1 Press the **Accumulation Setup** icon in the **ED Setup** menu



- 2 Select the desired **Activation Mode** for the type of test you want to run (**Manual**, **Single**, or **Repeat** test).
- 3 If you selected a **Single** or **Repeat** test, you need to specify the accumulation **Period** (certain **Time**, **Number of Errors**, or **Number of Bits**).
- 4 Use the **Measurement Logs** area to specify whether you want save the results in a log file.
- 5 The log files will be saved in the **Log Directory** displayed at the bottom of the dialog box. Use the **Browse** button to select a different directory.
- 6 Click **OK** to apply your selections and close the **Accumulation Setup** dialog box.

For more information on how to run error accumulation tests, see [“How to Run Accumulated Measurements”](#) on page 303

Error Accumulation - Reference

The **Accumulation Setup** window contains the following elements:

Activation Mode

- **Manual**
Activate this option to configure the error detector to start and stop accumulation when the front panel buttons are pressed.
- **Single**
Activate this option to configure the error detector to accumulate over one accumulation period and then stop.

- **Repeat**

Activate this option to configure the error detector to accumulate over repeated accumulation periods, whereby one period follows another immediately. There is no "dead time" between the end of one period and the start of the next.

NOTE

Repeat will not create multiple measurement log files. The data for all repeating periods will be saved to the same log file.

The accumulation mode cannot be changed while accumulation is running.

Measurement Log

- **Prompt for File Name**

Click this option if you want to be prompted for a measurement log file name before each accumulation period begins. With this option you can select a new file name for each test run.

- **File Name**

Click this option if you want to enter a file name for measurement logs before starting the accumulation. With this option you will overwrite the measurement log file with each new test run. However, in **Repeat** mode, the results of all repetitions will be appended to this file and no information is lost.

- **No Logging**

Click this option to turn off measurement logging. Serial BERT will not save the test results.

Period

The accumulation period cannot be specified for **Manual** tests.

- **Time**

Select this option to configure the error detector to accumulate bit errors for a specific period of time.

You can enter the desired time period in the **Days**, **Hr** (Hours), **Mn** (Minutes), and **Sec** (Seconds) fields. You may use the numeric keypad or front panel knob. The minimum value is 1 second and the maximum value is 99 days, 23 hours, 59 minutes, and 59 seconds. When the selected time has elapsed, the accumulation ends.

- **Number of Errors**

Select this option to configure the error detector to accumulate bit errors until a specified number of errors has been measured.

4 Setting up the Error Detector

The number of errors can be set to **10**, **100**, or **1000**. When the selected number of errors has occurred, the accumulation ends after the next full second.

- **Number of Bits**

Select this option to configure the error detector to accumulate bit errors until the specified number of bits have been examined.

The number of bits can be set from **1E7** to **1E15**. When the selected number of bits have been exceeded, the accumulation ends.

NOTE

The actual test period may contain more bits than specified.

NOTE

The accumulation period cannot be changed while accumulation is progress.

Browse

Click this button to browse for the directory where you wish to save the measurement log files.

NOTE

Changes to the parameters of the accumulation setup do not take effect until the start of the next accumulation.

BER Location

BER Location - Concepts

The Serial BERT can be run in BER location mode. In this mode, the errors are not counted on all bits of the data signal, but on a particular bit or block of bits in the pattern. You can specify which bit position(s) are considered during the measurement.

This allows, for example, to calculate the BER for the header bits or the payload of a data stream exclusively.

BER Location - Procedures

To set up the BER location mode, do the following:

- 1 Press the **BER Location** icon in the **ED Setup** menu.
- 2 Select whether you want to locate errors on **All Bits**, on a particular **Block** of bits, or on a **Single Bit** in the pattern.

If you select **Block** or **Single Bit**, enter the bit positions in the respective fields.

- 3 Click **OK** to finish the BER location mode setup.

BER Location - Reference

The Bit Error Location Mode dialog box offers the following options:

All Bits With this option, all errors are counted.

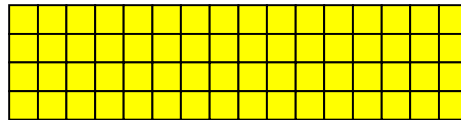

Block With this option, only errors occurring in the block between the specified **Start Bit** and **Block Length** are counted.

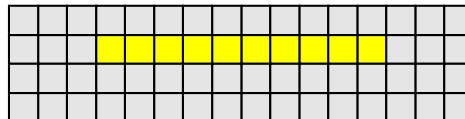

Single Bit With this option, only errors occurring at the specified position are counted.

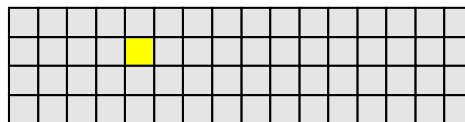

The following legend applies for the above graphics:

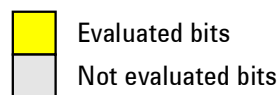

Audio Signals

Audio Signals - Concepts

The use of warning tones is convenient when you want to monitor the instantaneous BER over a longer time without constantly watching the display.

With the Audio dialog box, you can adjust the sound volume as well as some conditions when to play a sound is played.

Audio Signals - Procedures

To set up the warning sounds, do the following:

- 1 Press the **Audio** icon in the **ED Setup** menu.
- 2 Check the **Audio on** checkbox to switch on the sounds.

TIP

To switch the audio signals on and off, you can also use the **Audio On/Off** front panel button.

- 3 Use the **Main Volume** slider to adjust the volume.
After adjusting the slider, a test tone is played at the new volume.
- 4 Click the respective radio button if you want to play the sound
 - whenever the BER exceeds the threshold specified in the **BER Alarm Threshold** field. Enter an appropriate value in this field.

TIP

You can always adjust the **BER Alarm Threshold** by clicking and dragging the small yellow marker in the **BER** bar in the top left corner.

- on **All Error Rates** greater than zero.
- 5 Click **OK** to finish the audio setup.

Audio Signals - Reference

The **Audio** dialog box contains the following elements:

Audio on

Select this checkbox to enable the audio function.

Clear this checkbox if you want to switch off the audio function.

You can also use the **Audio On/Off** button on the front panel to accomplish the same function.

Main Volume

Click any point on the slider or drag it to change the main volume level. You will hear a test tone at the new volume level.

Audio on BER Alarm

Click this option to make the analyzer play warning tones when a specific BER is exceeded.

The **BER Alarm Threshold** is the threshold at which tones are produced.

Enter the BER threshold in the following format: (number)E (exponent). For example, 1.5E-3.

TIP

You can always adjust the **BER Alarm Threshold** by clicking and dragging the small yellow marker in the **BER** bar in the top left corner.

Tones on All Error Rates

Click this option to make the analyzer produce warning tones when any BER greater than zero is measured. The pitch will increase or decrease as the BER increases or decreases.

4 Setting up the Error Detector

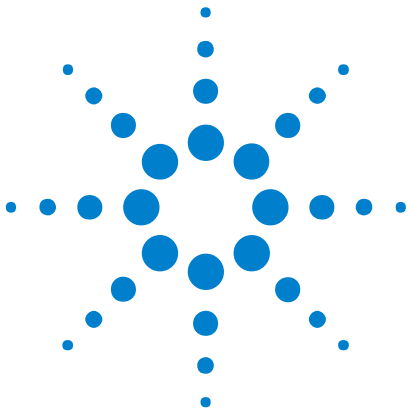

5 Advanced Analysis

Advanced Analysis - Concepts

The Serial BERT offers several different kinds of advanced measurements for various purposes:

- DUT Output Timing/Jitter** This type of measurement is used to measure the timing and jitter behavior for a device under test (DUT). It uses a bit error rate (BER) measurement to evaluate the shape of the eye for the output signal of the DUT. It also analyzes the jitter, separates the random jitter and deterministic jitter components, and estimates the total jitter.
- A direct result is the determination of the optimum sampling point delay for receiving data from the DUT with maximum confidence.
- DUT Output Timing/Jitter includes the Fast Total Jitter measurement that can be used to measure the total jitter for devices which generate a very low error density in a reasonable time span.
- Output Levels** The Output Levels measurement allows you to characterize the behavior of the output levels of a device under test (DUT). The sampling delay is fixed. The error detector's decision threshold is automatically swept within a user-defined range.
- A direct result is the determination of the optimum decision threshold level for receiving data from the DUT with maximum confidence.
- Eye Opening** The Eye Opening measurement generates a three-dimensional bit error rate (BER) diagram as a function of the sample delay and the sample threshold. With this measurement, the complete eye of the DUT output signal is measured. The results comprise the voltage and timing of the eye opening and the optimum sampling point.
- Error Location Capture** The Error Location Capture measurement allows to capture the actual position of errored bits in a memory-based pattern. The instrument searches for the first bit errored in the incoming bitstream and marks



it in the pattern. The address of the errored bits can be displayed after the error is located.

Fast Eye Mask The Fast Eye Mask measurement is first of all meant for production and screening tests. It allows to determine very quickly whether the eye opening seen at the output signal of a device is within specifications, that means, within certain timing and voltage limits.

This is achieved by measuring the bit error rate at a limited number of test points.

Eye Diagram The Eye Diagram allows a quick check for the DUT's signal output, and determines the signal quality. Due to the higher sampling depth of a BERT value, the eye contour lines display the measured eye at a deeper BER level, for accurate results.

Spectral Jitter The Spectral Jitter measurement allows you to analyze the jitter inherent in the output signals of your device under test (DUT) as a function of the frequency. This measurement can be used for investigating the behavior of the DUT, for example to identify crosstalk effects.

Before you can run any of these advanced measurements you have to properly set the required parameters. After the test is complete you can view the results.

General Requirements

For any measurement to yield reasonable results the following requirements apply:

- The error detector must be correctly set up and synchronized with the pattern sent from the DUT output port.
- Ideally, the sampling point should be aligned to the optimum sampling point (for example, with the **Auto Align** function).
- For low bit rates below appr. 620 Mbit/s only the Error Location Capture measurement works.

Please refer to [“Bit Rate Range” on page 119](#) for a detailed explanation of the limitations at low bit rates.

If the Serial BERT's pattern generator is used to send a data pattern to the DUT, then also the following conditions must be met:

- An appropriate pattern is selected.
- The pattern generator is correctly set up.

For examples, refer to the descriptions of the different measurements.

Optimizing Parameters

If the presented measurement results do not answer your questions adequately, you can easily modify the setup parameters in the **Properties** dialog box. When changing the measurement settings after the measurement has been run, please note:

- Parameters that affect the data capture.
Changes on the **Parameters** page take only effect if you run the measurement again.
- Parameters that change the display of the measured data.
Changes on the **Pass/Fail**, **View**, **Graph**, and **Color** tabs only affect the display of the results. There is no need to repeat the measurement.

Saving Measurements for Later Analysis

You can save a completed measurement for later analysis. This includes the settings you selected for the measurement and the measured data. This allows you to load the measurement at a later stage and inspect all data in detail. You can also change display parameters to evaluate this data even more thoroughly.

NOTE

When saving the measurement, the following settings are not saved:

- selected pattern
- settings of the pattern generator
- settings of the error detector

To save these settings, see [“Saving Instrument States” on page 421](#).

Besides saving a measurement as a file, you can also export the data to any spreadsheet application.

Advanced Analysis - Procedures

This section describes some basic functions that apply to all measurements.

If you want to store the measurement results for later use, you can either save them as an .mcp file (to be opened in the Serial BERT software) or as a .txt file for spreadsheet applications.

How to Save Measurements

To save a measurement as an .mcp file for later use in the Serial BERT user interface:

- 1 After your measurement has finished and the results are displayed, select **Save Measurement** from the **Analysis** menu.
- 2 Select a proper file name and location and press the **Save** button.

How to Export Measurements

To export the measurement data into a .txt file for later use in external spreadsheet applications:

- 1 After your measurement has finished and the results are displayed, select **Export Data** from the **Analysis** menu.
- 2 In the **Export** dialog box, select the path and file name for the .txt file.
Alternatively, you can activate the **Clipboard** checkbox to copy the data to the clipboard. In this case you can then paste it into any other application.
- 3 Press the **Format Options** button to open the **Export/Logfile Format** dialog box.
- 4 Make further selections for the format of the exported data. Press **OK** to close the dialog box.
- 5 Press **OK** to export the data to the specified destination.

How to Compare Measurement Results

If you intend to repeat a measurement with different settings, you may wish to preserve the current results for easier comparison. This can be done with all measurements (except Error Location Capture) by copying the results.

- 1 In the lower left-hand corner of the measurement window, select the measured terminal by tipping on it.
- 2 Select **Copy** from the **Edit** menu.

If you have a mouse connected to your Serial BERT, you can directly copy the measurement via the context menu.

- 3 Open the **Edit** menu (or context menu) once more and select **Paste**.

This inserts a copy of the chosen measurement results. For an Output Levels measurement, this looks as shown below:

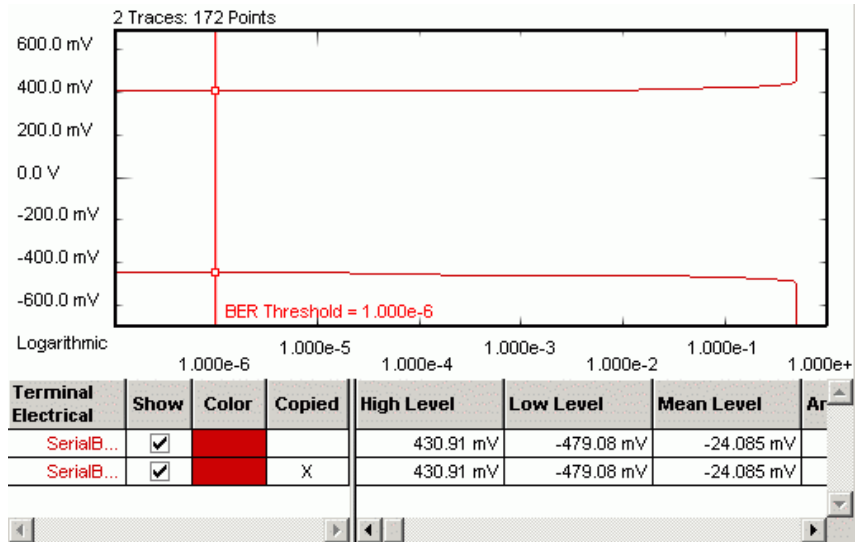

- 4 Repeat the measurement with modified parameters and observe the new results.
- 5 To distinguish the two graphs, change the color of one graph by tipping the red **Color** field.

You can now directly compare the graphical and numerical results of the two Output Levels measurements.

How to Rename Copied Measurements

To rename a copied measurement for easy distinction:

- 1 Highlight the copied measurement.
- 2 Press **Enter** (or choose **Rename** from the context menu).
- 3 Change the name and press **Enter**.

How to Load Measurements

To load previously saved measurements:

- 1 Select **Load Measurement** from the **Analysis** menu.
- 2 Use the file dialog box to locate the desired .mcp file and press **Open** to load the measurement.

The respective screen of the **Analysis** panel opens and you can view the measurement.

How to Change Measurement Properties and the Graphical Display

The various tabs in the **Properties** dialog box allow you to specify the parameters for the measurement. The available options are not the same for all measurements. See the *Reference* information of the respective measurement type for details.

To modify the measurement properties:

- 1 Press the **Properties** button to open the **Properties** dialog box.
- 2 Use the different tabs in this dialog box to make the required settings:
 - **Parameters** tab
The settings made on the **Parameters** tab define how the data is collected. If you make changes here, you need to run the measurement again.
 - **Pass/Fail** tab
On the **Pass/Fail** tab, you can specify the conditions that must be met by the DUT to pass a test. Changes here do not require a new test run. The data will be newly calculated and the results will be displayed.
 - **View** tab, **Graph** tab, and **Color** tab
With the functions on these tabs, you can modify the graphical display of the results at any time without rerunning the measurement. This allows you to analyze the results in different ways and with different preferences.
- 3 After you have made your changes on the various tabs, press **Apply** to employ the settings without leaving the **Properties** dialog box. Or press **OK** to confirm the modifications and close the **Properties** dialog box.

How to Change the Colors of the Graph

You can customize the colors of the graphical display. This function is common to all measurements:

- 1 In the **Properties** dialog box, switch to the **Colors** tab.

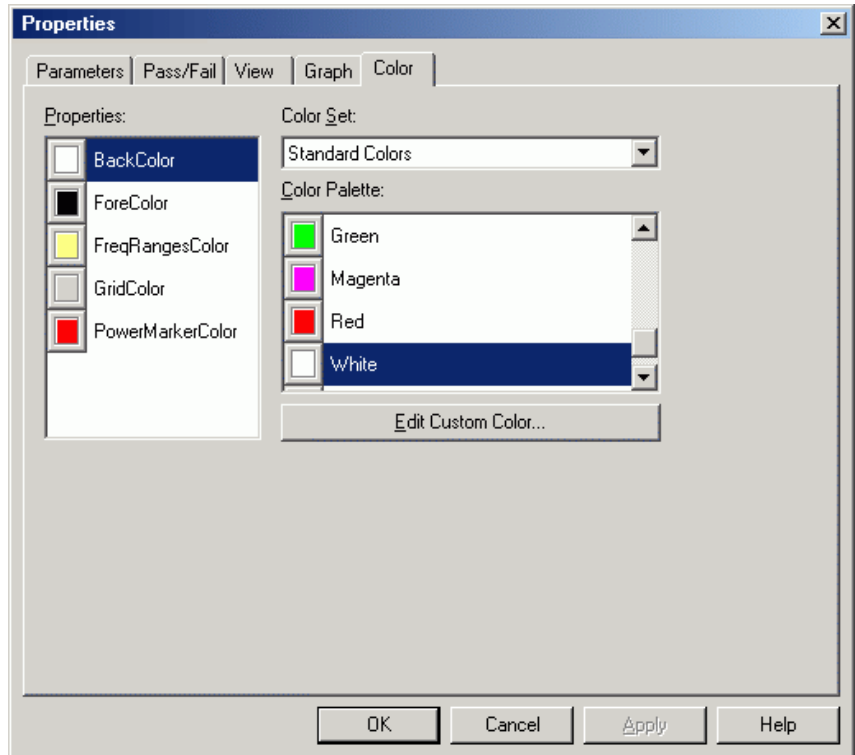

Depending on the current measurement type, you can change:

- **BackColor**: The background color of the graphs (default is white)
- **BERMarkerColor**: The color of the **BER Threshold** indicator (default is red)
- **ForeColor**: The foreground color of the scales and frame of the graphs (default is black)
- **FreqRangesColor**: Color of the selected frequency ranges (default is light yellow)
- **GridColor**: The color of the dashed grid lines (default is gray)
- **PowerMarkerColor**: The color of the **Noise Threshold** marker (default is red)

2 Select the color that you want to change from the list of used colors to the left.

3 Use the **Color Set** and the **Color Palette** to select the new color.

4 To view the results of your changes, press **Apply**.

This immediately updates the measurement window, where you can see the new colors.

5 Press **OK** to close the **Properties** dialog box.

Advanced Analysis - Reference

This section covers reference information such as definitions of important parameters and the descriptions of supplementary functions.

Exporting Result Data

If you want to use the measurement results with other applications, you can export the data to a file via **Analysis - Export Data...**

The contents of the resulting file may look as follows:

```
Date:;02/11/05 03:33:17
Version:;1.0
Type:;TM Fast Eye Mask SB-Electrical
UI:;9.6969E-011

Threshold Units:;Volts
Delay:;Relative
[1:1] SerialBERT;;;
Delay;Threshold;BER(All);

-3.878757E-011;1.504954E-001;2.497699E-001;
3.878757E-011;1.504954E-001;2.499503E-001;
-1.551503E-011;3.504954E-001;4.922570E-001;
1.551503E-011;3.504954E-001;4.952636E-001;
-1.551503E-011;-4.950459E-002;0.000000E+000;
1.551503E-011;-4.950459E-002;0.000000E+000;
; ; ;
```

This file can be imported into spreadsheet applications such as Microsoft Excel, for example. Use the semicolons as delimiters for the rows or columns.

	A	B	C	D	E
1	Date:	#####			
2	Version:	B.16.010306			
3	Type:	DUT Output Timing - Jitter			
4	UI:	2.50E-05			
5					
6	[2:1] Data0				
7	Delay	BER(All)	Compared Bits	Errors(All)	
8	3.60E-09	0.500044	1.00E+06	5.00E+05	
9	3.73E-09	0.499992	1.00E+06	5.00E+05	
10	3.85E-09	0.499947	1.00E+06	5.00E+05	
11	3.98E-09	0.500007	1.00E+06	5.00E+05	

Timing Unit Definitions

The timing unit specifies the timebase for the measurements. It is possible to switch between the unit interval (UI) or seconds for the time scale. The timebase is set on the **View** page of the **Properties** dialog box.

The following figure and table shows the relationship between UI and seconds for a 500MHz signal:

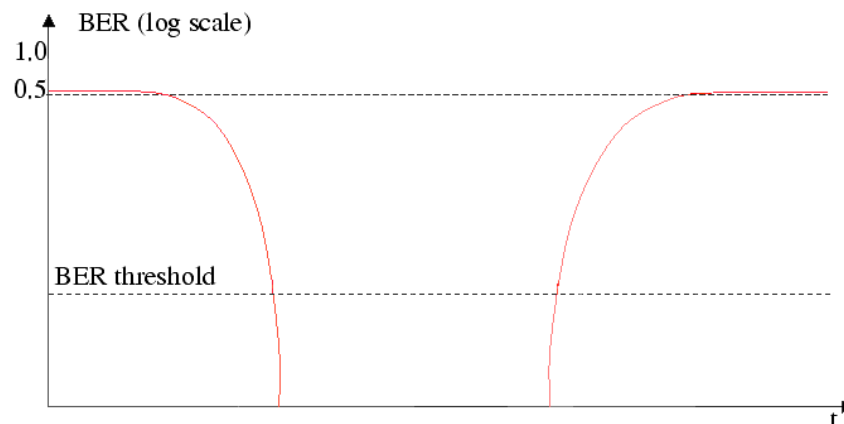

An example of the measured range of time expressed in the different units is listed below:

Table 17

Timebase		Earliest Sampling	Optimum Sampling Point	Latest Sampling
Time	rel.	-1.5 ns	0 ns	+1.5 ns
	abs.	54.2 ns	55.7 ns	57.2 ns
Unit interval	rel.	-0.75 UI	0 UI	+0.75 UI
	abs.	27.1 UI	27.85 UI	28.6 UI

The Unit Interval

Unit interval values are a convenient way to express time values in a dimensionless form. One unit interval is the equivalent of one clock period. To convert a time value to a unit interval value, divide it by the pulse period or multiply it by the clock frequency.

Example At 100MHz, the pulse period is $1/100 \times 10^{-6} \text{ s} = 10^{-8} \text{ s} = 10\text{ns}$; this is the unit interval (UI). For example, a value-in fact, any parameter that is specified in time units-of 37ns is equivalent to $37\text{ns}/10\text{ns}=3.7\text{UI}$ (time values are expressed as multiples of the unit interval).

Measurements at different frequencies This makes it easy to analyze measurements at different frequencies: If the measured phase margin is 8ns at 100MHz (1UI=10ns), and 4ns at 200MHz (1UI=5ns): The phase margin is 0.8UI in both cases, and it is immediately obvious that it does not depend on the system frequency. The same is true for the delay resolution parameter in the DUT Output Timing/Jitter and Eye Opening measurements: If you specify the delay resolution as 0.01UI, the measurement software will always measure 150 points across the bathtub, no matter what system frequency you choose (only if edge optimization is switched off, of course). However, if you specify the resolution in time, the number of measured points will change inversely proportional to the system frequency (doubling the frequency results in half the number of measured points).

Syntax Requirements

All time-related entries understand both time and unit interval notation, regardless of the UI/time selection made in the **View** tab of the **Properties** dialog box. You can enter 17s, 5ns or 0.01UI at any time. On run, the Serial BERT will automatically convert all entries to time values, using the current unit interval. So, the UI is handy if you want to set values independently from the system frequency.

All voltage-related entries understand 23mV, 0.01V, and so on.

All power-related values can be entered as 50mW, 0.04W, 6dBm, and so on.

All dimensionless quantities understand decimal notations (10000000, 0.0003, for example) and scientific/engineering notation (1e9, 1.7e-3, for example).

Marker Definitions

Markers are available for all measurements except of the Fast Eye Mask. They make the analysis and tracing of the results more comfortable. Markers can be switched on or off at any time when results are available in the graphical view. For the DUT Output Timing/Jitter measurement, the software provides two types of markers.

Linear Markers The following illustration shows the definitions for the markers and the values that can be derived from the marker position.

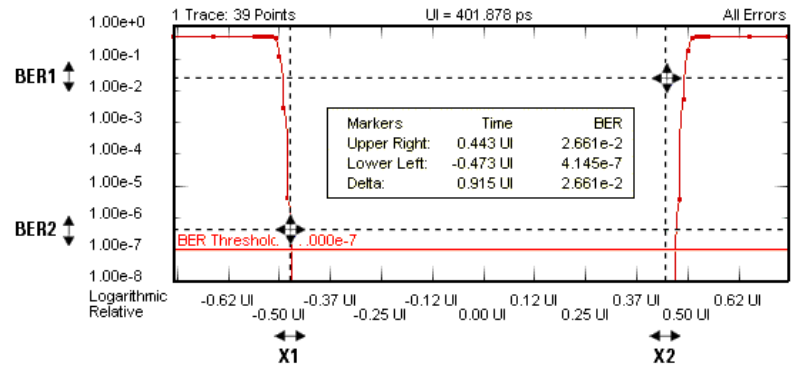

The following values are displayed for the current marker positions:

Table 18

Value	Description
Upper Right	Time and BER of the upper right intersection of the displayed marker lines (X2 and BER1)
Lower Left	Time and BER of the lower left intersection of the displayed marker lines (X1 and BER2)
Delta	Distance between the two vertical marker lines on the time axis (X2-X1) and distance of the two horizontal marker lines on the BER axis (BER1-BER2)

The markers can be moved to keep track of the data.

The Gaussian Marker A Gaussian marker is available for the following measurements:

- DUT Output Timing/Jitter measurement
- Output Levels measurement

The Gaussian marker allows to measure the normal distribution of measurement results.

The distribution of random values is called normal, if it can be described by the following formula:

$$f(x) = \frac{1}{\sigma \sqrt{2\pi}} e^{-\frac{(x-\mu)^2}{2\sigma^2}}$$

This formula describes a bell-shaped Gauss curve. If μ is zero and σ varied, you would get the curves illustrated in the figure below:

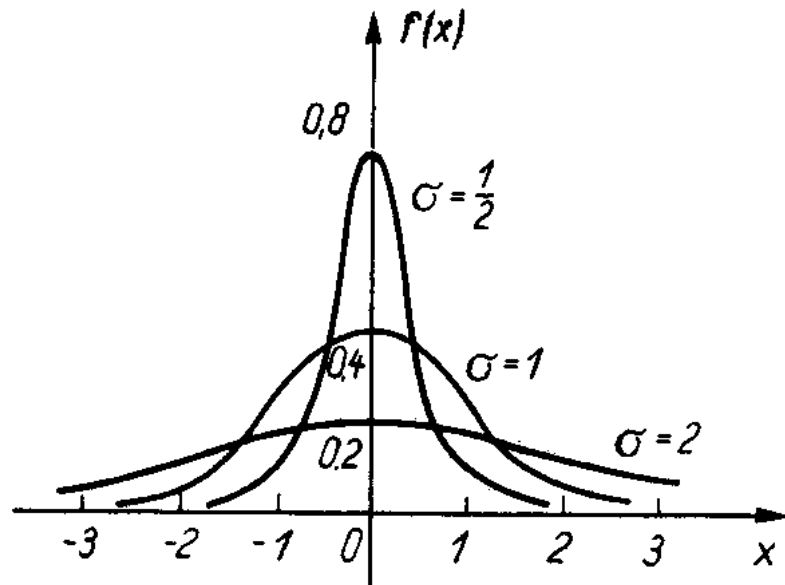

The height and position of a normal distribution can be specified in terms of two parameters: μ and σ . The parameter μ is the mean, the parameter σ is the standard deviation.

The Gaussian marker shows such a curve. Position, height, and width of this curve can be changed by dragging the handles, and the actual parameter values are displayed.

The marker has three handles that can be dragged: two for adjusting its width, one for changing its height and position.

The following figure shows an exemplary DUT Output Timing/Jitter measurement result with a Gaussian marker.

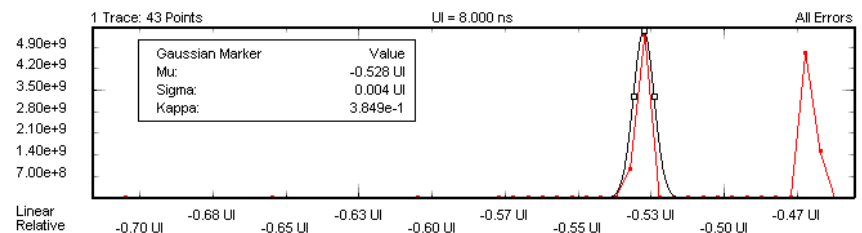

The marker readout provides the following information:

Table 19

Parameter	Symbol	Meaning
Mu	μ	Mean. DUT Output Timing/Jitter measurement: The position of the marker center on the time scale. Output Levels measurement: The position of the marker center on the vertical threshold scale.
Sigma	σ	Standard deviation. The RMS value of the marked area.
Kappa	κ	Linear scaling factor.

DUT Output Timing/Jitter Measurement

A Gaussian marker is used when the jitter graph is displayed. It is most useful if deterministic jitter is present. In this case, the jitter graph shows more than one peak (see also [“Estimated Total Jitter” on page 177](#)).

The jitter values Mean, RMS, and Peak-Peak refer to the whole jitter. The Gaussian marker allows to measure the normal distribution of individual jitter peaks. You can thus determine how parts of the jitter histogram contribute to the overall jitter values.

You may have measured a bathtub curve like the one shown below:

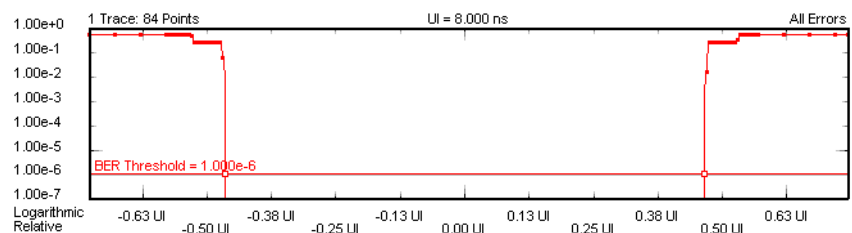

As the bathtub borders are not uniform (both have two edges), the linear derivative (the jitter) will show two peaks:

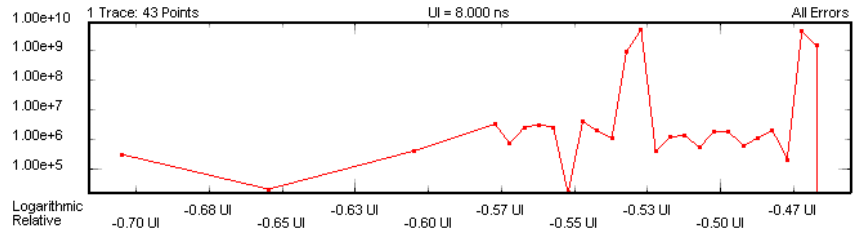

If you switch to linear scale and enable the marker, you can see its bell shape.

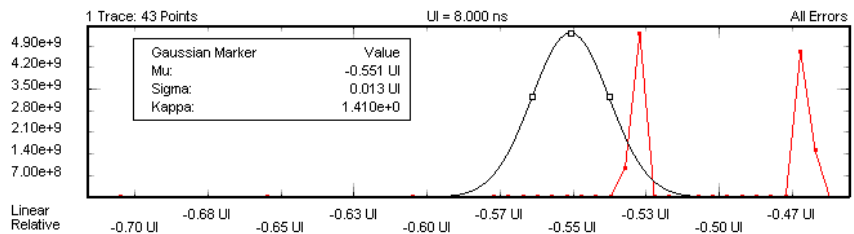

You can measure the random jitter distribution of each peak as well as the distance between the peaks, which means the deterministic jitter.

You can also use the marker with logarithmic scale. In this case, it appears as a parabolic curve:

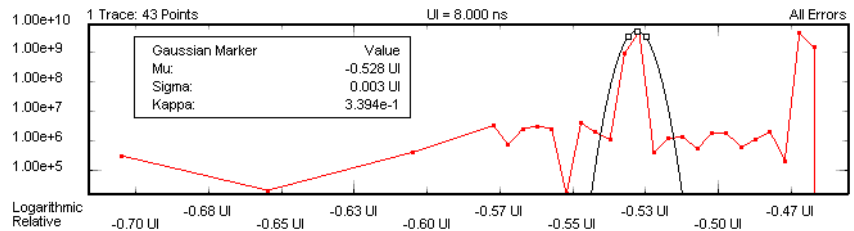

Output Levels measurement

A Gaussian marker is used when the dBER vs. Threshold Graph is displayed. This graph shows the relationship between the decision threshold and the absolute values of the derivative of the bit error rate (dBER/dTh). A linear scale reveals the distribution more clearly than a logarithmic scale (see “dBER vs. Threshold Graph” on page 207).

In the example below, μ (Mu) and σ (Sigma) will be the same as the Level and Standard Deviation results calculated by the measurement.

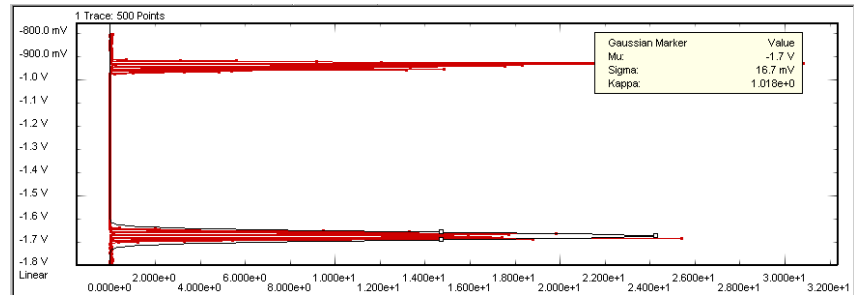

But your dBER distribution may also look like this:

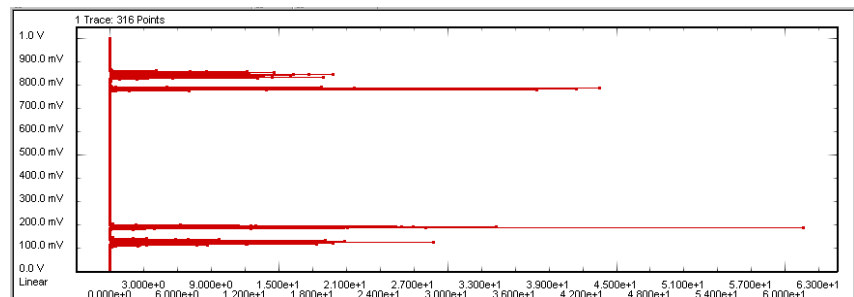

The measurement will calculate the Level and Standard Deviation results from all data points. The marker allows you to measure the μ (Mu) and σ (Sigma) of the individual peaks.

DUT Output Timing/Jitter

DUT Output Timing/Jitter - Concepts

This type of measurement is used to measure the timing and jitter behavior for a device under test (DUT). It uses a bit error rate (BER) measurement to evaluate the shape of the eye for the output signal of the DUT. It also analyzes the jitter, separates the random jitter and deterministic jitter components, and estimates the total jitter.

A direct result is the determination of the optimum sampling point delay for receiving data from the DUT with maximum confidence.

DUT Output Timing/Jitter includes the Fast Total Jitter measurement that can be used to measure the total jitter for devices which generate a very low error density in a reasonable time span.

Output Timing Characteristics

The sampling point is swept automatically within a 1.5 clock period to generate a "bathtub" curve. The resulting graph is centered around the optimum sampling point of the port.

In addition, the results are available in a tabular view. If a clock signal is defined, the software measures the data to clock alignment and displays the absolute delay.

Jitter Characteristics

The DUT Output Timing/Jitter measurement calculates the jitter histogram as the absolute of the derivative of the measured bit error rate ($\text{jitter} = d \text{ BER} / dt$).

The jitter histogram allows to separate and calculate the different components making up the jitter:

- Random Jitter (RJ)
- Deterministic Jitter (DJ)
- Estimated Total Jitter (TJ)

The peak-to-peak, RMS, and mean values are displayed in the result table. They can also be displayed graphically.

[“Jitter Measurement Parameters” on page 192](#) describes how these components are calculated.

A dedicated Gaussian marker allows to investigate the jitter graph in detail and to measure the contribution of certain sections or jitter peaks to the overall results.

You can set several signal parameters, the values to be displayed and the output format according to your needs.

Fast Total Jitter Measurement Characteristics

This measurement is an alternative to the standard jitter measurement. It can be used to measure the total jitter at very low bit error ratios.

Whereas usual jitter measurements at a BER around 10^{-12} can take days (due to the huge number of bits that has to be compared for each measurement point), the Fast Total Jitter measurement can, for example, determine the total jitter at a BER of 10^{-12} in less than 20 minutes (at a data rate of 10 Gbit/s).

For details refer to [“Explanation of the Fast Total Jitter Measurement” on page 178](#).

Example Results

The following illustration shows the resulting graph of a typical DUT Output Timing measurement:

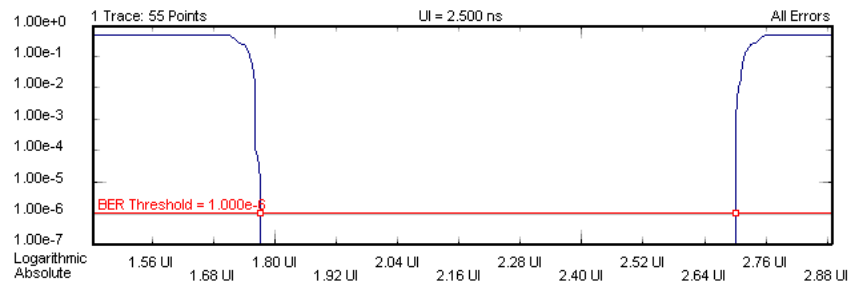

The following figure shows a typical jitter histogram with two peaks indicating the presence of random and deterministic jitter:

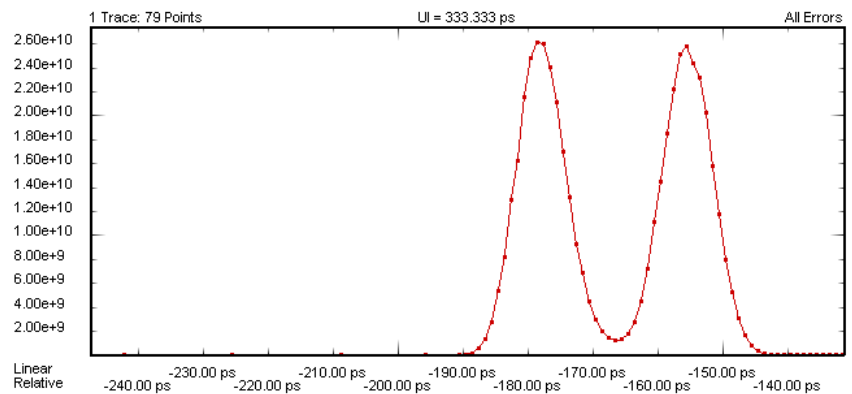

For a detailed explanation of the Fast Total Jitter measurement results see [“Explanation of the Fast Total Jitter Measurement Results”](#) on page 194.

Understanding the Jitter Calculation

After the output timing behavior of the DUT is measured, the Serial BERT calculates the different jitter components:

Random and Deterministic Jitter To understand the RJ and DJ results, it is helpful to first understand how the software generates the results:

- 1 The bathtub curve is measured.

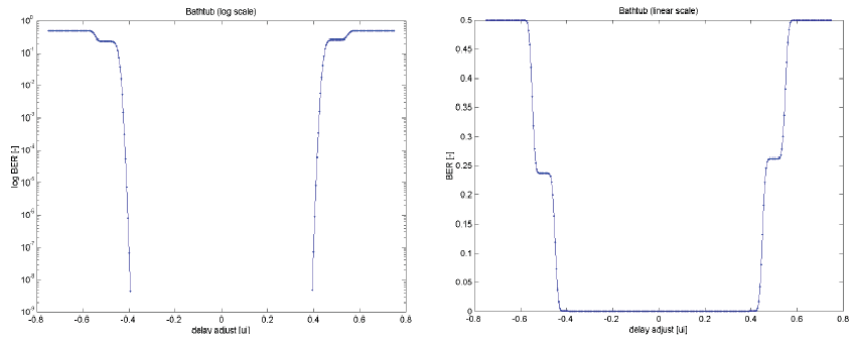

- 2 All measurement points that have BER between the **BER Threshold** and **Minimum BER for RJ/DJ Separation** are transformed into Q-space.

The Q-factor describes the signal-to-noise ratio at the decision circuit. It is described in “[Understanding the Q-Factor Results](#)” on page 216.

- 3 Linear regression is performed for both the left and right edges.

- 4 The mean and sigma are calculated for both lines:
 - RJ is calculated as the mean of the two sigmas.
 - DJ is calculated as the period minus the difference of the two means.

- 5 The estimated TJ is calculated:
 - Linear regression is used to extrapolate the bathtub curve to lower BER values.
 - The intersections of the resulting lines with the **Residual BER for RJ/DJ Separation** are located.
 - The eye opening is calculated.

The estimated TJ is the period minus the width of the eye opening.

The illustration below shows a jitter curve where both RJ and DJ are present. It also shows how the TJ peak-to-peak and RMS are calculated.

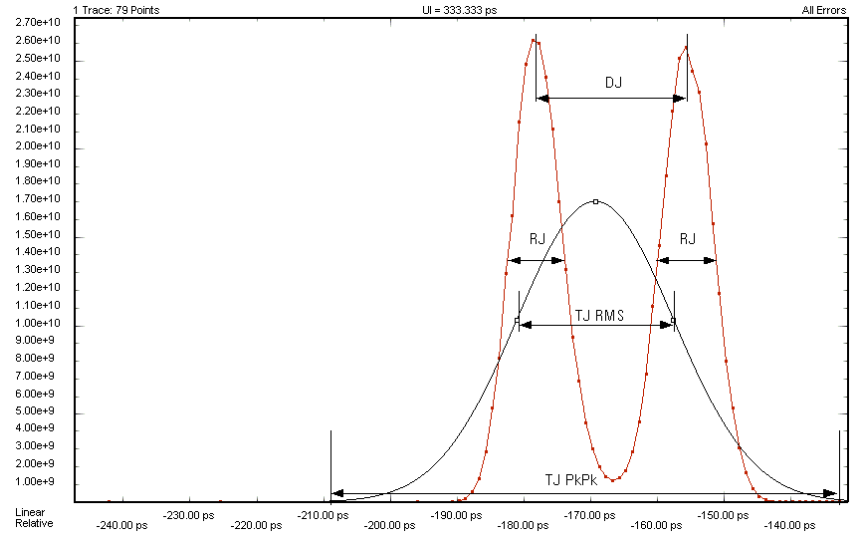

Estimated Total Jitter

The Estimated Total Jitter (TJ) allows you to predict the jitter expected for very low bit error rates that would take a long time to measure. It is obtained by extrapolating the measured BER curves.

The TJ is estimated by extending the BER curves (based on the points detected between the **BER Threshold** and the **Minimum BER for RJ/DJ Separation**) to the **Residual BER for RJ/DJ Separation** level. The estimated TJ is the period minus the width of the measured eye.

NOTE

The following graphic is not available from the measurement software. It is inserted here to show how the TJ period is calculated.

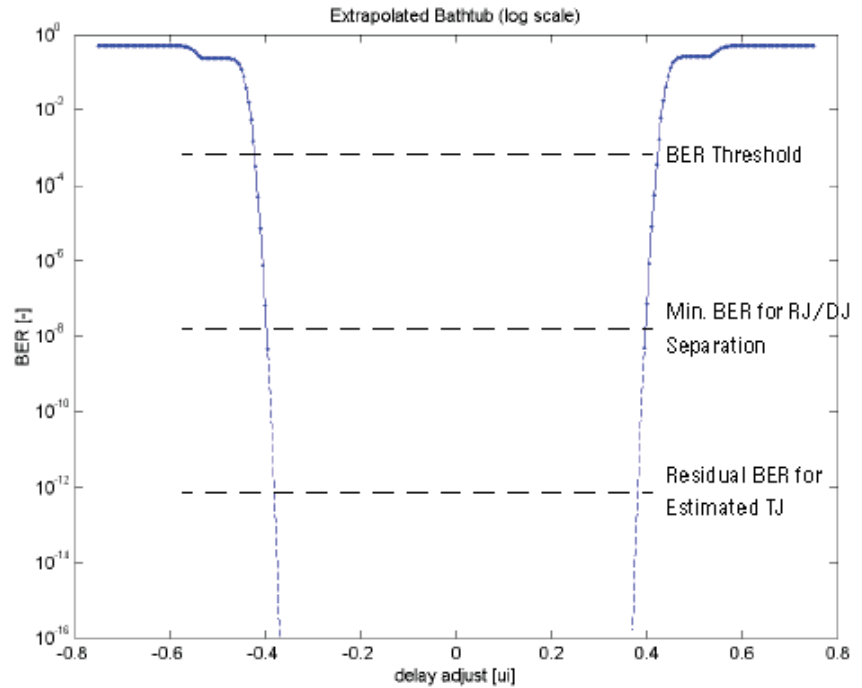

Explanation of the Fast Total Jitter Measurement

The Fast Total Jitter measurement is an optimized method to determine the total jitter for devices that generate a very low error density (BER well below 10^{-10}).

To *measure* (not estimate) the total jitter for a device with a BER of 10^{-12} with conventional methods, one usually needs to compare more than 10^{12} bits for each sample point. To measure a full eye opening this way with appropriate timely resolution takes time (maybe days or weeks, depending on the data rate), and the probability of seeing one or no error in 10^{12} bits is not higher than 37 percent.

If one would compare 10^{13} bits for the same device, the probability of seeing ten errors is even lower (12 %), but the probability of observing no error is almost zero.

The Fast Total Jitter measurement implements a method that reduces the measurement time considerably and provides a higher accuracy. It is based on statistical and probability calculations.

The method was presented at the DesignCon 2005 and is described in "**Total Jitter Measurement at Low Probability Levels, using Optimized BERT Scan Method**", included as 5989-2933EN.pdf.

We will not go into the details but provide an introduction.

The Uncertainty Band Quite often, we do not need to measure the exact BER, but can stop the measurement if we are sure that the BER is above or below a threshold. In a jitter tolerance test, for example, we need just to assure that the device under test operates with a BER better than let us say 10^{-12} ; whether the true BER is 1.1×10^{-13} or 2.7×10^{-15} is irrelevant.

To abort the measurement for a single point and proceed to the next, we need two limits that tell us whether the BER is above or below the given threshold.

These limits have been calculated from the error probability density functions applicable to BER measurements. The equations were solved for a level of confidence of 95%. The calculations have led to the following table:

Table 20

95% confidence level lower limits, BER > 10^{-12}		95% confidence level upper limits, BER < 10^{-12}	
Min number of errors	Max number of compared bits ($\times 10^{12}$)	Max number of errors	Min number of compared bits ($\times 10^{12}$)
1	0.05129	0	2.996
2	0.3554	1	4.744
3	0.8117	2	6.296
4	1.366	3	7.754
5	1.970	4	9.154
6	2.613	5	10.51
7	3.285	6	11.84

The BER threshold of 10^{-12} and hence the setting of the multiplication factor to 10^{12} is just an example-by changing the exponent, the table applies analog to other thresholds.

The following figure shows a plot of this table.

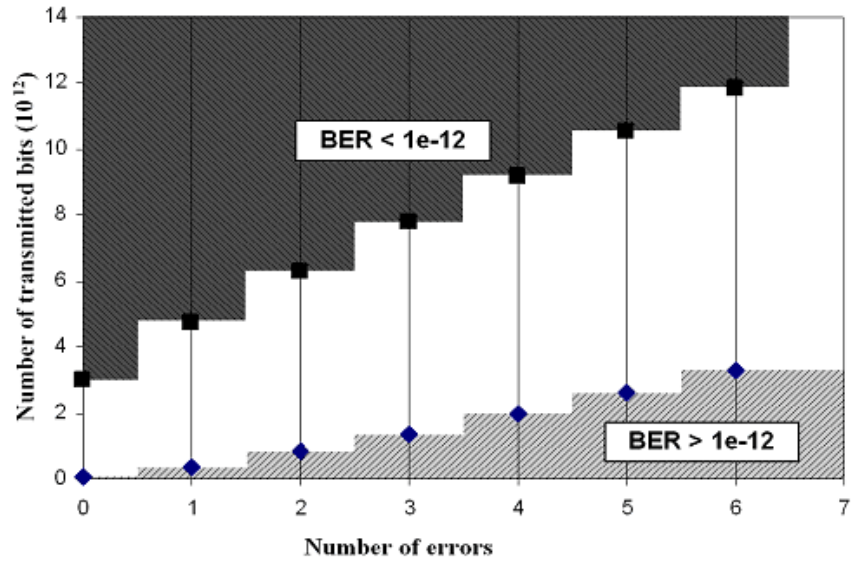

Note that there is a gap where the BER is so close to 10^{-12} that we cannot decide. For example, if we compared 3×10^{12} bits and got two errors (a measured BER of 0.667×10^{-12}), we are in the "uncertain" white area on the graph.

In such a case, we need to transmit more bits until the number of bits either reaches the upper limit (6.296×10^{12}), or until we see more errors. If the actual BER is very close to 10^{-12} , however, we are unable to apply a lower or upper limit to the BER, no matter how many bits we transmit. Whether such a test fails or passes depends entirely on the application.

The Bracketing Approach

Once we are able to decide for a measured point whether its BER is above or below the BER threshold, we can determine the total jitter at the intersection of the BER threshold with the bathtub curve.

Since we are unable to find a single point on the slope where the BER is exactly 10^{-12} , we search for an interval that brackets the point at which the BER is equal to 10^{-12} . This is illustrated for the left-hand slope in the following figure.

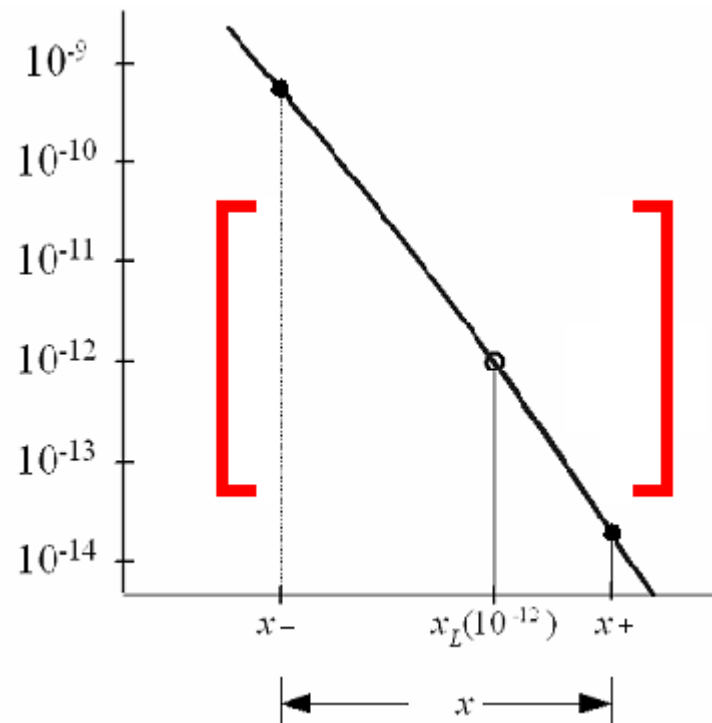

We do not need to know the exact BER values at x^+ and x^- . It is sufficient to assure that $\text{BER}(x^-)$ is greater than 10^{-12} and $\text{BER}(x^+)$ is lower than 10^{-12} at a confidence level of 95 %.

The algorithm then assumes that x_L (for the left-hand slope of the bathtub curve) is in the middle of the bracketing interval. After repeating the procedure to determine x_R (for the right-hand slope), it calculates the total jitter peak-to-peak like in the standard timing/jitter measurement.

Measurement Duration The duration of a Fast Total Jitter measurement depends on:

- the BER threshold
- the bit rate
- the sample delay step size
- the contribution of random jitter
- the contribution of deterministic jitter

Compared to a conservative bathtub measurement, the Fast Total Jitter measurement can reduce the measurement time by more than a factor of 40.

Typical test times are approximately 20 minutes at 10Gbit/s and slightly more than one hour at 2.5 Gbit/s for a measurement at the 10^{-12} BER threshold with an overall confidence level better than 90%.

DUT Output Timing/Jitter - Procedures

This section shows how to set up and use the DUT Output Timing/Jitter measurement. As an example, we measure the output timing and jitter behavior of a shielded cable.

This requires the following steps:

- Preparing the measurement (see [“How to Prepare the DUT Output Timing/Jitter Measurement”](#) on page 182)
- Executing the measurement (see [“How to Execute the DUT Output Timing/Jitter Measurement”](#) on page 183)
- Optimizing the view of the results (see [“How to Optimize the View of the Results”](#) on page 183)

How to Prepare the DUT Output Timing/Jitter Measurement

To use the DUT Output Timing/Jitter measurement to test a shielded cable:

- 1 Disable the pattern generator outputs by pressing the **0V (Disable)** button in the **PG Output Setup** screen.
- 2 Use a shielded cable to connect the pattern generator's Data Out port and the error detector's Data In port.
- 3 Terminate all non-connected pattern generator output ports with 50 Ω .
- 4 Use a shielded cable to connect the pattern generator's Data Out port and the error detector's Data In port.
- 5 Switch to the **Pattern** menu and press **Pattern Select**. Select an appropriate pattern, for example a pure 2¹⁵-1 PRBS, for both the pattern generator and the error detector.
- 6 For the pattern generator setup you need to specify the logic levels and the bit rate. Select **LVPECL** levels and **Gb Ethernet** (1.06250 G b/s) as clock speed. See [“Setting up the Pattern Generator - Concepts”](#) on page 69 for more information.
- 7 Set up the error detector so that the input range and the termination matches the pattern generator's levels:
 - Select an **Input Range** from 1V to 3V
 - Set the **Data Termination** to 1.3V
 - Set the **Clock Setup** to **Clock Data Recovery** to get the error detector's clock from the incoming data stream.

- 8 Enable the pattern generator outputs by pressing the **0V (Disable)** button.
- 9 Press **Sync Now** and then **Auto Align** to find the optimum sampling point. Check that the synchronization and the alignment were successful. None of the error indicators at the top of the user interface should show red and the resulting BER should be zero.

How to Execute the DUT Output Timing/Jitter Measurement

To run the DUT Output Timing/Jitter measurement:

- 1 Switch to the **Analysis** area. If the **Output Timing** screen is not yet displayed, press the **Output Timing** icon.
- 2 Press the **Start** button to execute the measurement.

The measurement software runs the measurement and displays the results. The following illustration shows the bathtub curve of the measured bit error rate and-in the tabular view-the calculated results for the **Optimal Sampling Delay**, the **Skew** and the **Phase Margin**.

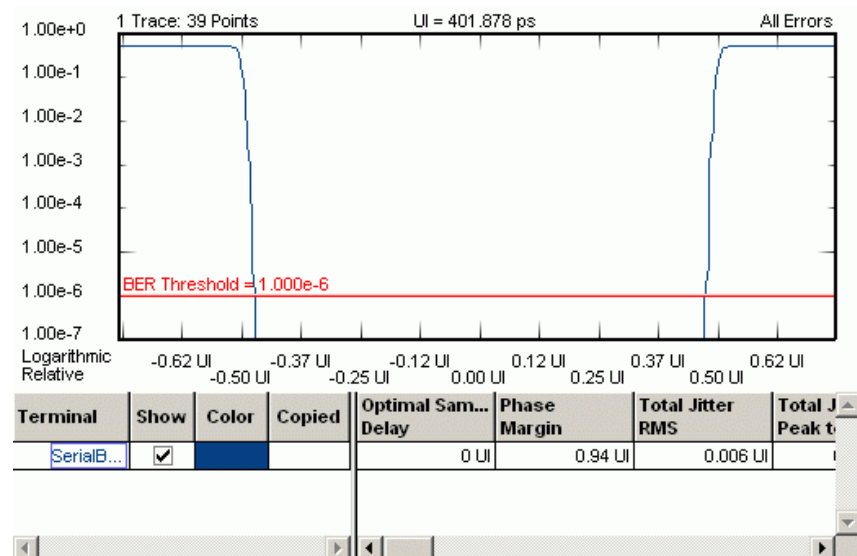

How to Optimize the View of the Results

After you have run a measurement, the resulting graph and the calculated numerical values are displayed. To improve the results, you can change the measurement parameters:

- 1 Press the **Properties** button to open the **Properties** dialog box.
- 2 Use the different tabs in this dialog box to make the required settings:

- **Parameters** tab

These settings are used for data collection. Changes here require the test to be run again. See [“Parameters Tab” on page 184](#) for details.

- **Pass/Fail** tab

These settings determine whether the calculated results are recognized as passed or failed. However, a new test run is not required when doing changes here. See [“Pass/Fail Tab” on page 186](#) for details.

- **View** tab, **Graph** tab, and **Color** tab

All settings on these tabs only affect the way the data is displayed. You do not need to run the measurement again. See [“View Tab” on page 188](#), [“Graph Tab” on page 190](#), and [“How to Change the Colors of the Graph” on page 164](#) for details.

- 3 Press **OK** when you have made all required changes to close the **Properties** dialog box.

DUT Output Timing/Jitter - Reference

The DUT Output Timing/Jitter measurement returns the results in a graphical and in a numerical form. The following sections describe the results:

- They provide explanations of the measured parameters and the display options that are specific to this measurement.
- Additionally, some information is provided to explain the theoretical background behind the jitter calculations.

TIP

You have access to the user documentation (including User's Guide) over the instrument's Start menu: Start->Programs->N4900 Series Documents.

Properties that can be specified on the various tabs of the **Properties** dialog box:

Parameters Tab

NOTE

If you modify the parameters on this page, you have to rerun the measurement to update the results.

Set the criteria for moving to the next sample point:

- **Number of Compared Bits**

After this number of compared bits, the measurement stops for the current sample point and moves to the next one.

- **Number of Errors**

After this number of errors, the measurement stops for the current sample point and moves to the next one. This allows you to speed up the measurement. You can switch off this option if only the number of compared bits is important.

NOTE

The measurement moves to the next sample point when the first of the two criteria is reached.

Both numbers are ignored if the Fast Total Jitter measurement is selected.

Set the criteria for the sample delay:

- **Resolution**

Specifies the time distance between sampling points. A smaller value yields more sampling points in a unit interval. You can enter the resolution in UI or ps, ns, s, The timebase of the display is set on the **View** tab.

If the resolution used for the measurement is not high enough, the bathtub curve does not clearly show the edges. For example, you may wish to change the **Resolution** from 0.01 to 0.005 and run the measurement again.

- **Optimization**

You can choose between **Edge Resolution Optimization**, **Fast Total Jitter at BER**, or **None**.

- **Edge Resolution Optimization**

Turns the resolution optimization on or off. If this option is enabled, the Serial BERT intelligently sets a resolution so that there are more sampling points at the edges. This can greatly improve the results without dramatically increasing the duration of the test.

The following illustration shows a diagram with default resolution and no edge resolution optimization:

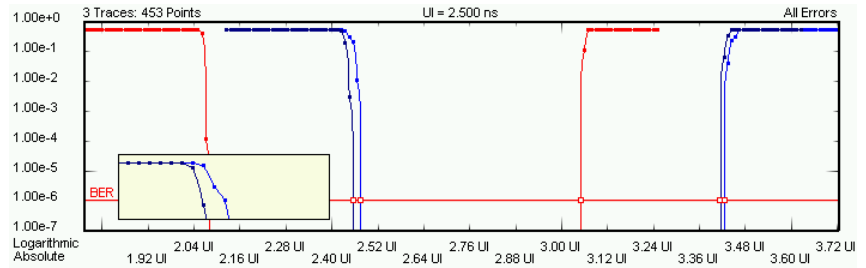

The following illustration shows a diagram with high resolution and edge resolution optimization. For the areas of the diagram with edges, additional sampling points are taken, resulting in a much better display of the signal shape:

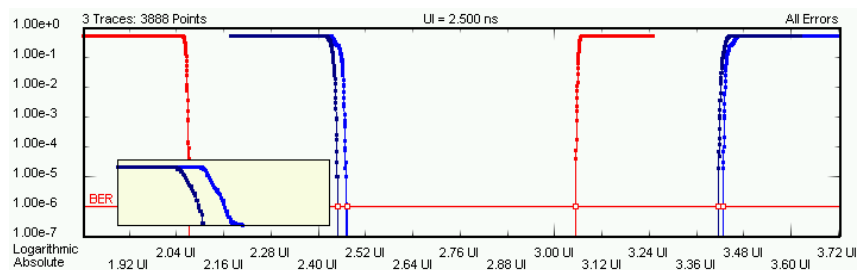

– **Fast Total Jitter at BER**

This enables the Fast Total Jitter measurement. Before enabling this measurement, you need to know the BER floor of the device and to specify a BER threshold that is above that floor. For details see [“Explanation of the Fast Total Jitter Measurement”](#) on page 178.

Pass/Fail Tab

The **Pass/Fail** tab of the **Properties** dialog box allows you to specify the criteria to decide whether the DUT passes or fails the test. You can change pass/fail criteria without rerunning a test. The software only uses the criteria to rate the results of a measurement.

NOTE

The pass/fail criteria do not control measurement execution. The measurement run will be completed even if the measurement fails for one or more of the criteria.

You can set pass/fail limits individually for the output timing parameters and the jitter measurement parameters:

- For information on the **DUT Output Pass/Fail** criteria, see also [“Output Timing Measurement Parameters”](#) on page 192.

- For information on the **Jitter Pass/Fail criteria**, see also “Jitter Measurement Parameters” on page 192.

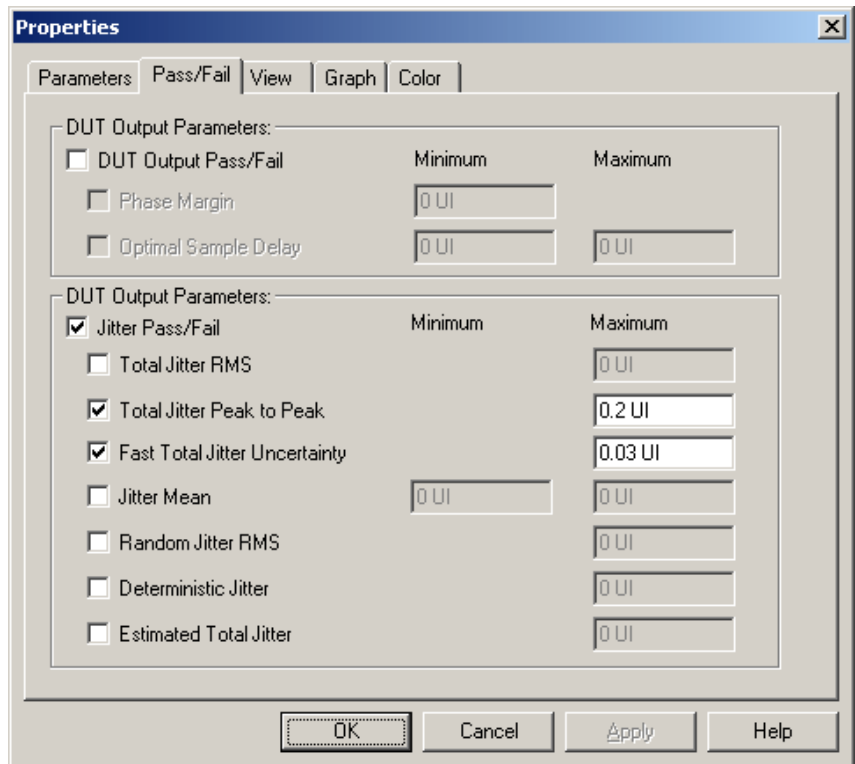
**NOTE**

If the results of a Fast Total Jitter measurement are displayed, only the appropriate parameters are compared and flagged:

- Phase Margin
- Optimal Sample Delay
- Total Jitter Peak to Peak
- Fast Total Jitter Uncertainty

Other pass/fail limits may be enabled but are ignored.

In the tabular view, each of the calculated values will be marked with an



icon if it failed the test.

The following illustration shows a DUT Output Timing/Jitter measurement that has failed the criterion for the phase margin.

5 Advanced Analysis

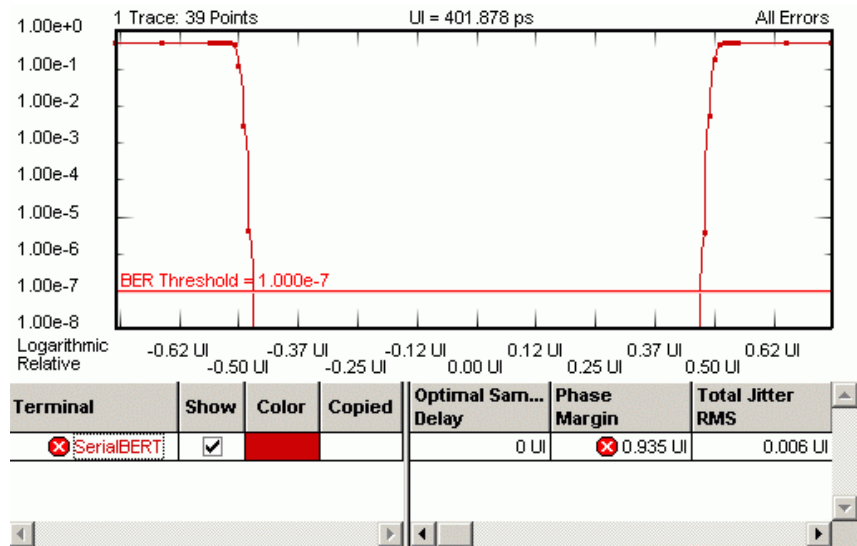

View Tab

The graph shows either the bathtub curve or the jitter distribution vs. time.

Bit Error Rate Graph The BER graph (the bathtub) shows the BER vs. sample delay.

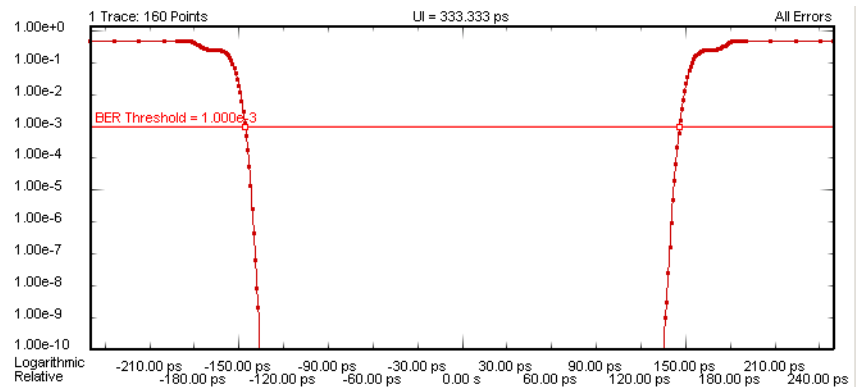

The BER graph can be viewed in either linear and logarithmic view. The logarithmic view is shown above.

Jitter Histogram The DUT Output Timing/Jitter measurement calculates the jitter histogram as the absolute of the derivative of the measured bit error rate (jitter=dBER/dt).

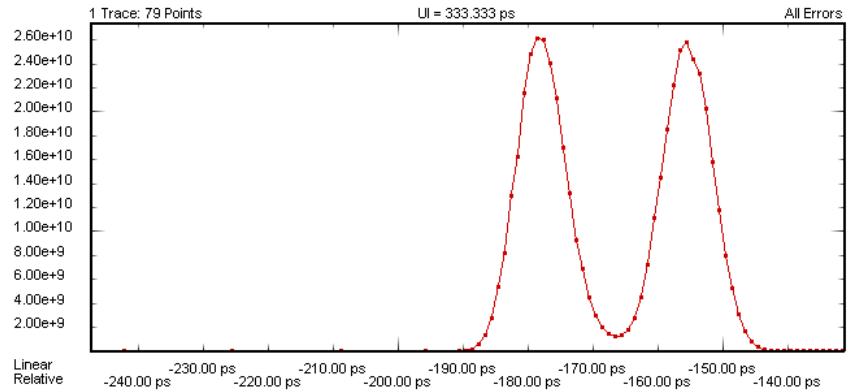
**NOTE**

Because the right-hand slope of the tub does not provide additional information on the jitter, the measurement's jitter display shows only the portion at the left-hand side of the optimum sampling point.

The jitter histogram allows you to visually inspect the jitter components:

- Random Jitter (RJ)
- Deterministic Jitter (DJ)
- Estimated Total Jitter (TJ)

“[Jitter Measurement Parameters](#)” on page 192 describes how these components are calculated.

A Gaussian marker is available in this view to help analyze the jitter components. See “[The Gaussian Marker](#)” on page 169 for details.

Furthermore, the following parameters can be set on the **View** tab of the **Properties** dialog box:

Analyze You can analyze for:

- **All Errors**
To calculate the BER values from all bits/errors.
- **Errors if 0s Expected**
To calculate the BER values if "0" is expected, but "1" received.
- **Errors if 1s Expected**
To calculate the BER values if "1" is expected, but "0" received.

Calculate You can calculate measurement parameters for:

- **0 Errors**
To calculate the parameters for 0 errors.

If this is selected, RJ/DJ separation is not available.

- **BER Threshold**

To calculate the parameters for the given BER threshold. This is the BER level for which output timing numerical values (phase margin, skew, etc.) are calculated. It is also the upper limit of the BER range for RJ/DJ separation.

The BER threshold influences some of the parameters of the DUT Output Timing measurement. You can also drag and drop the horizontal BER threshold in the graphical display to change this value.

- **Min BER for RJ/DJ Separation**

Lower limit of the BER range for RJ/DJ separation.

- **Residual BER for Estimated Total Jitter**

BER level for which the estimated total jitter is calculated. See [“Estimated Total Jitter” on page 177](#) for details on how it is used.

Table Number Format You can select the number of **Decimal Places** to be displayed in the table.

Graph Tab

On the **Graph** tab, you can use the several options to optimize the graphical display according to your needs.

Timing Units Choose between **Unit Interval** and **Seconds** to select the timebase for the display's x-axis.

Scale Choose between **Logarithmic** and **Linear** to select the scale for the display's y-axis.

For example, a DUT Output Timing measurement displayed on a linear scale may look like this:

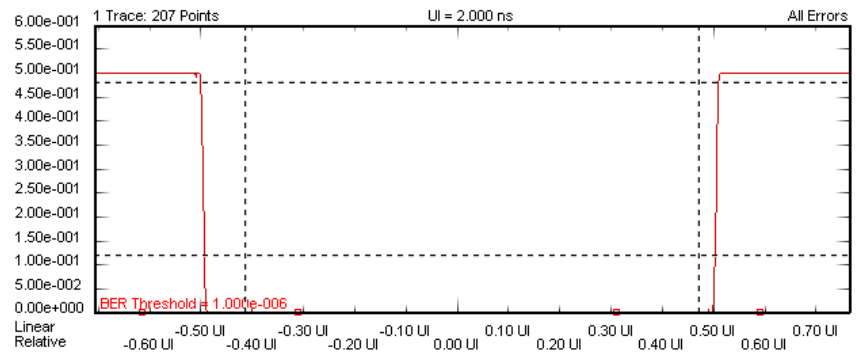

Markers To analyze the graphs at a particular point, you can use the markers. Additionally, you can display all related values for the markers in the marker readout.

Pressing the **Reset Markers** button will set the markers back to the default positions.

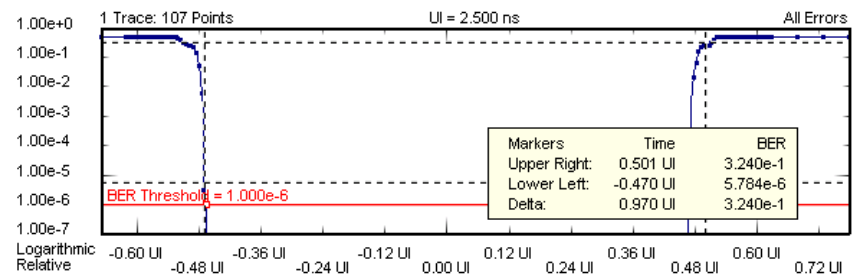

Zoom Several zoom factors are available. When you show the zoom graph, you can also allow the zoom graph to track the mouse (or your finger, if you are working directly on the Serial BERT).

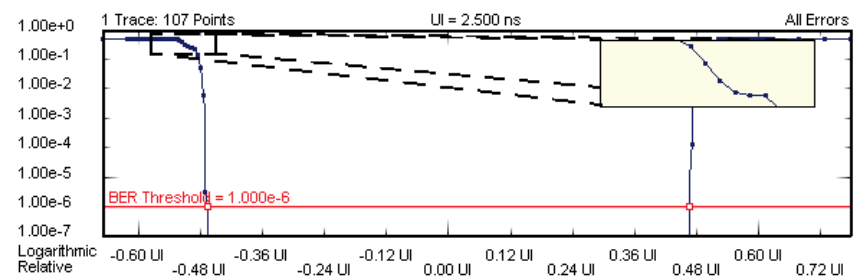

Show Measured Points If you want to see the points that have actually been measured, choose **Show Measured Points**.

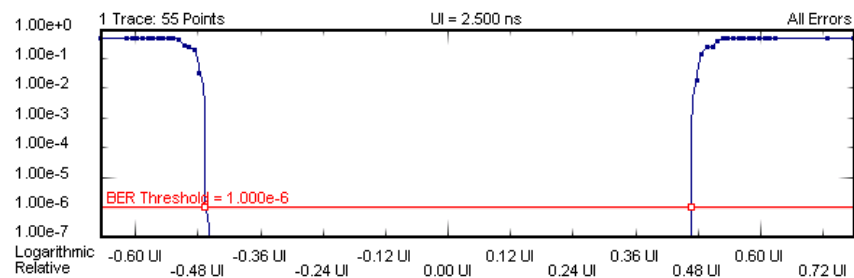

Explanation of the Numerical Results

The measurement provides numerical results for:

Output Timing Measurement Parameters

The output timing measurement parameters are defined in the following table:

Table 21

Parameter	Description	Definition
Optimal Sample Point Delay	The average of the left (A) and right (B) bathtub/BER threshold intersections.	$(A+B)/2$
Phase Margin	The period of time where the bit error rate is lower than the BER threshold.	$B-A$

The A and B values are the left and right intersections of the bathtub curves with the BER threshold. Obviously, all values change if the BER threshold is modified.

The following illustration shows an example for a measurement.

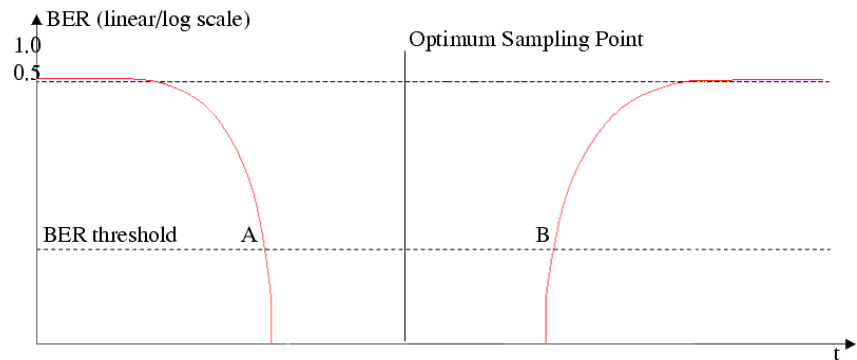

NOTE

This graphical view is not available in the measurement software.

Jitter Measurement Parameters

The jitter measurement parameters are defined in the following list.

NOTE

All jitter measurement parameters (except the Total Jitter RMS and Total Jitter Mean) change with the BER threshold.

- **Total Jitter RMS**
The average of the left and right jitter histogram root mean squared values.
- **Total Jitter Peak-to-Peak**
Peak-to-peak value for total jitter. Calculated as the pulse period (unit interval) minus the **Phase Margin**.
- **Jitter Mean**
Mean value for total jitter. Calculated as the weighted average of the left edge jitter histogram.
- **Random Jitter RMS**
The total jitter component with Gaussian distribution. After transforming a contiguous range of measured points into Q space and performing a linear regression, it is calculated as the mean of the sigmas of the two straight lines. The contiguous range is limited by the the BER Threshold and the **Min. BER for RJ/DJ Separation** threshold.
- **Deterministic Jitter**
The total jitter component with non-Gaussian distribution. After transforming a contiguous range of measured points into Q space and performing a linear regression, it is calculated as the period minus the difference between the means of the two straight lines.
- **Estimated Total Jitter**
A forecast of the expected jitter for very low bit error rates. After extrapolating the measured BER curves, it is calculated as the period minus the expected width of the eye opening.
- **No. of points**
This is the number of points that has been measured between the BER Threshold and the **Min. BER for RJ/DJ Separation** threshold. It is displayed for both slopes. This number has to be greater than 2 for the RJ, DJ, and estimated TJ values to be applicable.
- **R² values**
The R² values are calculated for both slopes of the bathtub curve. They are a measure of how well the transformed points between **BER Threshold** and **Min. BER for RJ/DJ Separation** fit to the linear regression. They have to be greater than 0.75 for the RJ, DJ, and estimated TJ values to be applicable.

Unavailable Values

Under certain circumstances, some numerical results are not available. This is indicated by **<invalid>** or **<not applicable>** in the numerical results table below the measurement graphic.

- **<invalid>** indicates that the value could not be calculated. This is the case, for example, for phase margin, when the BER threshold is set to high values and does not intersect with the bathtub curve.
- **<not applicable>** indicates that the value could be calculated, however is not shown because quality criteria are not met. This is the case, for example, for RJ/DJ results, when the r^2 value of one or both edges is <0.75 . Even though RJ/DJ values can be calculated in this case, they are not shown because confidence in the results is too low.

Explanation of the Fast Total Jitter Measurement Results

The Fast Total Jitter measurement provides both graphical and numerical results:

Explanation of the Result Display

The example below shows a copied result, and the display of measured points was enabled.

The results of the recent measurement are disabled, because they refer to a standard "bathtub" measurement that provides many more results. By actuating the **Show** indicator, you can inspect both alternatively.

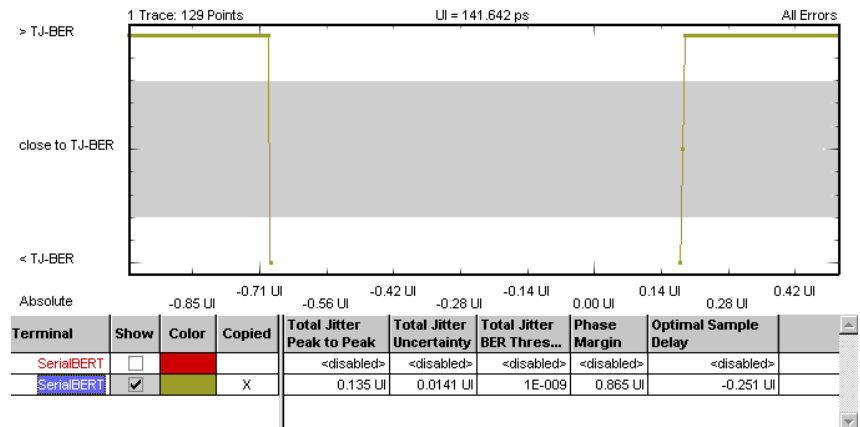

The result graph shows you the points in time that have been investigated and whether the actual BER at these points was higher or lower than the BER threshold specified for the measurement. The grey area in the middle indicates the uncertainty band (see “Explanation of the Fast Total Jitter Measurement” on page 178).

NOTE

The test will fail, if the BER floor is not well below the BER threshold specified for the measurement.

Explanation of the Numerical Results

The Fast Total Jitter measurement result parameters are summarized in the following list:

- **Phase Margin**

The period of time where the bit error rate is lower than the **Total Jitter BER Threshold**.

- **Total Jitter Peak-Peak**

Peak-to-peak value of the total jitter. Calculated as the pulse period (unit interval) minus the **Phase Margin** at the **Total Jitter BER Threshold**.

- **Total Jitter Uncertainty**

The maximum of the uncertainties of both slopes. Measured as the time between a point with a BER greater than the specified **Total Jitter BER Threshold** and the next point with a BER less than the specified **Total Jitter BER Threshold** (left slope) and vice versa (right slope).

- **Total Jitter BER Threshold**

The BER threshold specified for the measurement.

- **Optimal Sample Point Delay**

The mean value of the left and right bathtub/**Total Jitter BER Threshold** intersections.

Output Levels

Output Levels - Concepts

The Output Levels measurement allows you to characterize the behavior of the output levels of a device under test (DUT). The sampling delay is fixed. The error detector's decision threshold is automatically swept within a user-defined range.

A direct result is the determination of the optimum decision threshold level for receiving data from the DUT with maximum confidence.

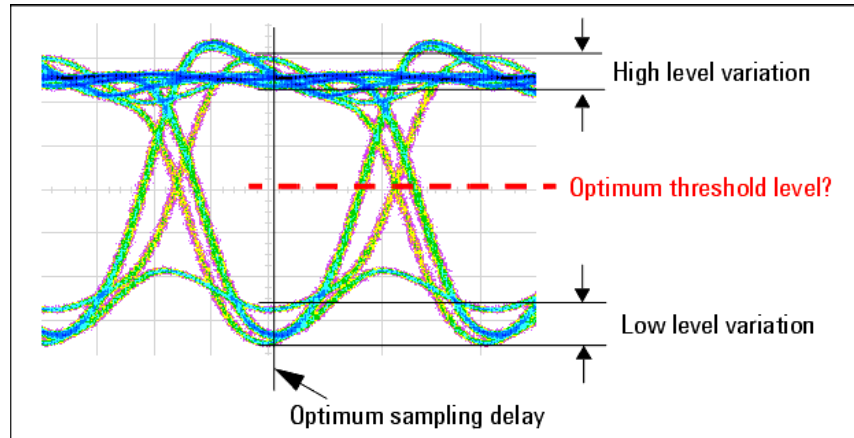

Three Available Views

The Output Levels measurement provides three different graphical views to visualize the calculated results:

- **BER versus Threshold**

This graph shows the relationship between the analyzer decision threshold and the resulting BER. It presents the raw data.

- **dB Histogram versus Threshold**

This graph shows the relationship between the analyzer decision threshold and the derivative of the bit error rate (dBER/dTh). A Gaussian marker allows you investigate the peaks of this graph.

- **Q from BER versus Threshold**

This graph shows the extrapolation of the Q-factor and the optimum threshold level from a limited number of measured points.

Example Results

The following illustration shows the **BER versus Threshold** graph of a simple Output Levels measurement:

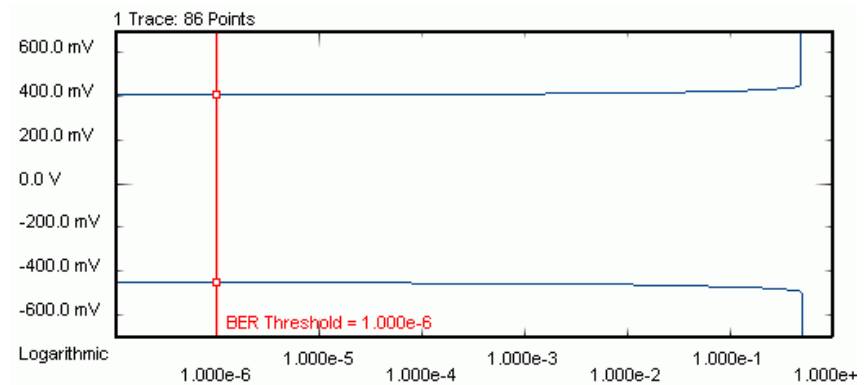

Changing Properties

If you change the measurement settings after the measurement has been run, please note:

- Parameters that affect the data capture.
 - Changes on the **Parameters** tab take only effect if you run the measurement again. To remind you that the present results have not been obtained with the modified settings and that you should repeat the measurement, the result display shows a yellow bar.
- Parameters that change the display of the measured data.
 - Changes on the **Pass/Fail**, **View**, **Graph**, and **Color** tabs only affect the display of the results. There is no need to repeat the measurement.

Variable Decision Threshold Method

The method used by this measurement is commonly known as *Variable Decision Threshold Method*. It provides a "vertical" analysis of the eye opening seen by the receiver. This method allows you to determine more than just the actual levels.

The Output Levels measurement also calculates the Q-factor (a measure that describes the quality of the received signal) and derived values. These results can assist you in characterizing the device. They can also enable you to predict very low bit error rates that would take a long time to be measured.

Output Levels - Procedures

This section shows you how to set up and perform an Output Levels measurement. As an example, we measure the output level behavior of a shielded cable.

This requires the following steps:

- Preparing the measurement (see [“How to Prepare the Output Levels Measurement”](#) on page 198)
- Executing the measurement (see [“How to Execute the Output Levels Measurement”](#) on page 199)
- Improving the Display (see [“How to Improve the Output Levels Display”](#) on page 201)
- Changing the Properties (see [“How to Change the Output Levels Properties”](#) on page 202)
- Using the different views (see [“How to Use the Different Views”](#) on page 202)

How to Prepare the Output Levels Measurement

To prepare an Output Levels measurement to test a shielded cable:

- 1 Disable the pattern generator outputs by pressing the **0V (Disable)** button in the **PG Output Setup** screen.
- 2 Use a shielded cable to connect the pattern generator's Data Out port and the error detector's Data In port.
- 3 Terminate all non-connected pattern generator output ports with 50 Ω .
- 4 Use a shielded cable to connect the pattern generator's Data Out port and the error detector's Data In port.
- 5 Switch to the **Pattern** panel and press **Pattern Select**. Select an appropriate pattern for this test. We use a pure 2²³-1 PRBS segment.
- 6 For the pattern generator setup you need to specify the logic levels and the bit rate. Select **ECL** levels and a clock speed of 1250 M Hz in this example. This corresponds to a clock period of 0.8ns. See [“Setting up the Pattern Generator - Concepts ”](#) on page 69 for more information.
- 7 Set up the error detector so that the input range and the termination matches the pattern generator's levels:
 - Select an **Input Range** from -2V to 0V

- Set the **Data Termination** to -2V
 - Set the **Alignment BER Threshold** to 1E-6.
 - Set the **Clock Setup** to **Clock Data Recovery** to get the error detector's clock from the incoming data stream.
- 8** Enable the pattern generator outputs by pressing the **0V (Disable)** button.
 - 9** Press **Sync Now** and then **Auto Align** to find the optimum sampling point. Check that the synchronization and the alignment were successful. None of the error indicators should show red.
The resulting BER should be zero.

How to Execute the Output Levels Measurement

To run the Output Levels measurement:

- 1** Switch to the **Analysis** panel and then press the **Output Levels** icon.
- 2** Press the **Properties** button to open the **Properties** dialog box.
- 3** On the **Parameters** tab, set the **Sample Threshold** parameters to suitable values that fit to the expected signal levels, for example, -1.85V to -0.85V. Set the **Resolution** to 10 mV.

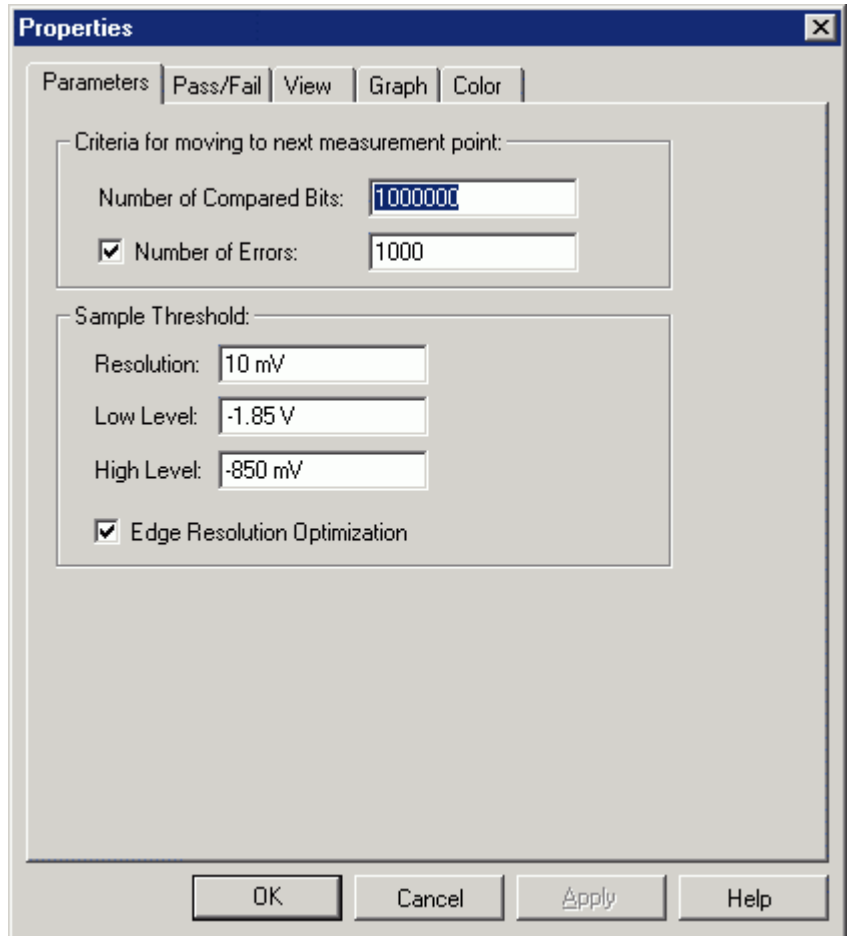

In this example, we expect the signal voltages to be between -1.75V and -0.95V. The **Sample Threshold** values proposed above cover this range well.

The **Resolution** is the distance between the measurement points when the threshold moves from the low to the high level. A resolution of 10mV results in 100 measured points per Volt.

Note that we have disabled the **Edge Resolution Optimization**.

- 4 Press **OK** to close the **Properties** dialog box.
- 5 Press the **Start** button to execute the measurement.

The measurement is run, and the result window shows the bit error rates measured at 100 threshold levels from -1.85V up to -850mV.

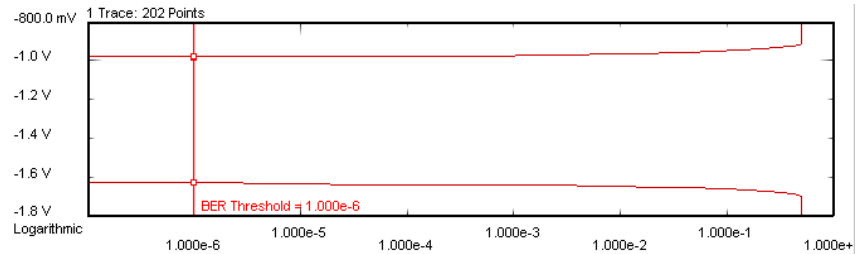

How to Improve the Output Levels Display

You can change the display of an existing measurement, for example, if you wish to see more details to investigate the graph.

This can be done on the **Graph** tab of the **Properties** dialog box:

- 1 Press the **Properties** button. If you have a mouse connected to your Serial BERT, you can also click the right mouse button on the graph and select **Properties** from the context menu.
- 2 Switch to the **Graph** tab.
- 3 As an example, select **Show Measured Points**.

With this option selected, all measured points are indicated in the graph with small squares.

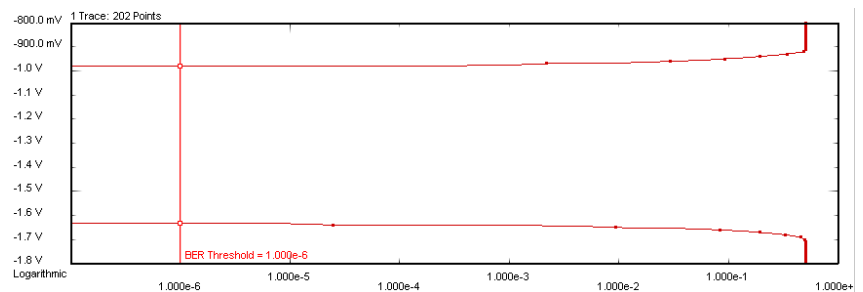

The headline of the graph tells the number of data points included in the display: 101. This corresponds to the chosen threshold resolution of 100 steps per Volt. With this number of measured points, you do not get very precise results during the measurement, but it is quickly finished.

Depending on your personal needs, you can trade measurement precision against test time.

- 4 Several more options are provided on the **Graph** tab for you to adjust the display as you want. For instance, you can use markers for analyzing the graph or open a zoom window for viewing the details. To find more information, refer to [“Graph Tab” on page 209](#).

How to Change the Output Levels Properties

In the example measurement, we have set the focus on speed: 100 threshold levels and 1,000,000 compared bits per measuring point. You may wish to obtain more precise results.

1 Press **Properties** and switch to the **Parameters** tab.

2 Increase the **Number of Compared Bits** to 100,000,000.

Remember: One failure per 1 million bits yields a BER resolution of 10^{-6} . One failure per 100 million bits yields a BER resolution of 10^{-8} .

3 Decrease the **Resolution** (the threshold step size) to 2mV.

This gives us 500 steps per Volt.

4 Press **OK** to confirm your changes.

5 Press the **Start** button to repeat the measurement with the new parameters.

The measurement now takes more time than the previous, but it is also much more precise.

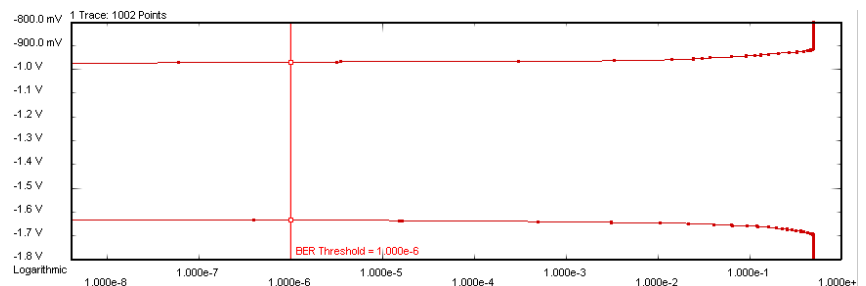

When you move the **BER Threshold** bar, you will see that some of the calculated values change. This is explained in [“Explanation of the Numerical Results”](#) on page 210.

How to Use the Different Views

To switch between the different views of the Output Levels measurement:

1 Press **Properties** and switch to the **View** tab.

2 Select **dB Histogram versus Threshold**.

This gives you another view of the measured data.

3 Switch to the **Graph** tab and select **Linear Scale**.

The data remains the same, but a linear scale makes it easier to see the distribution.

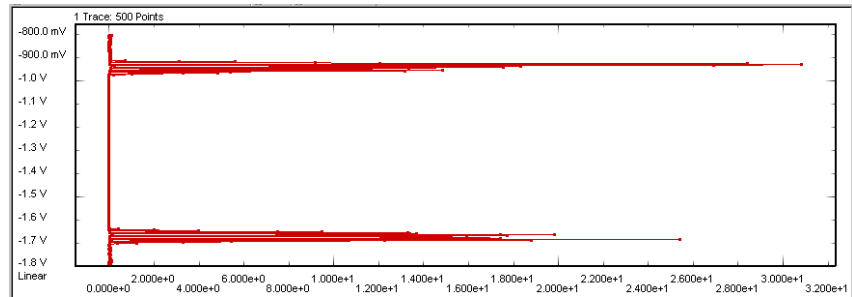

This graph shows the absolute values of the derivative of the bit error rates over the thresholds (dBER/dThreshold). It visualizes the data that forms the basis for the calculations of the level and noise values.

The graph provides a special marker that allows you to estimate the data distribution by approximating it by means of a Gaussian normal distribution.

The Output Levels measurement provides a third graphical display: the **Q from BER versus Threshold** graph. This graph refers to the Q-factor calculations. For details on these calculations see “[QBER vs. Threshold Graph](#)” on page 208 and “[Understanding the Q-Factor Results](#)” on page 216.

Output Levels - Reference

The Output Levels measurement returns the results in a graphical and in a numerical form. The following sections provide explanations of the measured parameters and the display options that are specific to this measurement. Additionally, some information is provided to explain the theoretical background behind.

The properties of the Output Levels measurement can be specified on the various tabs of the **Properties** dialog box.

Parameters Tab

NOTE

If you modify the parameters on this page, you have to rerun the measurement to update the results.

Set the criteria for moving to the next sample point:

- **Number of Compared Bits**

After this number of compared bits, the measurement stops for the current sample point and moves to the next one.

- **Number of Errors**

After this number of errors, the measurement stops for the current sample point and moves to the next one. This allows you to speed up the measurement. You can switch off this option if only the number of compared bits is important.

NOTE

The measurement moves to the next sample point when the first of the two criteria is reached.

Set the criteria for the sample threshold:

- **Resolution**

Specifies the distance between the sampling points. The lower this value is, the more sampling points you have in the selected voltage range. The minimum step width is hardware-dependent. At the time being, the minimum is 1 mV.

- **Low Level**

This is the lower end of the measured voltage range.

- **High Level**

This is the upper end of the measured voltage range.

- **Edge Resolution Optimization**

Turns the resolution optimization on or off. If this option is enabled, the Serial BERT intelligently sets a resolution so that there are more sampling points at the edges. This can greatly improve the results without dramatically increasing the duration of the test.

In the following example, a step width of 2 mV was used. This has led to 502 data points per Volt.

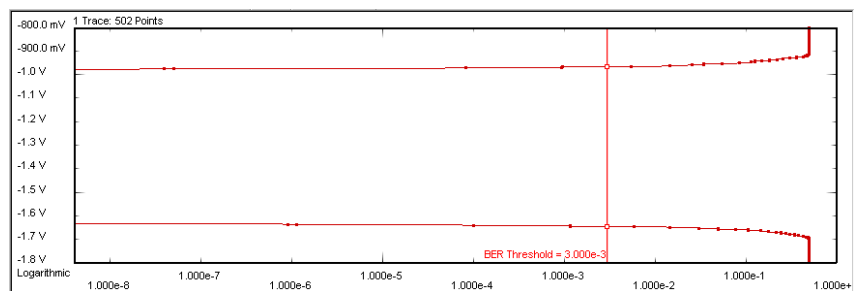

If **Edge Resolution Optimization** is enabled, the software first scans the threshold range in relatively coarse steps and determines the areas where the signal produces no edges—that means, where the BER is nearly constant.

Then, the algorithm uses the specified step width for measuring the regions where the BER changes, and a much lower resolution (about one tenth) for measuring the regions where the BER is constant.

This reduces the number of data points to 145, as shown in the figure below.

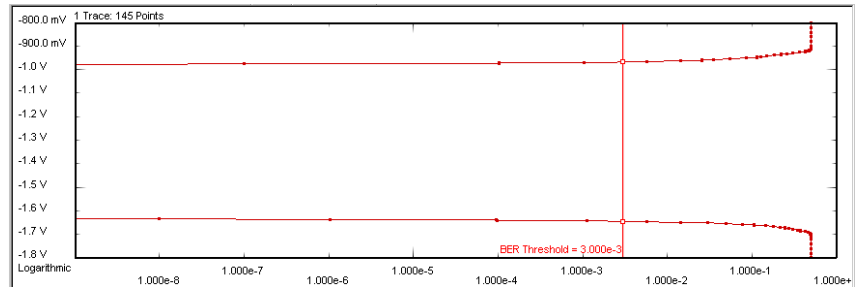

As you can see from the figures above, **Edge Resolution Optimization** does not sacrifice the precision of the measurement. But it can reduce the measurement duration considerably, especially if you compare a large number of bits at a low data rate.

Pass/Fail Tab

The **Pass/Fail** tab of the **Properties** dialog box allows you to specify the criteria to decide whether the DUT passes or fails the test. You can change pass/fail criteria without rerunning a test. The software only uses the criteria to rate the results of a measurement.

NOTE

The pass/fail criteria do not control measurement execution. The measurement run will be completed even if the measurement fails for one or more of the criteria.

You can set pass/fail limits individually for level, noise, and Q-factor parameters.

- To set the **Level Pass/Fail** criteria, see also [“Level Results” on page 210](#).
- To set the **Signal/Noise Pass/Fail** criteria, see also [“Noise Results” on page 211](#).
- To set the **Q Factor Pass/Fail** criteria, see also [“Q-factor Results” on page 212](#).

Your setup may finally look as shown below:

5 Advanced Analysis

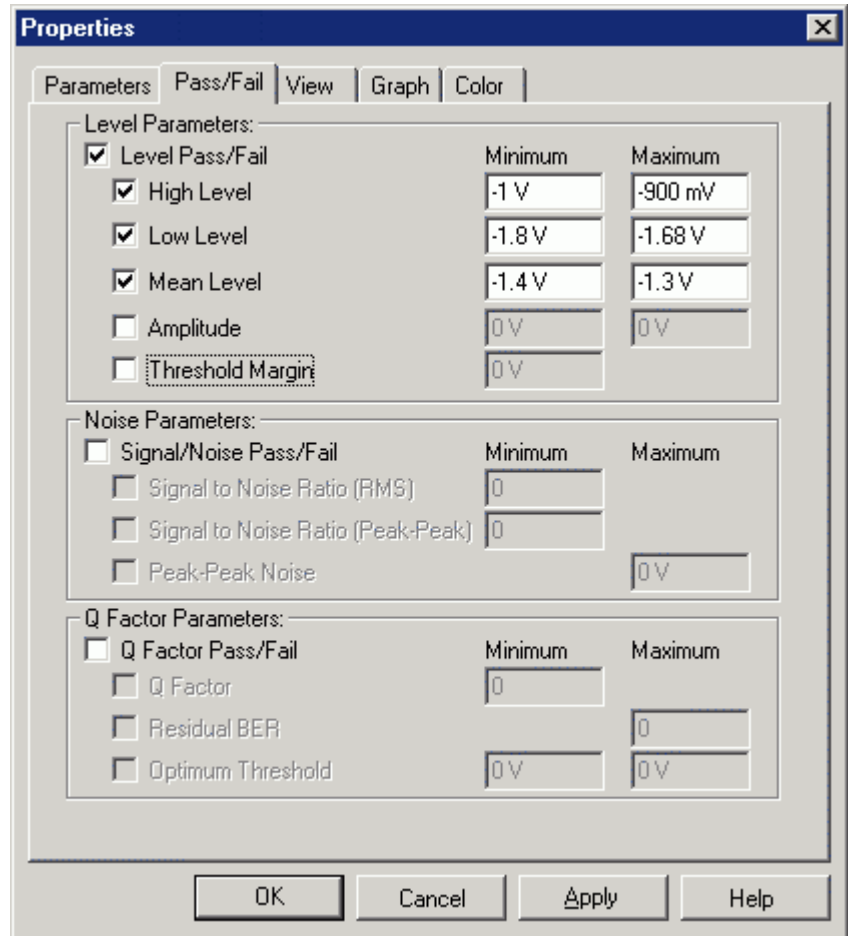

In the following figure, you can see how errors are flagged.

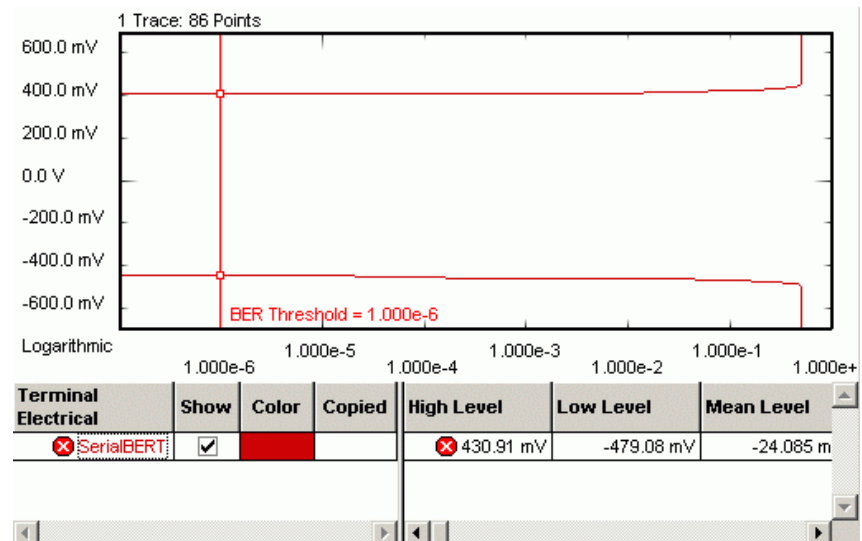

If you compare the **Low Level** result with the limit we have set on the **Pass/Fail** tab, you will find that the measured result fails the upper pass/fail limit for this parameter.

View Tab

The graph shows either the **BER vs. Threshold**, the **dBER vs. Threshold**, or the **QBER vs. Threshold**.

BER vs. Threshold Graph This graph shows the relationship between the analyzer decision threshold and the measured BER.

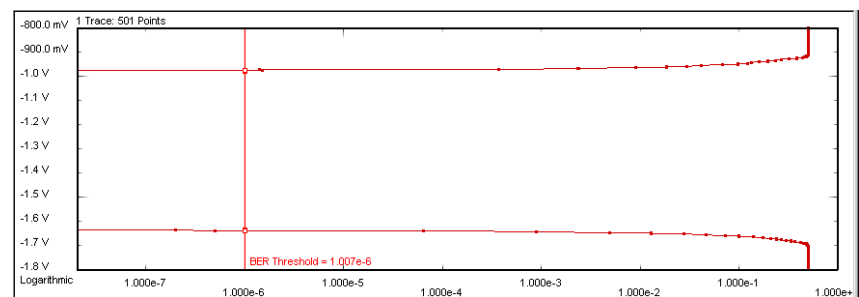

The BER considers all errors. It is calculated as:

$$BER_{AllErrors} = \frac{(\sum Error1s + \sum Error0s)}{(total \# \text{ of Bits})}$$

dBER vs. Threshold Graph This graph shows the relationship between the analyzer decision threshold and the absolute values of the derivative of the bit error rate (dBER/dTh).

It is recommended to view this graph with a linear scale because a linear scale reveals the distribution more clearly:

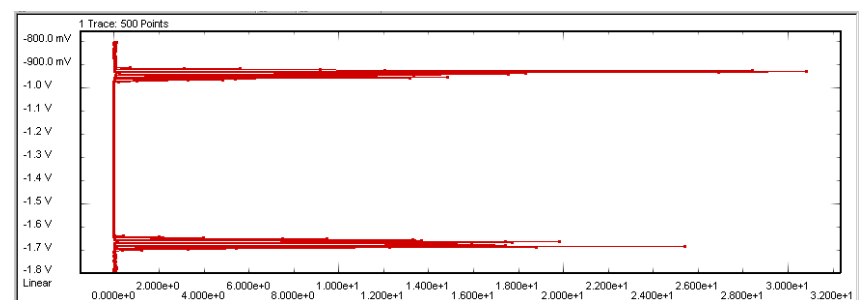

This distribution can often be approximated by a Gaussian normal distribution. With a Gaussian marker you can measure the mean and standard deviation of the normal distribution (see also [“The Gaussian Marker”](#) on page 169 and [“Graph Tab”](#) on page 209).

QBER vs. Threshold Graph This graph shows the extrapolation of the optimum Q-factor and the optimum threshold level from a limited number of measured points.

The measured data points to be used for the calculation have to be within a contiguous BER range. This range is defined by specifying the **Min BER for Q** (lower threshold) and the **BER Threshold** (upper threshold). Both thresholds can be set in the lower section of the **View** tab.

The Q-factor can only be calculated if for both high and low lever rails two or more points fall within the defined BER range. For reliable results use at least five measured points.

To ensure proper settings, activate the **Show Measured Points** function on the **Graph** tab and switch to the **BER vs. Threshold** graph. Move the upper BER threshold marker (vertical line) so that a sufficient number of measured points is included for the calculation:

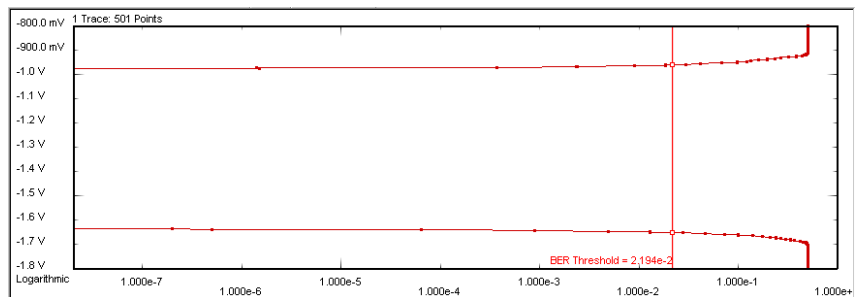

From these points, the following **QBER vs. Threshold** graph is generated:

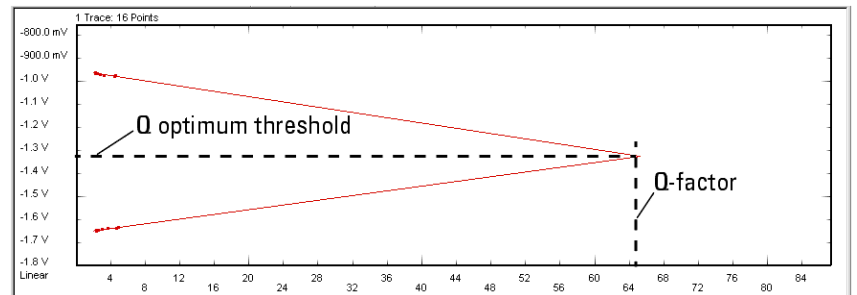

This graph illustrates the calculation of the **Q-factor** (65 in the figure above) as the best fit line through the calculated points. This method makes the calculation reproducible. For details see [“Q-factor Results” on page 212](#).

Furthermore, the following parameters can be set on the **View** tab of the **Properties** dialog box:

- Calculate** You can calculate measurement parameters for:
- **BER Threshold**

This is the bit error rate threshold at which the **Threshold Margin** is determined. It is also the upper threshold for the Q-factor calculations.

The **BER Threshold** is displayed in the **BER vs. Threshold** graph. There, it can be positioned with the mouse (or your finger, if you are working directly on the Serial BERT).

- **Min BER for Q**

This is the lower threshold for the Q-factor calculations.

Table Number Format You can select the number of **Decimal Places** to be displayed in the table.

Graph Tab

On the **Graph** tab, you can use the several options to optimize the graphical display according to your needs.

Scale Choose between **Logarithmic** and **Linear** to select the scale for the display's x-axis.

The scale of the **QBER vs. Threshold** graph is always linear.

Ratio Unit Ratios in the numerical results (such as SNR) can be displayed linearly or logarithmically in dB.

Markers To analyze the graphs at a particular point, you can use the markers. Optionally, you can display all related values for the markers in the marker readout.

Pressing the **Reset Markers** button will set the markers back to the default positions.

Linear markers are available for the **BER vs. Threshold** graph and the **QBER vs. Threshold** graph. A gaussian marker is available for the **dBER vs. Threshold** graph. See [“Marker Definitions” on page 168](#) for details.

Zoom Several zoom factors are available. When you show the zoom graph, you can also allow the zoom graph to track the mouse (or your finger, if you are working directly on the Serial BERT).

Show Measured Points If you want to see the points that have actually been measured, choose **Show Measured Points**.

NOTE

If you have a mouse connected to your Serial BERT, you can access many parameters and display options conveniently from the context menu. This looks as shown below:

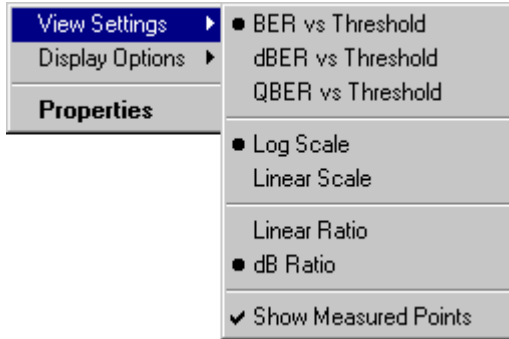

Explanation of the Numerical Results

The result parameters are divided into three groups:

Level Results The level result parameters are summarized in the following table:

Table 22

Parameter Name	Pass/Fail
High Level	min/max
Low Level	min/max
Mean Level	min/max
Amplitude	min/max
Threshold Margin	min

For all parameters, pass/fail limits can be set, as indicated in the table.

The level parameters are defined as follows:

- **High Level**

The High Level is the mean of the upper dBER/dTh distribution. It is calculated as:

$$Mean = \frac{\sum (dBer \cdot threshold)}{\sum dBer}$$

- **Low Level**

The Low Level is the mean of the lower dBER/dTh distribution. It is calculated as:

$$Mean = \frac{\sum (dBer \cdot threshold)}{\sum dBer}$$

- **Mean Level**

The Mean Level is the middle between the High and Low Levels, calculated as:

$$Mean Level = \frac{LowLevel + HighLevel}{2}$$

- **Amplitude**

The Amplitude is the difference between its High and Low Levels.

- **Threshold Margin**

The Threshold Margin is the distance between the upper and the lower BER curves at the position given by the BER Threshold setting.

Noise Results The noise result parameters are summarized in the following table:

Table 23

Parameter Name	Pass/Fail
High Level Std. Dev	
Low Level Std. Dev	
Peak Peak Noise	max
Signal/Noise Ratio (RMS)	min
Signal/Noise Ratio (Peak Peak)	min

For some of these parameters, pass/fail limits can be set, as indicated in the table.

The noise parameters are defined as follows:

- **High Level Std. Dev.**

The standard deviations are derived from the dBER/dTh histogram.

The High Level Standard Deviation is calculated as:

$$StdDev = \sqrt{\frac{\sum ((threshold - Mean)^2 \cdot dBer)}{\sum dBer}}$$

where *Mean* is the High Level of the terminal.

- **Low Level Std. Dev.**

The Low Level Standard Deviation is calculated as:

$$StdDev = \sqrt{\frac{\sum ((threshold - Mean)^2 \cdot dBer)}{\sum dBer}}$$

where *Mean* is the Low Level of the terminal.

- **Peak Peak Noise**

The peak-to-peak Noise is calculated as:

$$PeakPeakNoise = HighLevel - LowLevel - ThresholdMargin$$

Note that the Threshold Margin depends on the position of the **BER Threshold**.

- **Signal/Noise Ratio (RMS)**

The RMS Signal-to-Noise Ratio is calculated as:

$$SNR (RMS) = \frac{HighLevel - LowLevel}{StdDev_1 + StdDev_0}$$

- **Signal/Noise Ratio (Peak Peak)**

The peak-to-peak Signal-to-Noise Ratio is calculated as

$$SNR (PeakPeak) = \frac{HighLevel - LowLevel}{PeakPeakNoise}$$

Note that the Peak Peak Noise depends on the position of the **BER Threshold**.

Q-factor Results The Q-factor result parameters are summarized in the following table:

Table 24

Parameter Name	Pass/Fail
Q Factor	min
Q Optimum Threshold	min/max
Q Residual BER	max

Table 24

Parameter Name	Pass/Fail
Q High Level	
Q High Level Std.Dev	
Q High Level Nr. Points	
Q High Level R ²	
Q Low Level	
Q Low Level Std.Dev	
Q Low Level Nr. Points	
Q Low Level R ²	

For some of these parameters, pass/fail limits can be set, as indicated in the table.

The numerical Q-factor parameters are defined as follows:

- **Q Factor**

The Q-factor is calculated as:

$$Q = \frac{\mu_1 - \mu_0}{\sigma_1 + \sigma_0}$$

where $\mu_{1,0}$ is the mean level of the 1 and 0 rails, respectively, and $\sigma_{1,0}$ is the standard deviation of the noise distribution on the 1 and 0 rails.

- **Q Optimum Threshold**

The Q Optimum Decision Threshold is calculated as:

$$\text{Optimum Decision Threshold} = \frac{\sigma_0 \mu_1 + \sigma_1 \mu_0}{\sigma_1 + \sigma_0}$$

- **Q Residual BER**

The Q Residual BER is the expected BER at the Optimum Decision Threshold. It is calculated as:

$$BER = \frac{e^{-(Q^2/2)}}{Q_{opt}\sqrt{2\pi}}$$

Numbers below 1e-255 are expressed as zero.

- **Q High Level**

The Q High Level is the mean, calculated from the linear regression curve for the high level data:

$$\mu = \frac{-A}{B}$$

- **Q High Level Std.Dev**

The Q High Level Standard Deviation is the σ (Sigma), calculated from the linear regression curve for the high level data:

$$\sigma = \left| -\frac{1}{B} \right|$$

- **Q High Level Nr. Points**

This is the number of data points used for the calculation of the Q High Level value. It depends on the setting of the **BER Threshold** and also on the setting of the **Min BER for Q** parameter.

The minimum for calculating Q-factor values is two points. It is recommended to use more than 5 points.

- **Q High Level R²**

The R² parameter is an indicator that shows how well the converted data points fit to the straight line. It is calculated as:

$$R^2 = \frac{\left(\sum XY - \frac{(\sum X)(\sum Y)}{n} \right)^2}{\left(\sum X^2 - \frac{(\sum X)^2}{n} \right) \left(\sum Y^2 - \frac{(\sum Y)^2}{n} \right)}$$

The R² parameter should be examined before trusting the Q-values. Its maximum value is 1.0. It must be seen in conjunction with the number of data points.

For example: Two data points always fit perfectly well, but the resulting Q-factor calculations are not reliable. On the other hand, 50 data points may reveal a poor R² value. This tells you that the linearization is prone to errors.

If the R^2 value falls below 0.75, the Q-factor calculations are not applicable.

- **Q Low Level**

The Q Low Level is the mean, calculated from the linear regression curve for the low level data:

$$\mu = \frac{-A}{B}$$

- **Q Low Level Std.Dev**

The Q Low Level Standard Deviation is the σ (Sigma), calculated from the linear regression curve for the low level data:

$$\sigma = \left| -\frac{1}{B} \right|$$

- **Q Low Level Nr. Points**

This is the number of data points used for the calculation of the Q Low Level value. It depends on the setting of the **BER Threshold** and also on the setting of the **Min BER for Q** parameter.

The minimum for calculating Q-factor values is two points. It is recommended to include more than 5 points.

- **Q Low Level R²**

See the definition of "Q High Level R²".

Unavailable Values

Under certain circumstances, some numerical results are not available. This is indicated by **<invalid>** or **<not applicable>** in the numerical results table below the measurement graphic.

- **<invalid>** indicates that the value could not be calculated. This is the case, for example, for phase margin, when the BER threshold is set to high values and does not intersect with the bathtub curve.
- **<not applicable>** indicates that the value could be calculated, however is not shown because quality criteria are not met. This is the case, for example, for RJ/DJ results, when the r^2 value of one or both edges is <0.75 . Even though RJ/DJ values can be calculated in this case, they are not shown because confidence in the results is too low.

Understanding the Q-Factor Results

The variable decision threshold method used by the Output Levels measurement makes it possible to determine the Q-factor of a signal.

NOTE

The Q-factor method and the related calculations have been published under *Margin Measurements in Optical Amplifier Systems* by Neal S. Bergano, F. W. Kerfoot, and C. R. Davidson in IEEE Photonics Technology Letters, Vol. 5, No. 3, March 1993.

Mathematical Background

Bit errors are caused by noise, and the Q-factor describes the signal-to-noise ratio at the decision circuit.

It is possible to calculate the Q-factor from a limited number of measured BER vs. threshold data points. It is also possible to calculate expected bit error rates from the Q-factor. This is a method for predicting very low bit error rates (typically below 10^{-11}) that would take a long time to measure.

The Q-factor is calculated as:

$$Q = \frac{\mu_1 - \mu_0}{\sigma_1 + \sigma_0}$$

where $\mu_{1,0}$ is the mean level of the 1 and 0 rails, respectively, and $\sigma_{1,0}$ is the standard deviation of the noise distribution on the 1 and 0 rails.

The $\mu_{1,0}$ and $\sigma_{1,0}$ values are calculated from a selected range of data points. This calculation is correct if the noise distribution has Gaussian characteristics. Then, the bit error rate can be expressed as:

$$\text{BER}(D) = \frac{1}{2} \left\{ \text{erfc} \left(\frac{|\mu_1 - D|}{\sigma_1} \right) + \text{erfc} \left(\frac{|\mu_0 - D|}{\sigma_0} \right) \right\}$$

where D is the decision threshold, $\mu_{1,0}$ and $\sigma_{1,0}$ are the mean and standard deviation of the 1 and 0 rails, and $\text{erfc}(x)$ is the complementary error function.

This formula is the sum of two terms. It considers the probabilities of deciding that a "0" has been received when a "1" was sent, and that a "1" has been received when a "0" was sent.

For the following calculations, the assumption is made that the BER is dominated by only one of the terms noted above, depending on whether the threshold is closer to the 1 or 0 rail.

For the complementary error function

$$\operatorname{erfc}(x) = \frac{1}{\sqrt{2\pi}} \int_x^{\infty} e^{-\beta^2/2} d\beta \approx \frac{1}{x\sqrt{2\pi}} e^{-x^2/2}$$

an inverse logarithmic approximation exists:

$$\left[\operatorname{Log} \left\{ \frac{1}{2} \operatorname{erfc}(x) \right\} \right]^{-1} \approx 1.192 - 0.6681x - 0.0162x^2$$

where $x = \operatorname{Log}(\operatorname{BER})$.

This function, applied to the high level and low level data points, yields new threshold vs. value combinations.

In the area of low BER (typically below 10^{-4}), these new data pairs should fit to two straight lines, although a couple of assumptions and approximations have been made.

To determine the gradient and offset of these lines, a linear regression is performed. This is illustrated in the figure below.

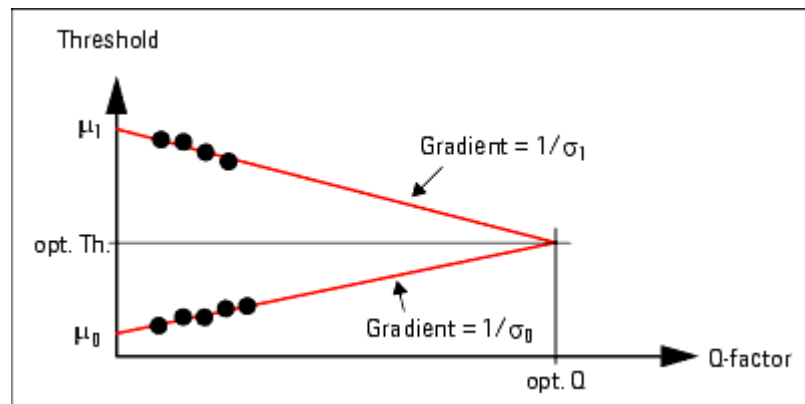

A straight line can be expressed as:

$$Y = A + BX$$

where Y is the inverse error function of BER, and X is D, the decision threshold.

The following calculations are performed for the high and low level data:

$$B = \frac{\Sigma XY - \frac{(\Sigma X)(\Sigma Y)}{n}}{\Sigma X^2 - \frac{(\Sigma X)^2}{n}}$$

$$A = \frac{\sum Y}{n} - B \frac{\sum X}{n}$$

where n is the number of respective data points.

The results of the linear regression are displayed in the **QBER vs. Threshold** graph.

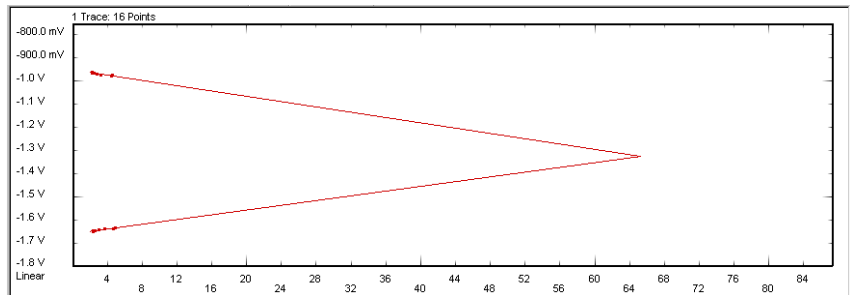

This graph shows two straight lines. The intersection of these lines marks the Q-factor and the Q optimum Threshold.

Mathematically, the standard deviation and mean values are calculated as:

$$\sigma = \left| -\frac{1}{B} \right|$$

$$\mu = \frac{-A}{B}$$

This calculation leads to the values of $\mu_{1,0}$ and $\sigma_{1,0}$.

Notes on the Q-Results

You can specify the range of data points used for these calculations by means of the **Min BER for Q** and **BER Threshold** parameters (see also “View Tab” on page 207).

Use of the Q-factor Calculations

For example, you can calculate the Q-factor from relatively few data points with measured bit error rates between 1e-10 and 1e-5. The calculation tells you the optimum decision threshold and also the BER expected when the error detector uses this threshold.

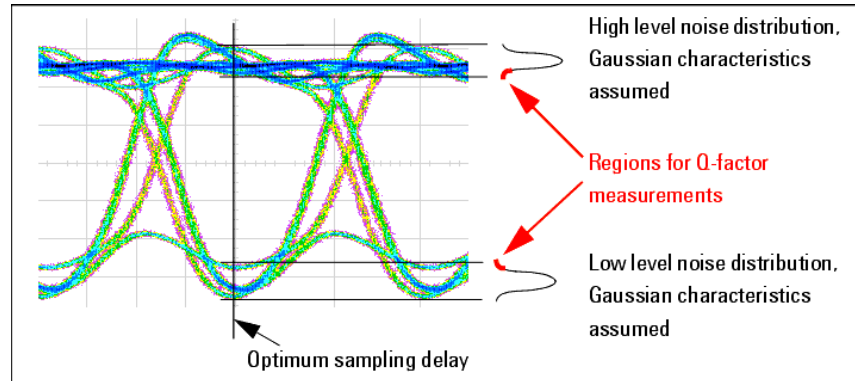

To measure such small bit error rates, you have to compare an adequate number of bits. Depending on the DUT characteristics, you may also have to use a very fine step size for the threshold variation.

Comparison of the Results

On the other hand, such a comparison may make it easier to understand the dependencies.

If you set the **BER Threshold** to a position that gives you only a few data points, you will find:

- The Q-factor is relatively high.
- The R^2 values are excellent (greater than 0.95).
- The mean levels and standard deviations returned by the Q-factor calculations differ from the measured values.

The **QBER vs. Threshold** graph may look as shown below:

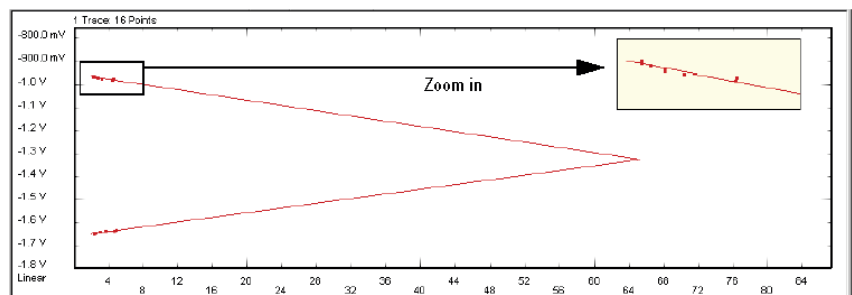

If you increase the **BER Threshold** to include more points, you will find:

- The mean levels and standard deviations returned by the Q-factor calculations approach the measured values.
- The Q-factor decreases.
- The R^2 values deteriorate.

The latter is caused by increasing nonlinearity. This can be inspected in the **QBER vs. Threshold** graph.

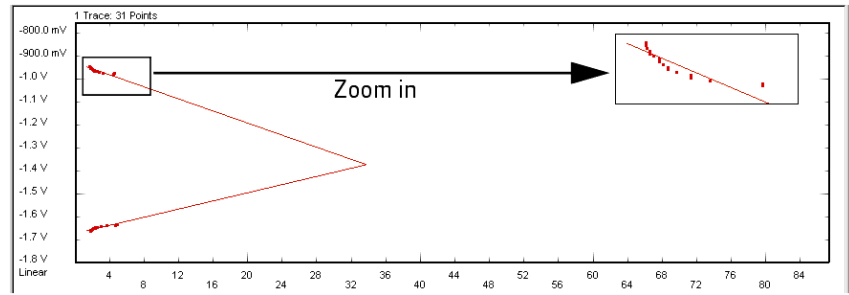

NOTE

The Q-factor calculations are disabled and flagged as "not applicable" if the R^2 value falls below 0.75.

The R^2 value can also be seen as an indicator of how well the noise distribution fits to Gaussian shape. It will not fit, for example, if the received signal is dominated by cross-talk or modal noise.

Eye Opening

Eye Opening - Concepts

The Eye Opening measurement generates a three-dimensional bit error rate (BER) diagram as a function of the sample delay and the sample threshold. With this measurement, the complete eye of the DUT output signal is measured. The results comprise the voltage and timing of the eye opening and the optimum sampling point.

To get the result, the sampling delay and the input threshold of the signal are shifted within 1.5 signal periods and a user-defined voltage range. The results comprise the voltage and timing of the eye opening and the optimum sampling point.

An example, that illustrates the general principle of the Eye Opening measurement is shown in the figure below.

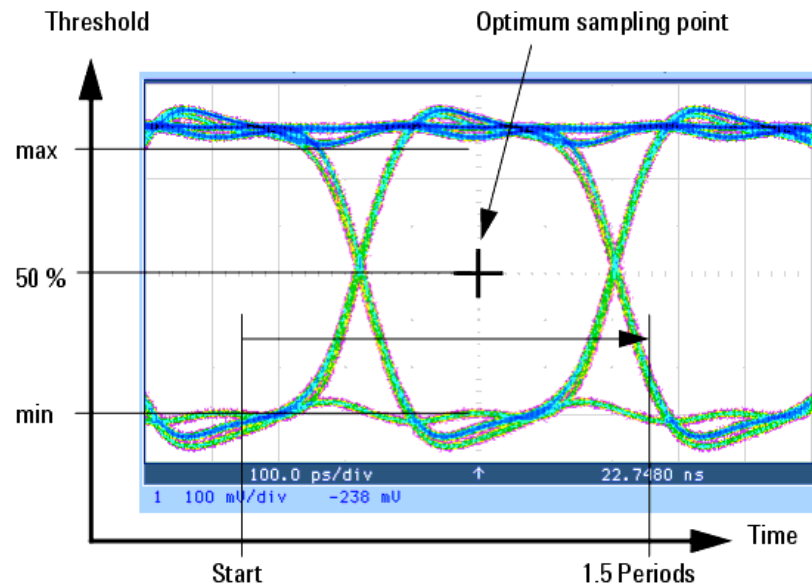

In detail, the measurement is not that simple and more precise as it derives the contour of the eye from the bit error rates that have been measured.

Three Available Views

The Eye Diagram can be visualized in three different ways:

- **Contour Plot**

The contour plot shows discrete lines of equal bit error rate—just like the contour lines on a map. The color of a line indicates the respective BER value. This graph is useful to visualize in which areas the BER changes—a homogeneous BER field will give you no lines at all.

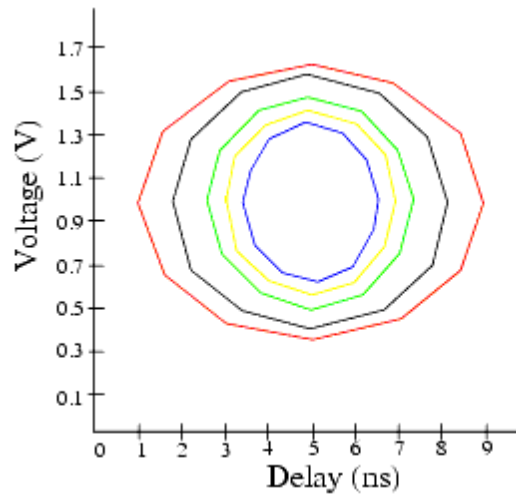

- **Pseudo Color Plot**

This plot visualizes the BER by a continuous color gradient. It uses different colors for the regions between the lines of equal BER. This is useful to get an immediate visual impression of the distribution of the BER in the eye diagram.

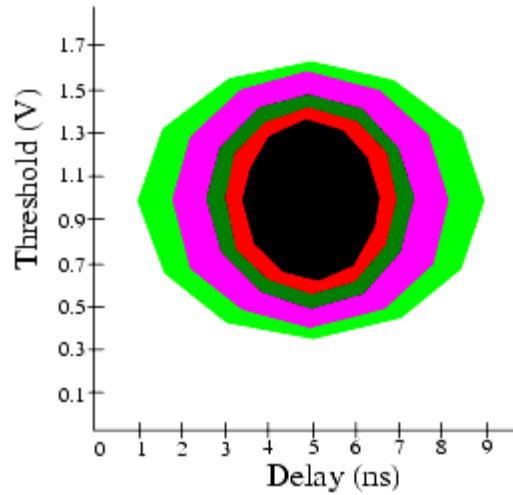

- **Equal BER at BER threshold**

This graph displays only one curve for the chosen bit error rate threshold.

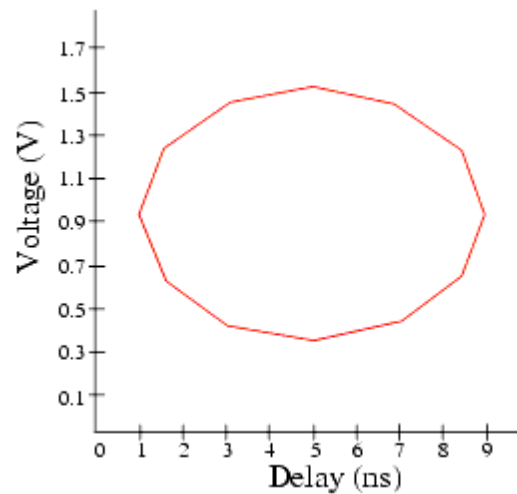

Example Results

The following figure shows the graphical result of a typical Eye Opening measurement:

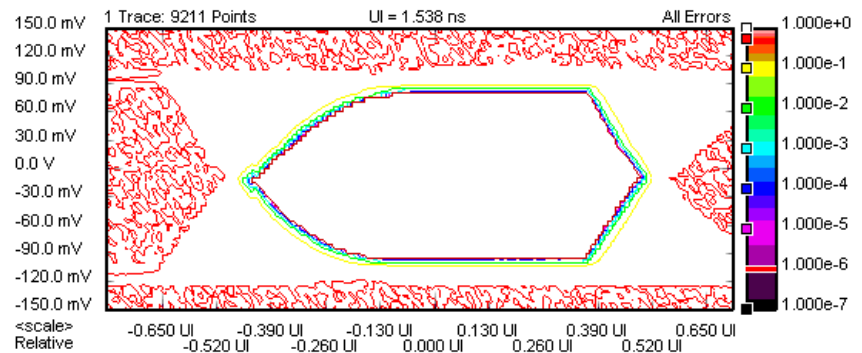

Eye Opening - Procedures

This section shows how to set up and perform an Eye Opening measurement. As an example we measure the eye diagram of a shielded cable.

This requires the following steps:

- Preparing the measurement (see [“How to Prepare the Eye Opening Measurement”](#) on page 224)

- Executing the measurement (see [“How to Execute the Eye Opening Measurement”](#) on page 225)
- Optimizing the view of the results (see [“How to Optimize the View of the Results”](#) on page 225)
- Using the color bar (see [“How to Use the Color Bar”](#) on page 226)
- Adding or changing colors (see [“How to Add or Change Colors”](#) on page 227)
- Changing the BER threshold (see [“How to Change the BER Threshold”](#) on page 227)
- Changing the BER range of a color (see [“How to Change the BER Range of a Color”](#) on page 228)

How to Prepare the Eye Opening Measurement

To prepare an Eye Opening measurement to test a shielded cable:

- 1** Disable the pattern generator outputs by pressing the **0V (Disable)** button in the **PG Output Setup** screen.
- 2** Use a shielded cable to connect the pattern generator's Data Out port and the error detector's Data In port.
- 3** Terminate all non-connected pattern generator output ports with 50 Ω .
- 4** Switch to the **Pattern** panel and press **Pattern Select**. Select an appropriate pattern, for example a pure $2^{15}-1$ PRBS, for both the pattern generator and the error detector.
- 5** For the pattern generator setup you need to specify the logic levels and the bit rate. Select **ECL** levels and a clock speed of 1250 MHz in this example. This corresponds to a clock period of 0.8ns. See [“Setting up the Pattern Generator - Concepts ”](#) on page 69 for more information.
- 6** Set up the error detector so that the input range and the termination matches the pattern generator's levels:
 - Select an **Input Range** from -2V to 0V
 - Set the **Data Termination** to -2V
 - Set the **Alignment BER Threshold** to 1E-6.
 - Set the **Clock Setup** to **Clock Data Recovery** to get the error detector's clock from the incoming data stream.
- 7** Enable the pattern generator outputs by pressing the **0V (Disable)** button.

- Press **Sync Now** and then **Auto Align** to find the optimum sampling point. Check that the synchronization and the alignment were successful. None of the error indicators should show red.

The resulting BER should be zero.

How to Execute the Eye Opening Measurement

To run the Eye Opening measurement:

- Switch to the **Analysis** panel and then press the **Eye Opening** icon.
- Press the **Start** button to execute the measurement.

The measurement is run and the display is continually updated. The following illustration shows the eye diagram of the measured bit error rate and-in the tabular view-the calculated results for the **Time Eye Opening**, the **Threshold Eye Opening**, the **Optimal Sample Delay** and the **Optimal Sample Threshold**.

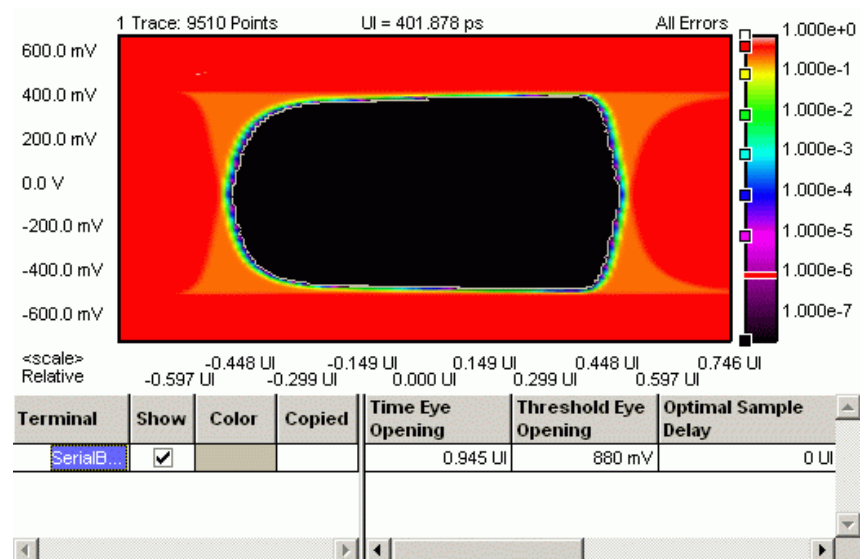

How to Optimize the View of the Results

After you have run a measurement, the resulting graph and the calculated numerical values are displayed. To improve the results, you can change the measurement parameters:

- Press the **Properties** button to open the **Properties** dialog box.
- Use the different tabs in this dialog box to make the required settings:
 - Parameters** tab

5 Advanced Analysis

These settings are used while the measurement is running. Changes require to run the test again. See “Parameters Tab” on page 229 for details.

– Pass/Fail tab

These settings determine whether the calculated results are recognized as passed or failed. However, a new test run is not required when doing changes here. See “Pass/Fail Tab” on page 230 for details.

– View tab, Graph tab, and Color tab

All settings on these tabs only affect the way the data is displayed. You do not need to run the measurement again. See “View Tab” on page 232, “Graph Tab” on page 234, and “How to Change the Colors of the Graph” on page 164 for details.

- 3 Press **OK** when you have made all required changes to close the **Properties** dialog box.

How to Use the Color Bar

The color bar at the right-hand side of the diagram shows the assignment of BER thresholds to colors. These colors can be changed. In addition, the color bar provides some useful options for controlling the display.

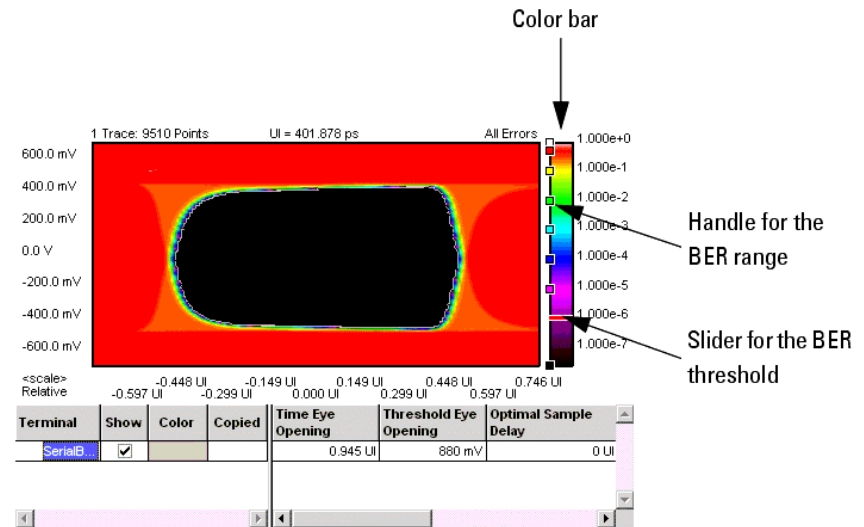

How to Add or Change Colors

If you have a mouse connected to your Serial BERT, you can add a color to the color bar or change a color:

- From the context menu of the color bar, choose from the following display options:

Table 25

Option	Description
Gradient	
Add color...	To add an additional color to the color gradient at the cursor position. The BER range for this new color will be assigned automatically.
Update Plots Dynamically	
Rainbow	To display a large variety of colors for the bit error ranges.
Yellow-Blue	To display a color gradient from color1 to color2 for the bit error ranges.
Green-Blue	
Red-Green	
Black-White	
White-Black	

How to Change the BER Threshold

The red slider indicates the present BER threshold. To use another value as threshold:

- Move the slider with the mouse (or your finger, if you are working directly on the Serial BERT).

This is particularly useful if you have set the display to show **Equal BER at BER Threshold**. By moving the slider, you can investigate the eye openings at distinct BER thresholds.

NOTE

If no slider for the BER threshold is displayed, make sure that you have enabled the **BER Threshold** option on the **View** tab and that a suitable BER is entered.

How to Change the BER Range of a Color

The bit error ranges are set automatically, but you can change these areas. To do so:

- Move the handles of a color with the mouse (or your finger, if you are working directly on the Serial BERT).

This is particularly useful if you have set the display to show the **Pseudo Color Plot**.

By default, you may see a graph like the one below:

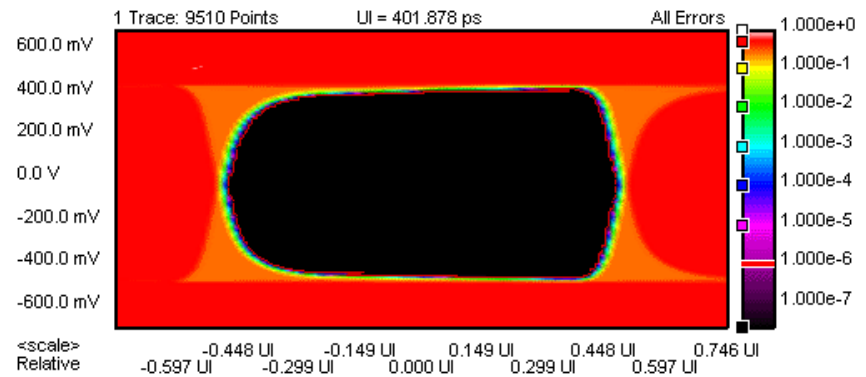

Now you may wish to know more precisely what happened between yellow and red. After extending the range of yellow, such information becomes available.

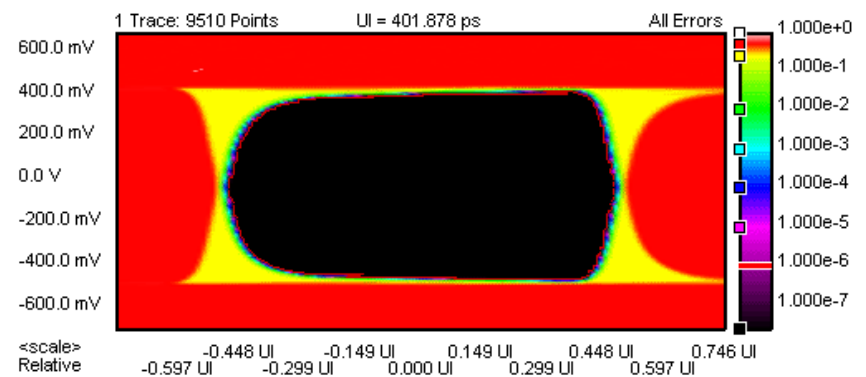

Eye Opening - Reference

The Eye Opening measurement returns the results in a graphical and in a numerical form. The following sections provide explanations of the measured parameters and the display options that are specific to this measurement. Additionally, some information is provided to explain the theoretical background behind.

Properties that can be specified on the various tabs of the **Properties** dialog box:

Parameters Tab

NOTE

If you modify the parameters on this page, you have to rerun the measurement to update the results.

Set the criteria for moving to the next sample point:

- **Number of Compared Bits**

After this number of compared bits, the measurement stops for the current sample point and moves to the next one.

The default is 1 million bits. That means, you can measure a bit error rate down to 10^{-6} (one error per million).

A smaller number reduces the duration of the whole Eye Opening measurement. A larger number increases the precision of the measured bit error rates.

- **Number of Errors**

After this number of errors, the measurement stops for the current sample point and moves to the next one. This allows you to speed up the measurement. You can switch off this option if only the number of compared bits is important.

NOTE

The measurement moves to the next sample point when the first of the two criteria is reached.

Set the criteria for the sample delay:

- **Resolution**

Specifies the distance between sampling points. The lower this value, the more sampling points you have in a unit interval. You can enter the resolution in UI or ps, ns, s, The timebase of the display is set on the **View** tab.

The default is 0.01 UI, that means, 100 points per unit interval will be measured.

- **Edge Resolution Optimization**

Turns the resolution optimization on or off. If this option is enabled, the Serial BERT intelligently sets a resolution so that there are more sampling points at the edges of the eye. This can greatly improve the results without dramatically increasing the duration of the test.

Set the criteria for the sample threshold:

- **Resolution**

Specifies how many measurement points are taken within the sample voltage range. Enter the value in mV.

- **Low Level**

Specifies the lower limit of the measurement voltage range. Enter the value in mV. This value should be slightly lower than the lowest expected signal voltage.

- **High Level**

Specifies the upper limit of the measurement voltage range. Enter the value in mV. This value should be slightly higher than the highest expected signal voltage.

Pass/Fail Tab

The **Pass/Fail** tab of the **Properties** dialog allows you to specify the criteria to decide whether the DUT passes or fails the test. You can change pass/fail criteria without rerunning the test. The software only uses the criteria to rate the results of a measurement.

NOTE

The pass/fail criteria do not control measurement execution. The measurement run will be completed even if the measurement fails one or more of the criteria.

You can set several pass/fail limits. For an explanation of the **Eye Opening Pass/Fail** criteria, see [“Measurement Parameters”](#) on page 235.

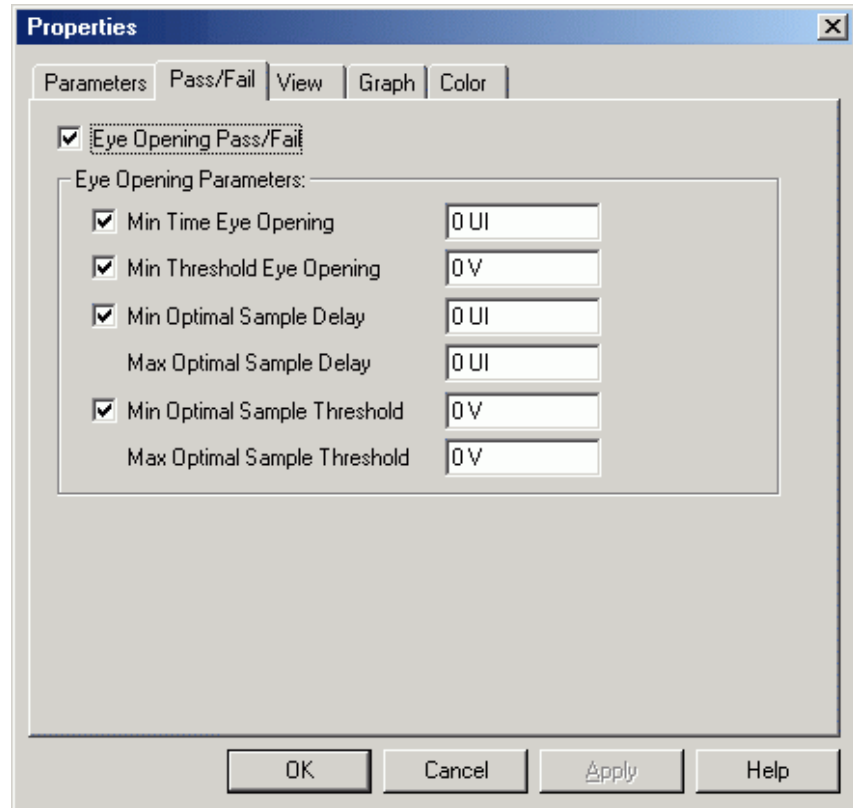

In the tabular view, each of the calculated values will be marked with an



icon if it failed the test.

The following illustration shows an Eye Opening measurement that has failed the criteria for the eye opening voltage.

5 Advanced Analysis

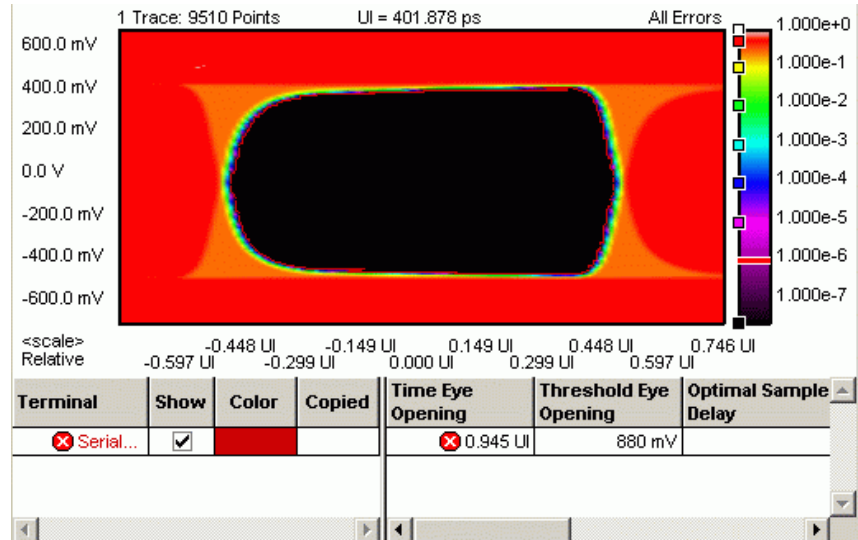

View Tab

The graph shows either a Contour Plot, a Pseudo Color Plot, or only one curve for the selected bit error rate threshold.

Contour plot The contour plot shows discrete lines of equal bit error rate—just like the contour lines on a map. The color of a line indicates the respective BER value. This graph is useful to visualize in which areas the BER changes—a homogeneous BER field will give you no lines at all.

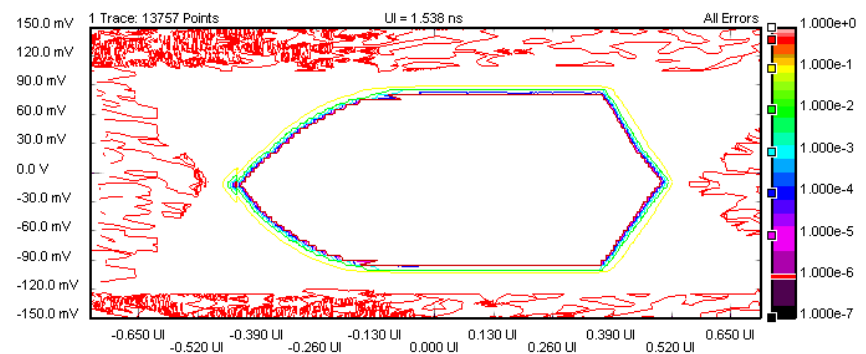

Pseudo Color Plot This plot visualizes the BER by a continuous color gradient. This is useful to get an immediate visual impression of the distribution of the BER in the eye diagram.

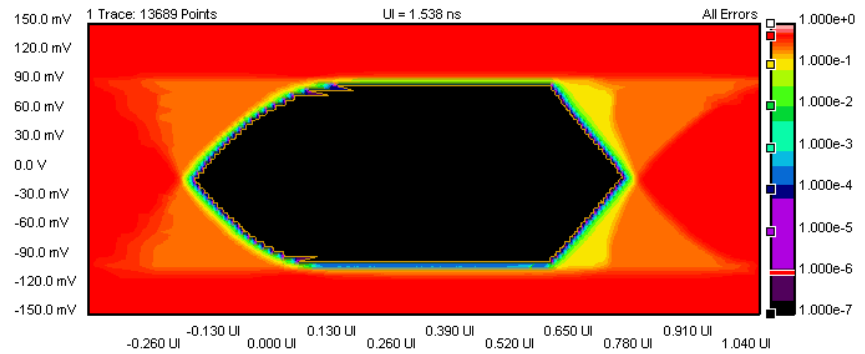

Equal BER at BER threshold It shows the contour line at the BER threshold.

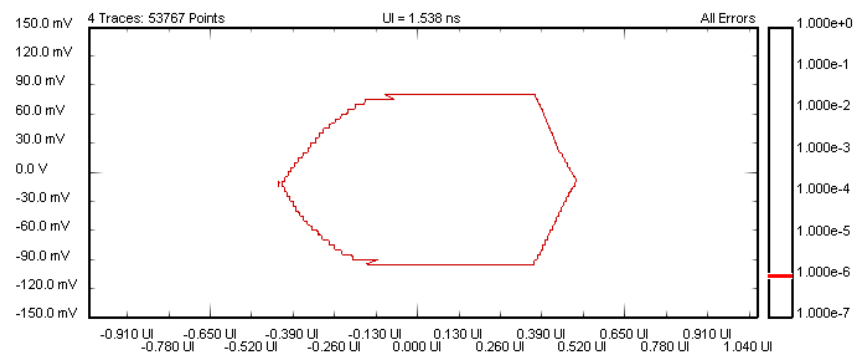

Furthermore, the following parameters can be set on the **View** tab of the **Properties** dialog box:

Analyze You can analyze for:

- **All Errors**
To display all errors.
- **Errors if 0s Expected**
To display the errors if "0" is expected, but "1" received.
- **Errors if 1s Expected**
To display the errors if "1" is expected, but "0" received.

Calculate You can calculate measurement parameters for:

- **0 Errors**
To calculate the parameters for 0 errors.
- **BER Threshold**
To calculate the parameters for the given BER threshold. The BER threshold influences all parameters of the Eye Opening

5 Advanced Analysis

measurement. You can also drag and drop the horizontal BER threshold in the graphical display to change this value.

Table Number Format You can select the number of **Decimal Places** to be displayed in the table.

Graph Tab

On the **Graph** tab, you can use the several options to optimize the graphical display according to your needs.

Timing Units Choose between **Unit Interval** and **Seconds** to select the timebase for the display's x-axis.

Markers To analyze the graphs at a particular point, you can use the markers. Additionally, you can display all related values for the markers in the marker readout.

Pressing the **Reset Markers** button will set the markers back to the default positions.

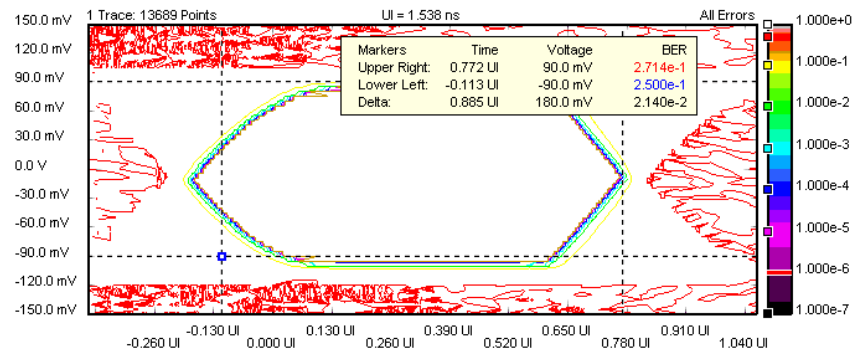

Zoom Several zoom factors are available. When you show the zoom graph, you can also allow the zoom graph to track the mouse (or your finger, if you are working directly on the Serial BERT).

Show Measured Points If you want to see the points that have actually been measured, choose **Show Measured Points**. The MUI uses linear interpolation for the graph.

Show BER Threshold If you want to display the BER threshold contour line, choose **Show BER Threshold**. The BER threshold is set on the **View** tab or by the slider in the Color Bar.

NOTE

If no slider for the BER threshold is displayed, make sure that you have enabled the **BER Threshold** option on the **View** tab and that a suitable BER is entered.

Explanation of the Numerical Results

Additionally to the graphical results, the measurement provides numerical results:

Measurement Parameters

The measurement parameters are defined in the following List:

- **Time Eye Opening**

This is the maximum extension of the BER threshold contour line in sample delay direction (eye width).

Note: This value is different from the horizontal extension of the BER threshold bounding box.

- **Threshold Eye Opening**

This is the maximum extension of the BER threshold contour line in sample voltage direction (eye height).

Note: This value is different from the vertical extension of the BER threshold bounding box.

- **Optimal Sample Delay**

This is the sample delay coordinate of the center of a bounding box around the BER threshold contour line.

- **Optimal Sample Threshold**

This is the sample voltage coordinate of the center of a bounding box around the BER threshold contour line.

Unavailable Values

If you make a measurement that results in an incomplete eye (no closed contour line at the BER threshold), the numerical results cannot be calculated. In this case, the software will issue a warning message.

If this happens, you should first of all check the settings of the low and high decision threshold voltages.

Understanding the Result Parameters

All result parameters are calculated from the BER threshold contour line and its bounding box. So, all parameters change with the BER threshold.

The result display of the Eye Opening measurement shows the maximum eye opening time, the maximum eye opening voltage, and the position of the optimum sampling point.

These parameters are derived as illustrated in the figure below:

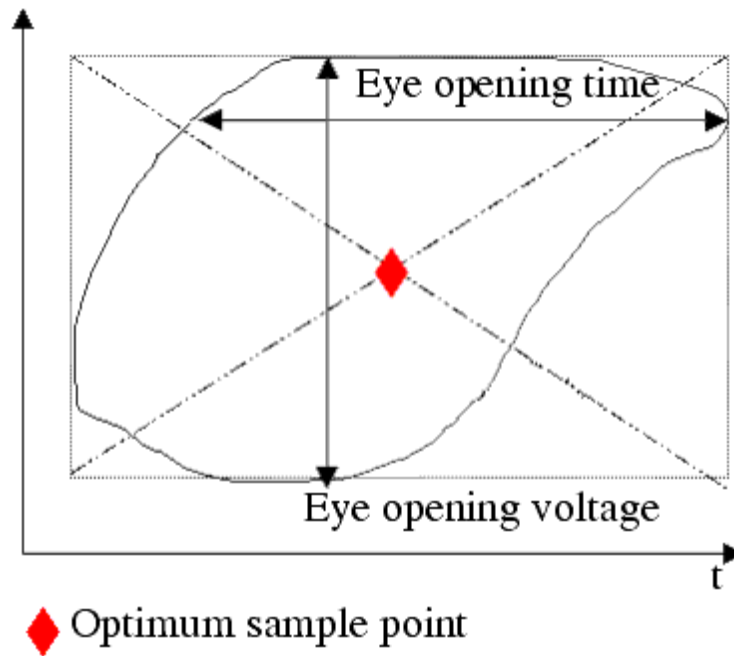

Error Location Capture

Error Location Capture - Concepts

The Error Location Capture measurement allows to capture the position of an errored bit in a memory-pased pattern. The instrument saves the position of the errored bit and writes a bit sequence neighbouring the errored bit to a file.

This feature can be used to find rare or random errors. A DUT could have problems handling long series of zeroes. Error Location Capture can be used to locate the bit errors in such cases.

NOTE

The measurement run is aborted by various actions, like selecting a new pattern or starting synchronization or alignment.

Example Results

The following figure shows the results of a typical Error Location Capture measurement:

Address	Current Run: Expected Data					
0	0011	1110	1011	0000	0101	
20	1100	0110	0111	1000	0101	
40	1101	0011	0001	0111	0010	
60	1100	1010	1000	0101	0110	
80	1101	1000	0100	1011	1011	
100	0110	1010	0110	0110	0101	
120	0011	1110	1011	0000	0101	
140	1100	0110	0111	1000	0101	
160	1101	0011	0001	0111	0010	
180	1100	1010	1000	0101	0110	
200						
220						
240						
260						

Stopped: Successful	Position: 80	Bin	Length: 200
Measurement	Current Run	Previous Run	
1st Bit-Error Location	80	-	
Bit-Error Count	128	-	

Important Requirements

In order to perform Error Location Capture measurements, the following requirements have to be met in addition to the ones listed in “General Requirements” on page 160:

- Only memory-based patterns with a unique 48-bit pattern (detect word) are allowed.
- No alignment features can run during error location capture: Auto Align, 0/1 Threshold Center, Data Center
- No other advanced measurement (Output Timing, Output Levels, etc.) can be running.

- Error Location Capture can only run when the BER Location Mode is set to more than one bit (for example, all bits, or a block with a length > 1).

Error Location Capture - Procedures

This section shows how to set up and perform an Error Location Capture measurement. As an example first add a couple of errors to an alternating pattern and then capture their position.

This requires the following steps:

- Preparing the measurement (see [“How to Prepare the Error Location Capture Measurement” on page 238](#))
- Demonstrating the measurement (see [“How to Demonstrate the Error Location Capture Measurement” on page 239](#))

How to Prepare the Error Location Capture Measurement

To prepare an Error Location Capture measurement to detect the location of an errored bit in an alternating pattern:

- 1 Disable the pattern generator outputs by pressing the **0V (Disable)** button in the **PG Output Setup** screen.
- 2 Use a shielded cable to connect the pattern generator's Data Out port and the error detector's Data In port.
- 3 Use a second shielded cable to connect the pattern generator's Clock Out port and the error detector's Clock In port.
- 4 Terminate all non-connected pattern generator output ports with 50 Ω .
- 5 Make sure to preset the instrument state before running the measurement: Select **Preset Instrument State** from the **File** menu.
- 6 Enable the pattern generator outputs by pressing the **0V (Disable)** button.
- 7 Press **Sync Now** and then **Auto Align** to find the optimum sampling point. Check that the synchronization and alignment were successful. None of the error indicators should show red.

The resulting BER should be zero.

How to Demonstrate the Error Location Capture Measurement

To demonstrate the Error Location Capture measurement:

- 1 Switch to the **Pattern** panel and press the **Open** button. Load a Fiber Channel random data pattern from the demo patterns (Demo > Fiber Channel > RPAT.ptrn).

Press the **Properties** button and set the **Pattern Type** to **Alternate**. To display both halves of the alternate pattern, press the **Alt pat view** button.

Ensure also that the error detector tracks the pattern generator.

- 2 Insert two errors into pattern B. To do so, edit bits 80 and 100 of pattern B in overwrite mode.
- 3 Write the modified pattern to the pattern generator and the error detector by pressing the **ToPG&ED** button.
- 4 For the pattern generator setup you need to specify the **Alternate Pattern and Aux In**. Set the **Internal Alternate Pattern Mode** to **Single Shot B** and disable **Aux In**.
- 5 Set up the error detector so that the **Clock Setup** is set to **Clock Data Recovery** to get the error detector's clock from the incoming data stream.
- 6 Switch to the **Analysis** panel and then press the **Error Location Capture** icon.
- 7 Press the **Start** button to execute the measurement.
Status information is displayed in the lower section of the display.
- 8 Press **Insert B** button.

The two captured errors are illuminated red in the captured pattern grid. In the result list, the **1st Bit-Error Location Capture** indicates an error in bit 80. Use the error navigation buttons (e.g. **Next Error**, **Prev. Error**) to display further bit errors in the captured pattern.

Error Location Capture - Reference

The Error Location Capture measurement compares the expected pattern and the pattern that was actually received, and shows the received pattern with the errored bits marked.

Elements of the User Interface

The following buttons help you to analyze the results:

- **Hex / Bin**

Choose between a binary or hexadecimal display of the pattern. The current setting is shown in the status bar below the pattern window.

Note that in hexadecimal view the captured error can only be located as being one of a group of four bits. To display which of the four bits is the errored bit, you have to switch to the binary display.

- **Exp. / Cap.**

(**Expected/Captured**) Toggle the data view between the display of the expected data, i.e. the data you defined on the error detector, and the captured data, i.e. the data that was captured at the error detector. The current state is displayed in the title bar of the pattern grid.

- **Run Select**

Toggle the data view between the current run and the previous run.

After a measurement run is successfully finished, the display is automatically switched to the current run. The current state is displayed in the title bar of the pattern grid.

- **First Error**

Jumps to the first errored bit in the pattern.

- **Prev. Error**

Jumps to the previous errored bit in the pattern.

- **Next Error**

Jumps to the next errored bit in the pattern.

- **Last Error**

Jumps to the last errored bit in the pattern.

Explanation of the Results

The results are shown in various ways:

Graphic View The graphic view highlights the located bit errors. The currently selected bit is highlighted in red, all other errored bits are written in red.

Status Bar The status bar below the graphic view provides the following information:

- **Status:** The status indicates if the measurement is running or has ended. If the measurement has ended, it indicates if the measurement ended successfully or was aborted.

- **Position:** The position of the current errored bit is shown.
- **Hex/Bin:** This field indicates how the data is shown (bin or hex format).
- **Length:** This field indicates the length of the captured data. Note that the value here does not equal the length of the pattern.

Compare Pattern File

The captured data is saved as an alternating pattern:

- Pattern A contains the expected data.
- Pattern B contains the errored data:
0s if the expected bits were also received, 1s for errored bits.

To calculate the captured pattern, XOR the bits from pattern A with the bits from pattern B.

The pattern description contains the first error, the error count, date and time.

The name of the pattern file is ELOC_RESULT_CURRENT.ptrn for the current capture and ELOC_RESULT_PREVIOUS.ptrn for the previous capture. These patterns are saved under C:\N4903A\Pattern on the machine with the firmware server.

Results Window

The results are displayed in the window below the pattern. You can compare the results of the Current Run with the results of the Previous Run:

- **1st Bit-Error Location:**
Address of the first captured errored bit.
- **Bit Error Count:**
Number of all errored bits captured during the measurement.

Fast Eye Mask

Fast Eye Mask - Concepts

The Fast Eye Mask measurement is first of all meant for production and screening tests. It allows to determine very quickly whether the eye

opening seen at the output signal of a device is within specifications, that is, within certain timing and voltage limits.

Measuring the eye openings with an oscilloscope used to be a time-consuming procedure. With the Fast Eye Mask measurement of the Serial BERT, pass/fail information can be obtained within seconds.

This is achieved by measuring the bit error rate at a limited number of test points. Up to 32 measurement points can be specified, each defined by a sampling time relative to the actual sampling point (which can be the optimum sampling point) and a threshold voltage (which is adaptive). In practice, six measurement points will often suffice to approximate the shape of the eye. Six measurement points are preset by default.

NOTE

The Fast Eye Mask can be run by using the appropriate SCPI commands, making it possible to integrate the Serial BERT into a testing environment. See the Programming Guide for details.

Example Results

The Fast Eye Mask measurement measures the bit error rate at certain measurement points. These points have to be positioned inside the expected eye opening.

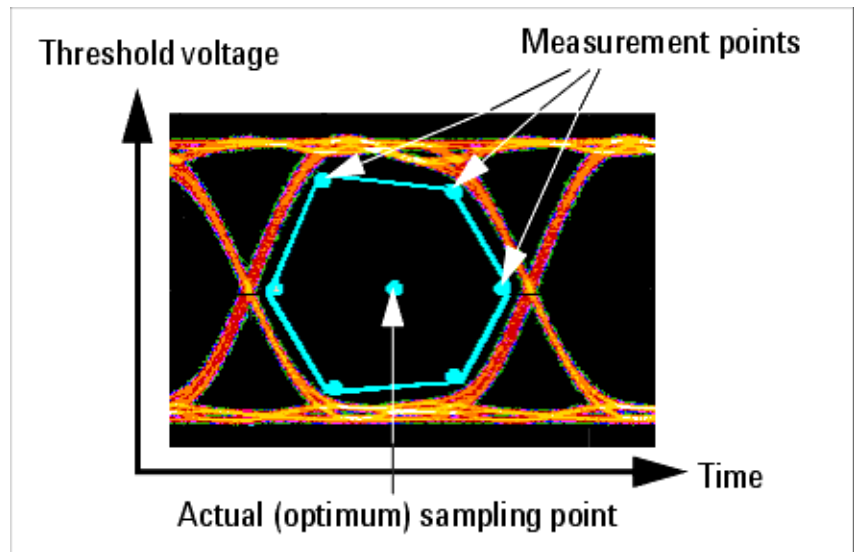

The results of a Fast Eye Mask measurement are displayed in numerical form:

Terminal	Cop1	1	2	3	4	5	6
Relative Time		-0.4 UI	0.4 UI	-0.16 UI	0.16 UI	-0.16 UI	0.16 UI
Voltage(abs)		-22.4 mV	-22.4 mV	178 mV	178 mV	-222 mV	-222 mV
SerialBERT		0	0	0	0	0	0
Voltage(abs)		-22.4 mV	-22.4 mV	178 mV	178 mV	-222 mV	-222 mV

The rows **Relative Time** and **Voltage** define the positions of the measurement points. The last row shows the measured bit error rates at these points.

- The **Relative Time** of the measured points refers to the actual sampling point. If synchronization and auto-alignment were successful, the current sampling point is the optimum sampling point.

Instead of UI (one **Unit Interval** is equal to one system clock period), the relative time can also be specified in seconds.

- The **Voltage** is the decision threshold voltage at this measurement point. The voltages of the measurement points can be set as absolute voltages, as offset voltages, or as percentages. This is done on the **Parameters** page of the **Properties** dialog.

By default, the six measurement points are symmetrically placed, as illustrated in the figure below:

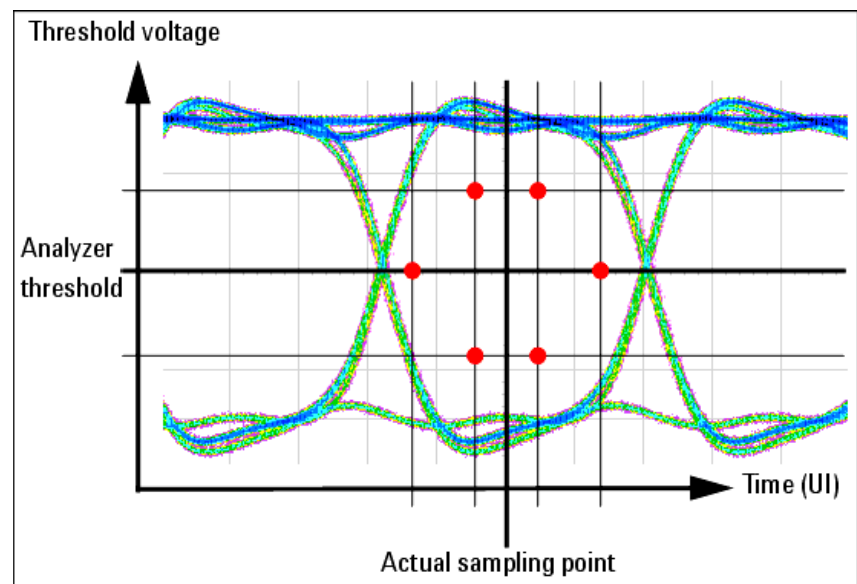

These settings can be changed, and up to 32 measurement points can be defined.

NOTE

Critical areas at the error detector are generally close to ± 0.5 UI.

Fast Eye Mask - Procedures

This section shows how to set up and perform a Fast Eye Mask measurement. As an example we measure the eye of a shielded cable.

This requires the following steps:

- [“How to Prepare the Fast Eye Mask Measurement” on page 244](#)
- [“How to Execute the Fast Eye Mask Measurement” on page 245](#)
- [“How to Optimize the View of the Results” on page 245](#)

How to Prepare the Fast Eye Mask Measurement

To prepare a Fast Eye Mask measurement to test a shielded cable:

- 1 Disable the pattern generator outputs by pressing the **0V (Disable)** button in the **PG Output Setup** screen.
- 2 Use a shielded cable to connect the pattern generator's Data Out port and the error detector's Data In port.
- 3 Terminate all non-connected pattern generator output ports with 50 Ω .
- 4 Use a shielded cable to connect the pattern generator's Data Out port and the error detector's Data In port.
- 5 Switch to the **Pattern** panel and press **Pattern Select**. Select an appropriate pattern, for example a pure 2¹⁵-1 PRBS, for both the pattern generator and the error detector.
- 6 For the pattern generator setup, you need to specify the logic levels and the bit rate. Select **ECL** levels and a clock speed of 1250 M Hz in this example. This corresponds to a clock period of 800ps. See [“Setting up the Pattern Generator - Concepts ” on page 69](#) for more information.
- 7 Set up the error detector so that the input range and the termination matches the pattern generator's levels:
 - Select an **Input Range** from -2V to 0V
 - Set the **Data Termination** to -2V
 - Set the **Alignment BER Threshold** to 1E-6.
 - Set the **Clock Setup** to **Clock Data Recovery** to get the error detector's clock from the incoming data stream.
- 8 Enable the pattern generator outputs by pressing the **0V (Disable)** button.

- 9 Press **Sync Now** and then **Auto Align** to find the optimum sampling point. Check that the synchronization and the alignment were successful. None of the error indicators should show red.

The resulting bit error rate should be zero.

How to Execute the Fast Eye Mask Measurement

To run the Fast Eye Mask measurement:

- 1 Switch to the **Analysis** panel and then press the **Fast Eye Measurement** icon.
- 2 Press the **Start** button to execute the measurement.

The measurement is run and the result window shows the bit error rates measured at six measurement points.

Terminal	Copi	1	2	3	4	5	6
Relative Time		-0.4 UI	0.4 UI	-0.16 UI	0.16 UI	-0.16 UI	0.16 UI
Voltage(abs)		-22.4 mV	-22.4 mV	178 mV	178 mV	-222 mV	-222 mV
SerialBERT		0	0	0	0	0	0
Voltage(abs)		-22.4 mV	-22.4 mV	178 mV	178 mV	-222 mV	-222 mV

The **Relative Time** refers to the current sampling point.

The **Voltages** are the decision threshold voltages for measuring the bit error rate at this measurement point. The voltages of the measurement points can be set as absolute voltages, as offset voltages, or as percentages.

How to Optimize the View of the Results

After you have run a measurement, the resulting numerical values are displayed. To improve the results, you can change the measurement parameters:

- 1 Press the **Properties** button to open the **Properties** dialog box.
- 2 Use the different tabs in this dialog box to make the required settings:
 - **Parameters** tab

These settings are used for data collection. Changes require to run the test again. See [“Parameters Tab” on page 246](#) for details.
 - **Pass/Fail** tab

These settings determine whether the calculated results are recognized as passed or failed. However, a new test run is not required when changes are made here. See [“Pass/Fail Tab” on page 248](#) for details.
 - **View** tab

All settings on this tab only affect the way the data is displayed. You do not need to run the measurement again. See [“View Tab” on page 248](#) for details.

- 3 Press **OK** when you have made all required changes to close the **Properties** dialog box.

Fast Eye Mask - Reference

The Fast Eye Mask measurement returns the results in a numerical form. The following sections provide explanations of the measured parameters and the display options that are specific to this measurement.

Properties that can be specified on the various tabs of the **Properties** dialog box:

Parameters Tab

Note that if you modify the parameters on this page, you have to rerun the measurement to update the results.

Set the criteria for moving to the next sample point:

- **Number of Compared Bits**

After this number of compared bits, the measurement stops for the current sample point and moves to the next one.

The default is 1 million bits. That means, you can measure a bit error rate down to 10^{-6} (one error per million).

A smaller number reduces the duration of the whole Fast Eye Mask measurement. A larger number increases the precision of the measured bit error rates.

- **Number of Errors**

After this number of errors, the measurement stops for the current sample point and moves to the next one. This allows you to speed up the measurement. You can switch off this option if only the number of compared bits is important.

NOTE

The measurement moves to the next sample point when the first of the two criteria is reached.

Set the criteria how the sampling points of the eye are displayed:

- **Timing Unit**

Choose between **Unit Interval** and **Seconds** to set the timing values for the measurement points on the **Parameters** tab. This setting does not affect the display of results.

- **Threshold Type**

Choose between **Absolute**, **Offset**, or **Percentage** to set the thresholds for the measurement points:

- **Absolute**

You specify the thresholds for the measurement points as absolute voltages.

- **Offset**

You specify the thresholds for the measurement points relative to the threshold voltage of the actual sampling point.

- **Percentage**

You specify the thresholds for the measurement points as a percentage of the current eye opening voltage of the error detector.

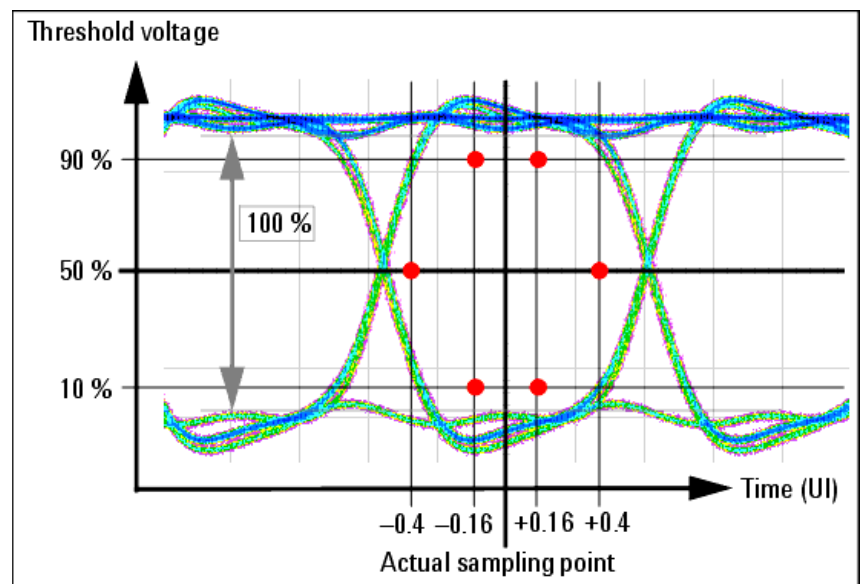

Depending on the quality and characteristics of the eye opening, the resulting 50% threshold may deviate from the decision threshold defined in the loaded setting.

- **Number of Valid Points**

Change the **Number of Valid Points**, if you wish to use less or more measurement points for the measurement.

- **Relative Time and Voltage**

In the table at the bottom of the **Parameters** tab you can change measurement points. Enter the **Relative Time** and **Voltage** according to the above settings.

Pass/Fail Tab

The **Pass/Fail** tab of the **Properties** dialog box allows you to specify the criteria to decide whether the DUT passes or fails the test. You can change pass/fail criteria without rerunning a test. The software only uses the criteria to rate the results of a measurement.

NOTE

The pass/fail criteria do not control measurement execution. The measurement run will be completed even if the measurement fails one or more of the criteria.

The Fast Eye Mask measurement has only one pass/fail condition: The bit error rate. If desired, enable the **BER Threshold** and set a suitable threshold.

NOTE

The **BER Threshold** will usually be 0, since you want the measurement to fail if a single bit was received in error.

The pass/fail threshold applies to all measurement points. An



icon indicates all measurements where the bit error rate is higher than this threshold, as shown in the figure below:

Terminal	Copied	1	2	3	4	
Relative Time		-0.4 UI	0.4 UI	-0.160 UI	0.160 UI	.
Voltage(abs)		1 V	1 V	700.000 mV	700.000 mV	30
SerialBERT		1.33	0	0	0	

View Tab

The following parameters can be set on the **View** tab of the **Properties** dialog box:

Analyze You can analyze for:

- **All Errors**

To display all errors.

- **Errors if 0s Expected**

To display the errors if "0" is expected, but "1" received.

- **Errors if 1s Expected**

To display the errors if "1" is expected, but "0" received.

Grid You can set the **Timing Unit** for the display of the relative time of the measurement points on the Parameters tab. Choose between **Unit Interval** and **Seconds** to select the unit.

Table Number Format You can select the number of **Decimal Places** to be displayed in the table.

Eye Diagram

Eye Diagram - Concepts

The Serial BERT provides quick design analysis with the Eye Diagram capability. The Eye Diagram allows a quick check for the DUT's signal output, and determines the signal quality. Due to the higher sampling depth of a BERT value, the eye contour lines display the measured eye at a deeper BER level, for accurate results.

The Eye Diagram feature provides the following measurement capabilities:

- Eye Diagram Waveform
- BER Contour Lines
- Automatic Measurement for the most relevant eye parameters:-
 - Eye Height
 - Eye Width
 - Jitter P-P
 - Jitter RMS
 - Cross Voltage
- Markers
- Eye Mask

The Eye Diagram generates a three dimensional graph of the bit error rate (BER). This measurement helps in determining and analyzing the quality of the DUT's signal output. The Eye Diagram results comprise of voltage(y), time(x), and BER(z).

The Eye Diagram, and the table of Automated Eye Parameter Measurement form simultaneously. They become more precise with the increasing number of measured bits.

The following graph shows how the Eye Diagram has been integrated on the J-BERT N4903A High-Performance Serial BERT.

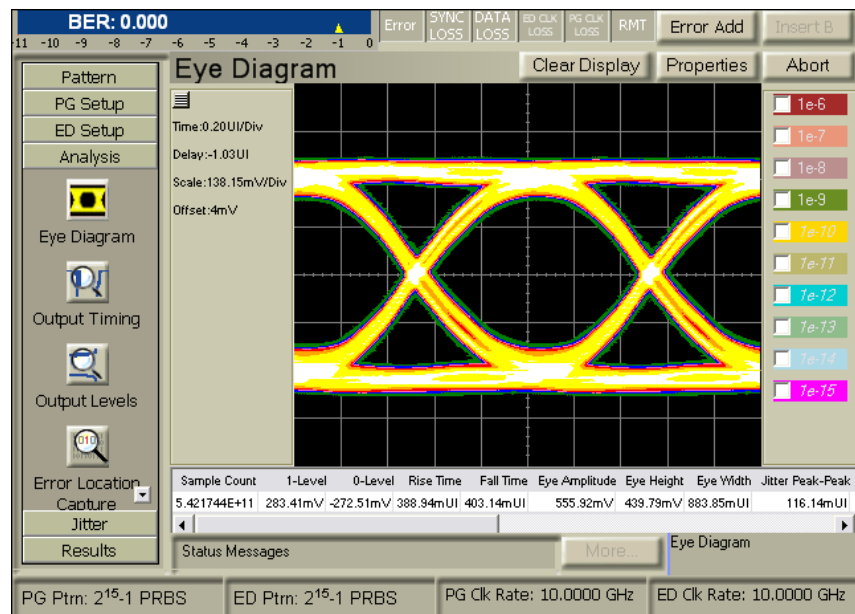

Methods of Representations

There are two methods of representing the eye diagram:

- Waveform
- Contour

Waveform

Waveform is the shape, and form of a signal. The waveform graph shows the periodical variation of voltage against time.

The waveform in the Serial BERT is similar to the one in the oscilloscope. In this case, the waveform initially gives a coarse, but quick

picture of the signal quality; while the 'smooth waveform' quickly generates a high resolution graph. The waveform is displayed in an incremental way, showing the coarse picture quickly, and then refining it further.

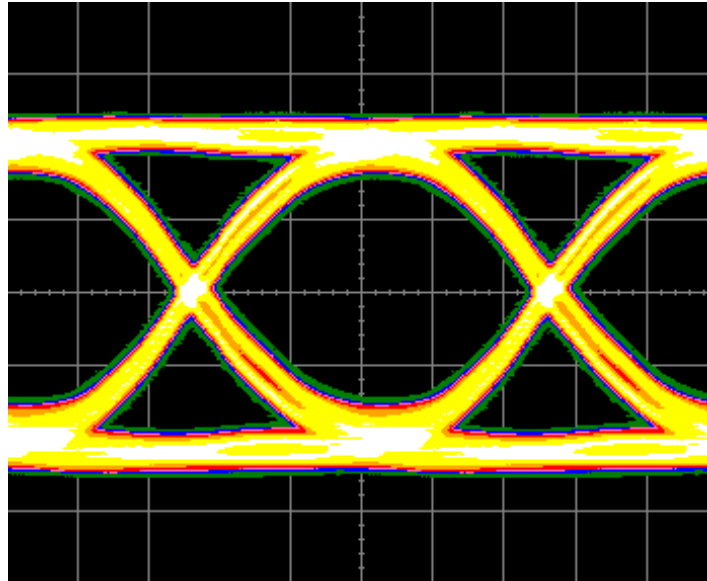

The BER Threshold is configurable. The BER Threshold is the level up to which the signal is represented as waveform, and BER values below this threshold are represented as contours.

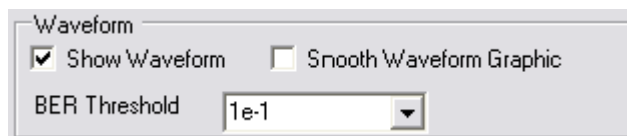

BER Contour

Contour is a curve connecting points where the BER has a same particular value. The contour graph is plotted within the Eye Diagram, and it helps to determine the Eye Opening at deep bit error rates, such as $1e-10$, $1e-12$, and so forth. Depending upon the user's requirement the deep BERs can be calculated. The extrapolated eye contour lines display the eye opening for lower BER levels, such as $1e-15$. The BER is displayed as a function of sampling delay, and sampling threshold.

The eye opening is one of the main characteristics of a high speed device.

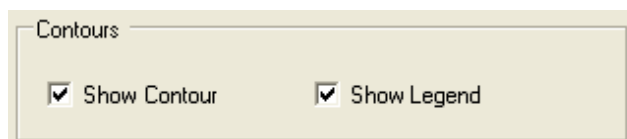

The legend on the right side of the screen represents the contour BER values in different colors. When you select a BER value from the legend, it displays the contour for the selected BER in the same color. Initially all the BER values on the legend are struck across. When the contour is measured, the BER value changes into normal font; and when the contour is extrapolated the BER value changes into *italics*. A BER value for which a Contour does not exist is struck across. You can select multiple BER values. The lower BER values are in red and pink, while the deep BER values are in green and blue. The screen shot below displays the contour and the legend.

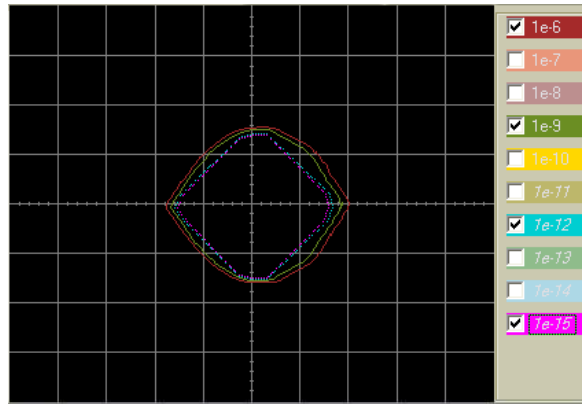

The outer contour represents the measured BER contour, while the inner lines are extrapolated. For more details on extrapolation see [“Estimated Total Jitter” on page 177](#)

The Minimum Number of Errors indicates the minimum number of hits required to plot the contour.

Eye Mask Measurement

Masks are marked regions on the screen. When the mask region and waveform intersect it is called a violation. The Mask test shows the quality of the eye.

When the mask measurement begins, the instrument either aligns the mask as per the eye levels of the waveform, or as per the absolute voltages specified in the mask file. The position of the mask can be changed by scaling the mask according to the eye. Once the masks are positioned the mask test counts the number of times a particular pixel falling in the mask region has been measured. The mask violations are marked in green. A consolidated report of the test is available on the left bottom of the graph. The user can turn off the mask computation by pressing the “stop” button.

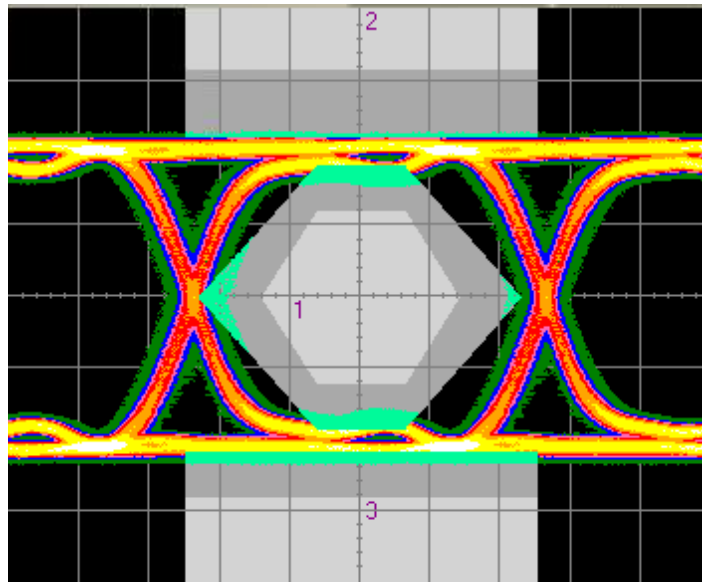
**NOTE**

The mask test is enabled when "centre to" is set to "middle of eye", and "persistence" is set to "infinite" in the Parameter Tab.

Automated Eye Parameter Measurement

Automated Eye Parameter Measurement characterizes an Eye Diagram by measuring the rise time, the fall time, the eye amplitude, and so forth. These measurements are called, Automated Eye Parameter Measurement, they display the Eye behavior, and they depend on the parameters set in the View Tab.

These results are displayed in a tabular form as shown below:

Sample Count	1-Level	0-Level	Rise Time	Fall Time	Eye Amplitude	Eye Height	Eye Width	Jitter Peak-Peak
1.304922E+08	300.00 mV	-300.00 m	0.03 UI	0.04 UI	600.00 mV	516.11 mV	0.39 UI	0.01 UI

Jitter Peak-Peak	Jitter RMS	Cross Voltage	Signal to Noise Ratio	Duty Cycle Distortion	Extinction Ratio
0.01 UI	0.01 UI	49.67%	252.17	0.01 UI	<No Data>

Optical Modulation Amplitude	Average Power
<No Data>	<No Data>

In case you want to see a specific set of Eye Measurements you can select it on the Eye Measurements tab.

NOTE

The scroll bar at the bottom of the table shows the entire table and its contents. For more details refer to [“Eye Diagram - Reference” on page 267](#)

Eye Diagram - Procedures

This section lists out some of the generic processes to set up measurements, to run them, and to create Eye Diagrams.

In this section, you will learn about:

- [“How to Prepare the Eye Diagram Measurement?” on page 254](#)
- [“How to Initiate an Eye Diagram Measurement?” on page 255](#)
- [“How to Change the Default Settings of an Eye Diagram?” on page 256](#)
- [“How to Set Markers?” on page 260](#)
- [“How to Run the Mask Measurement?” on page 261](#)
- [“How to Customize Mask Files” on page 262](#)
- [“How to Enter Notes?” on page 264](#)
- [“How to Save and Recall” on page 265](#)
- [“How to Export Fetched Data?” on page 265](#)

How to Prepare the Eye Diagram Measurement?

An example to prepare an Eye Diagram measurement:

- 1** Click **0V (Disable)** on the PG Output Setup screen, to disable the pattern generator outputs.
- 2** Connect the DUT to the pattern generator’s **Data Out** port and the error detector’s **Data In** port. Refer to the Getting Started Guide.
- 3** Terminate all non-connected pattern generator output ports with 50 Ohm.
- 4** Switch to the Pattern panel and click **Pattern Select**.
- 5** Select an appropriate pattern, for example a pure **2¹⁵-1 PRBS**, for both the pattern generator and the error detector.
- 6** Specify the logic levels and the bit rate for the pattern generator setup. For example, select ECL levels and a clock speed of 1250 MHz. This corresponds to a clock period of 0.8 ns.

- 7 Set up the error detector to match the input range and the termination with the pattern generator's levels:
 - Select an Input Range from -2 V to 0 V
 - Set the Data Termination to -2 V
 - Set the Alignment BER Threshold to $1\text{E}-6$
 - Set the Clock Setup to Clock Data Recovery to get the error detector's clock from the incoming data stream.
- 8 Enable Output

How to Initiate an Eye Diagram Measurement?

To run the eye diagram measurement:

- 1 Click the **Analysis** tab on the left panel.
- 2 Click the **Eye Diagram** icon.



- 3 Click the Start button to execute the measurement.



The measurement runs, and the eye diagram along with the Automated Eye Parameter Measurement get updated constantly.

The following graph shows the eye diagram.

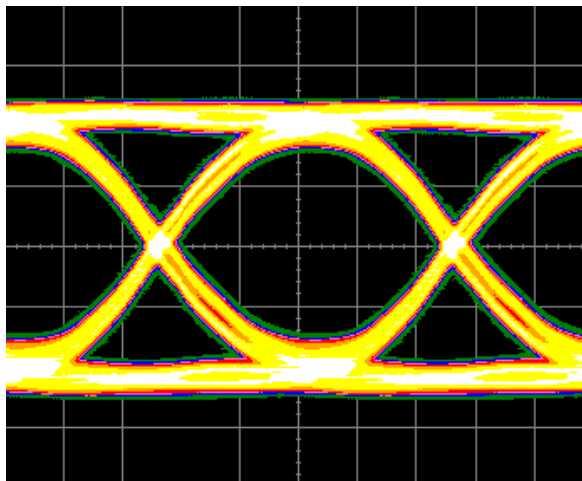

- 4 To stop the measurement click on Abort.

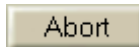

How to Change the Default Settings of an Eye Diagram?

To achieve desired results, you can change the measurement parameters:

- 1 Click the **Properties** button to open the Properties dialog box.

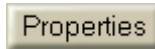

- 2 Use the different tabs in this dialog box to make the required settings:



- **Parameters** tab

The Parameter settings used for the measurement can be changed only when the measurement is not running, and if the settings are changed, then you will have to re-run the measurement. (Refer to “Parameters” on page 267 for the detailed options).

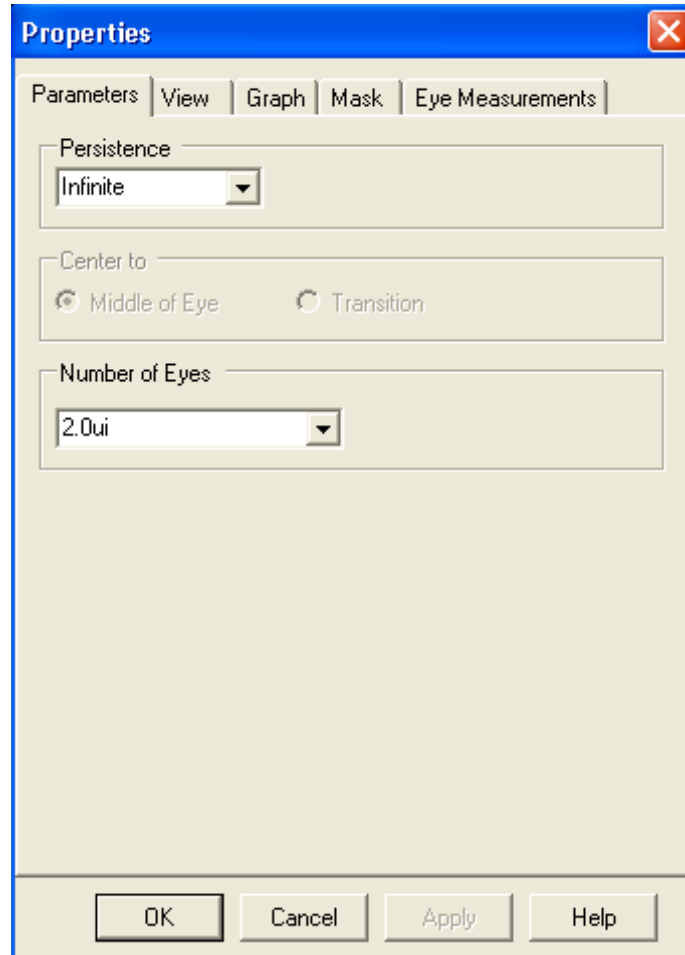

– **View** tab

The view tab options set the parameters to measure, and choose units for the displayed results in the numerical table. (Refer to “View” on page 268 for the detailed options)

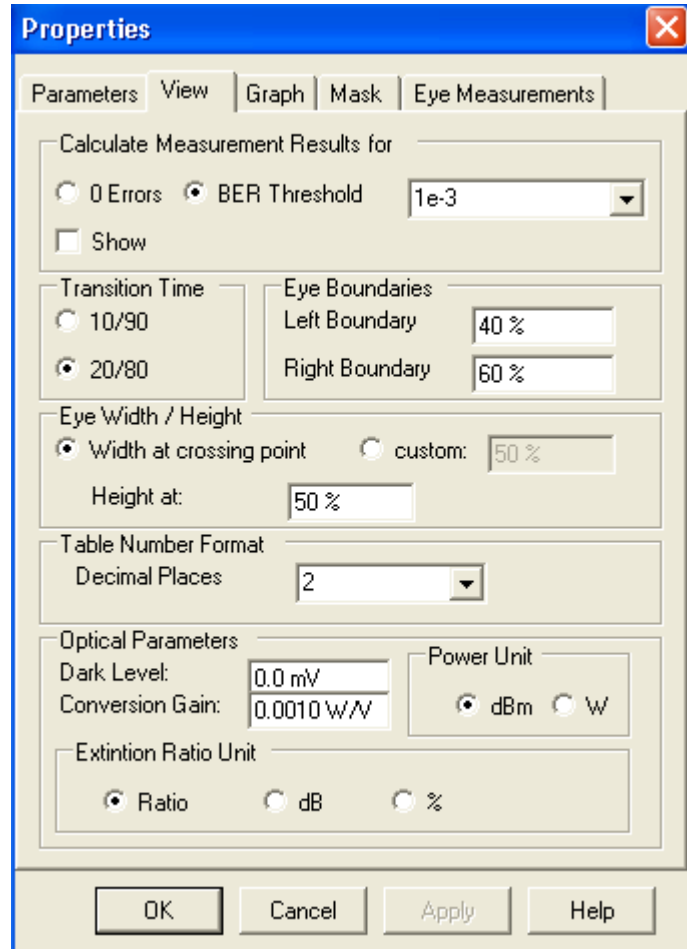

– **Graph** tab

The graph settings give the display parameters like timing units, waveform, contour, grid and markers.

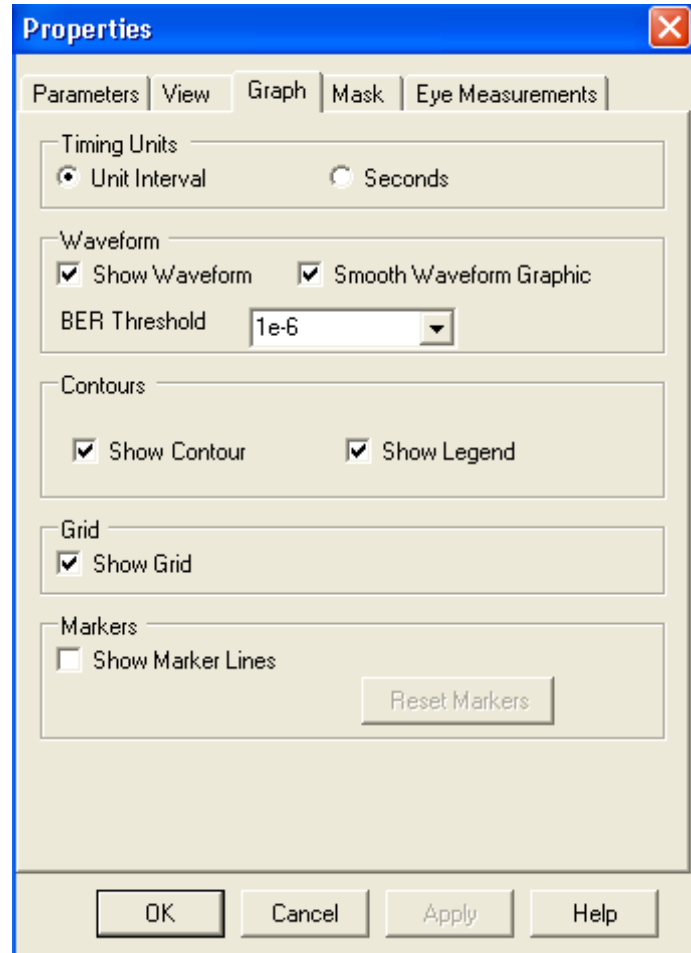

– **Eye Measurementstab**

The Eye Measurements tab lists out all the measurements. The user can select specific results.

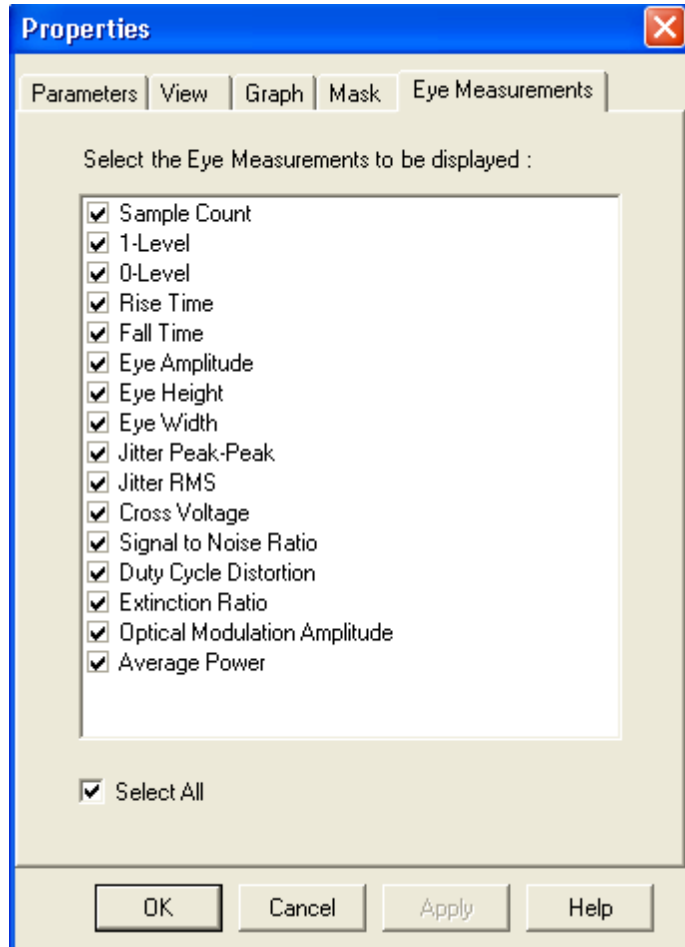

How to Set Markers?

Markers help in tracking the BER at specific points, so to set the markers:

- 1 Click on the **Graph** tab
- 2 Select **Show Marker Lines**



- 3 **Apply Setting**

This enables the markers, and a marker readout button appears on the top left corner. You also have an option to Reset Markers to their original position.

RBer:5.00E-001
 LBer:5.00E-001
 Delta:-6.44E-005

The Marker reading is shown on the left side of the graph.

- 4 Click the **marker readout** button on the top left corner to see the detailed marker readout.



Markers	Time	Voltage	BER
Upper Right:	-2.325 UI	371.9mV	5.000E-001
Lower Left:	-3.325 UI	-72.47mV	5.000E-001
Delta:	1.000 UI	444.4mV	-8.054E-008

How to Run the Mask Measurement?

To run the Mask Measurement, the Eye Diagram measurement must be running.

- 1 Click on the **Mask** tab
- 2 Click **Load** button

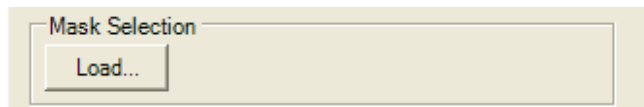

- 3 Select a Mask File.

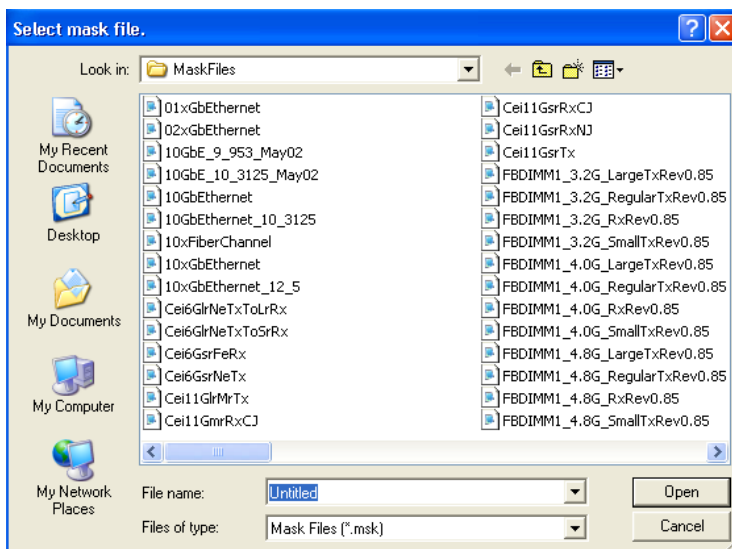

- 4 Select a Mask Alignment.

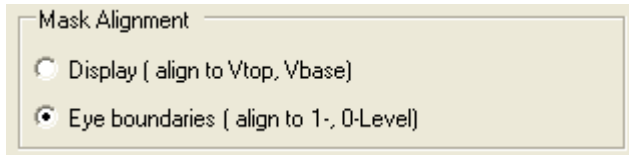

5 Start

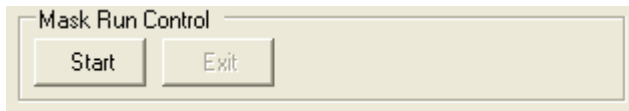

This starts the Mask Measurement. You also have options for setting Mask Margins, and Mask Scaling.

6 Click the **mask readout** button on the bottom left of the screen to either see, or close the detailed mask readout.



Region	Standard	Worst Ber hit	Margin(100%)
1	3.8720K	5.000E-001	1.5910K
2	0	4.727E-001	449.00
3	880.00	5.000E-001	3.5200K
Total hits	4.7520K	5.000E-001	5.5600K
Total Waveforms	382.20M		

How to Customize Mask Files

A Mask file can be modified as per requirements. Following are the sections in a mask file:

Mask File Identifier

The mask file identifier is the first line in a mask file. If the identifier string is missing or incorrect, the file will not be loaded and an error dialog box will be displayed.

`MASK_FILE_N49xxx`

Mask Title

The mask title is a quoted string of up to 15 characters. The title is displayed on the mask readout when the file is loaded.

Example to Mask Title:

`"2xGB Ethernetaa"`

Region Number

The region number is an integer that defines a mask violation area (or polygon).

You can specify 1 to a maximum of 3 regions in a mask file.

Example to Region Number:

```
/* Region Number */ 2
```

Region Type

You can define three types of regions for each region number you have specified:

- STD defines the actual mask region.
- MARGIN_MAX defines the maximum margin area when test margins are set to 100%.
- MARGIN_MIN defines the minimum margin area when test margins are set to -100%.

Example to Region Type:

```
/* Region Type */ STD
```

```
/* Region Type */ MARGIN_MAX
```

or

```
/* Region Type */ MARGIN_MIN
```

Number of Vertices

The number of vertices is an integer that specifies the quantity of X and Y coordinates needed to define a mask region or polygon.

Example to Number of Vertices:

```
/* Number of vertices */ 4
```

X and Y Coordinates

These are the floating-point numbers that define the locations of the mask polygon vertices for each region and region type defined in the mask file. Mask Files use a relative coordinate system based on an eye diagram's zero level, one level, and crossing point parameters.

Example to X and Y Coordinates:

```
+0.0, +1.0
```

Mask Setup

You can list various remote commands in the mask setup area to define the relative vertical and horizontal positions of the 0 and 1 coordinates of the mask X and Y-axes. Commands listed in the setup area are executed as part of the mask data load process.

Example to Mask Setup:

```
:MTES:SCAL:YTRACK OFF
```

```
:MTES:SCAL:Y1 -0.65
```

```
:MTES:SCAL:Y2 +0.65  
:MTES:SCAL:XDEL 312.5E-12  
:MTES:AMET NRZEYE  
:MTES:INP:MODE DIFF
```

In the above example, the Y1 and Y2 values define the mask with an absolute voltage value. In some mask files, Y1 and Y2 values are not specified, and so the voltage value is relative to either Vtop and Vbase, or to the eye boundaries specified by the user in the GUI.

A mask can be set in two modes, either differential, or single. The above example, ":MTES:INP:MODE DIFF", sets the mode of the mask file to differential. The mask mode, when defined, should match the mode set in 'ED Input Setup Dialog'. In case it doesn't match, an error message will indicate this mismatch.

How to Enter Notes?

There is a tab on the top left corner of the graph for entering notes.

To enter notes:

- 1 Click on the **Note Tab**.



- 2 Enter your notes in the drop down text box. This gives the timestamps of the comments entered. It's a scrollable editor where your latest comments are entered at the end.



How to Save and Recall

To Save the following measurements:

- Eye Diagram
- Property Page
- Legend States
- Left Panel Values
- Automated Eye Parameter Measurement

1 Click on the **Analysis** Menu

2 Click on '**Save Measurement**'

Eye Diagram
 Output Timing
 Output Levels
 Error Location Capture
 Fast Eye Measurement
 Spectral Jitter
 Eye Opening
 Save Measurement...
 Load Measurement...
 Export Data... |

To Recall the measurements:

1 Click on the **Analysis** Menu

2 Click on '**Load Measurement**'

Eye Diagram
 Output Timing
 Output Levels
 Error Location Capture
 Fast Eye Measurement
 Spectral Jitter
 Eye Opening
 Save Measurement...
 Load Measurement...
 Export Data... -

How to Export Fetched Data?

You can export various counters to an exported file location.

1 Click on **Analysis** Menu

2 Click on 'Export Data'

- Eye Diagram
- Output Timing
- Output Levels
- Error Location Capture
- Fast Eye Measurement
- Spectral Jitter
- Eye Opening
- Save Measurement...
- Load Measurement...
- Export Data...

When you click on 'Export Data' the following screen appears:

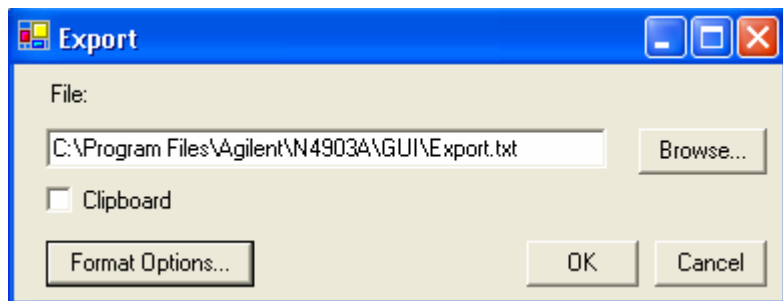

The Clipboard option saves the data on a clipboard.

The 'Format Options' takes you to the following screen.

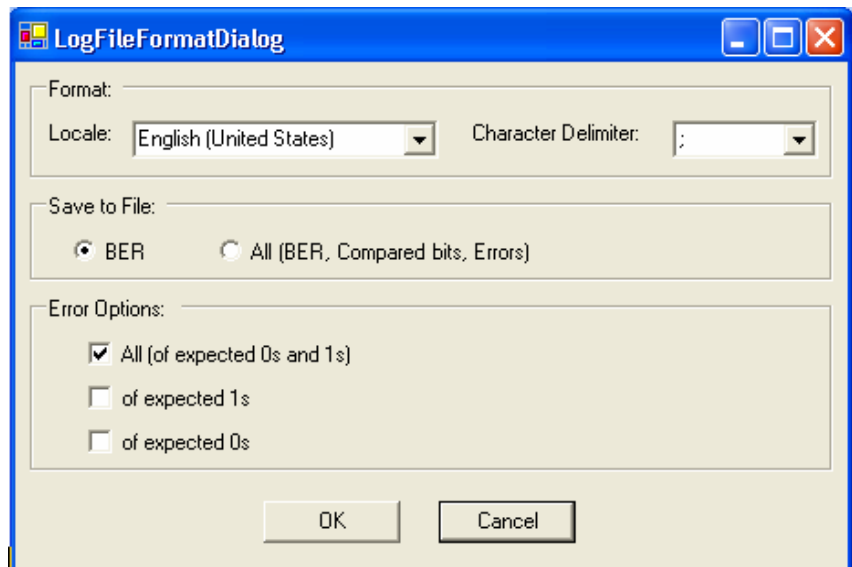

You can select the 'Format', 'Save to File' and 'Error Options' as per requirements.

The 'Save to File' option specifies, either saving only the BER values, or saving the BER, the Compared Bits, and the Errors.

The 'Error' option gives the user the choice of saving, the BER, the Compared Bits, and the Errors, for different combinations of expected 1s, 0s, and all.

Eye Diagram - Reference

The Eye Diagram measurement returns the results in graphical and numerical forms. The following section explains the measured parameters, and the displayed options that are specific to these measurements. Additionally, some information is provided to explain the theoretical background to these measurements.

Parameters that can be set on the various tabs of the *Properties* pop-up:

Parameters

NOTE

If the parameters on this page are modified, run the measurement again to update the results. While the measurement is running the parameter settings cannot be changed.

Persistence Set the criteria for Persistence.

- Infinite

With 'Infinite', the eye appears with the Automated Eye Parameter Measurement, and the results keep on improving in accuracy, as more number of points get measured and represented on the diagram along with the deeper BER values. The BER threshold in the Graph Tab decides how long the measurements will be done at the boundaries of the eye. Once the measured points exceed the BER Threshold defined by the user, the measurement is done deep inside the eye.

This is a default setup for persistence.

- Minimum

With 'minimum', a reasonably clear eye, with transition, appears along with all the Automated Eye Parameter Measurement, and automatically the measurement restarts showing only the refined eye diagram. To stop the measurements click the abort button.

- Secs

With 'Secs', the measurement runs for the specified time, and automatically the measurement restarts showing only the refined eye diagram. To stop the measurement, click the abort button.

Center to Sets the transition of the eye on the plot

- Middle of eye

With 'middle of eye', the center of the eye coincides with the center of the screen.

- Transition

With 'transition', the transition of the eye coincides with the center of the screen.

Number of eyes Set the criteria for the number of eyes.

- 1.5ui

This option displays '1.5' eyes on the graph. The transitions of the complete eye are placed such, that, they show '0.25' eyes on both sides. So, the total number of displayed eyes is 1.5.

- 2ui

This option displays '2.0' eyes on the graph. The transitions of the complete eye are placed such, that, they show '0.5' eyes on both sides. So, the total number of displayed eyes is 2.0.

View

Calculate Measurement Parameters Set the criteria for calculating the eye width, eye height, JPP, JRMS, cross voltage according to the BER threshold selected.

- 0 Errors

To see '0 errors' select the option. This gives the results according to the last measured contour for the current measurement. This is more significant in the case of deep BERs.

- BER Threshold

Enter the BER threshold at which the five results, eye width, eye height, JPP, JRMS, and cross voltage, will be calculated.

The show checkbox displays the contour at which the results are calculated.

Transition Time Set criteria for transition time

- 10/90

Measures horizontal scan from 10% to 90% of the signal amplitude.

- 20/80

Measures horizontal scan from 20% to 80% of the signal amplitude.

Eye Boundaries Set the criteria for eye boundaries. Total is 100% of the display screen. These are applied for the level related parameters, for example, 0-level, 1-level, Signal to Noise ratio, Eye Amplitude, and so forth.

- Left Boundary

Marks the lower edge of the eye window boundary

- Right Boundary

Marks the higher edge of the eye window boundary

Eye Width/Height Set the criteria for eye width and eye height.

- Eye width at crossing point

This parameter gives the eye width at the crossover. Total is 100% of the display screen.

- Eye width custom

This parameter gives the eye width at a specific percent of the eye amplitude. (Starting from low level to high level).

- Eye height

This parameter gives the eye height at a specific percent of 1ui. (Starting from left to right).

Table Number format Set the criteria for the decimal placing in the return values.

- Decimal Places

This parameter sets the decimal placing for the Automated Eye Parameter Measurement.

Optical Parameters Set the criteria for the optical parameters. These are used to convert level values to optical power values.

"power value" = ("level value" - "dark level") * "conversion gain"

- Dark Level

Internally generated offset signals.

- Conversion Gain

Is used to convert voltage level into power.

Power Unit • dBm

Output will be displayed in dBm.

$$\text{power value[dBm]}=10*\log(\text{power value[W]}/1mW)$$

- W

Output will be displayed in Watt

Extinction Ratio Unit Set the criteria for the Extinction Ratio Unit

- Ratio

Ratio of two optical power levels, low level and high level

- dB

Unit for measuring the extinction ratio.

$$\text{ratio[dB]}=10*\log(\text{ratio})$$

- %

Extinction Ratio in percentage

Graph

Timing Units Set the criteria for the Timing Units:

- Unit Interval

Unit used to measure delay relative to the eye width.

- Seconds

Unit used to measure eye width in absolute terms of time.

Waveform Set the criteria for the waveform:

- Show Waveform

This option shows the waveform graphic.

- Smooth Waveform Graphic

The smooth waveform gives a finer waveform output. It logarithmically interpolates between the measured points to give a finer waveform.

- BER Threshold

The BER Threshold value allows the user to measure around the eye boundaries first, and then, deeper inside the Eye for BERs beyond the specified threshold.

Contour Set the criteria for the Contour:

- Show Contour line

This option plots the contour.

- Show Legend

This shows the list of BER values.

Grid

- Show Grid

The 353pxl X 289pxl screen is divided into a 10 X 8 grid. This parameter adds a grid to the screen.

Markers Set criteria for the markers:

- Show Marker Lines

This option enables the markers on the screen.

- Reset marker

This brings the marker back to its default position.

Mask

Mask Selection

- Load Mask File

With Load, a mask file is loaded. Once the file is successfully loaded the Start button gets activated.

Mask Alignment Set Mask Alignment:

- Display

The Display mode aligns the mask using the Vtop and Vbase values of the displayed waveform. All the threshold coordinates of the mask will be relative to this voltage. This is the default mode for mask alignment.

- Eye Boundaries

The Eye Boundary mode aligns the mask using the 1 level and 0 level of the waveform. The 1 level and the 0 level are calculated between the Eye Boundary 1, and Eye Boundary 2.

Mask Margins Set Mask Margins:

- Margins on

Mask Margins, allows the user to enlarge or shrink a mask in order to see the margin size, and how much of it is violated. The maximum and minimum margins are defined within the mask files.

Mask Scaling Set Mask Scaling

With mask scaling the mask can be manually enlarged, shrunk, and moved around. With the logic levels track selected, the mask regions are bound together, and move together with a fixed amplitude. Position (pos) gives the timing displacement, and dT gives the delta time offset.

Mask Run Control Set Mask Run Control:

The Mask Run Control aligns the mask, switches it on, starts displaying the number of waveforms, and the number of mask violations per mask region, and the worst BER per Mask region.

Exit stops the computation, hides the mask, and the violations.

Automated Eye Parameter Measurement

Automated Eye Parameter Measurement

Table 26

S.No	Parameter	Description
1	Rise time	Measures the mean transition-time taken by the data on the rising edge of the eye diagram. The data crosses three thresholds: lower, crossover point, upper and the eye transition. Note: Rise time is dependent on the Transition Time of the View Tab. The two options are 10/90 and 20/80.

Table 26

S.No	Parameter	Description
2	Fall time	<p>Measures the mean transition-time taken by the data on the falling edge of the eye diagram. The data crosses three thresholds: lower, crossover point, upper and the eye transition.</p> <p>Note: Fall time is dependent on the Transition Time of the View Tab. The two options are 10/90 and 20/80.</p>
3	Sample Count	<p>The number of points measured for the eye diagram. If persistence, 'infinite', is enabled, the value will gradually increase.</p>
4	0-Level	<p>Zero level is the measurement of the mean value of the logical 0 of an eye diagram.</p> <p>Note: This measurement is made in a section of the eye referred to, as the eye window boundaries. The default value for the NRZ eye window is the central 20% of the bit period. You can change the eye window boundary settings in the Configure Measurement dialog box. These settings determine what portion of the eye will be measured.</p>

Table 26

S.No	Parameter	Description
5	1-level	<p>One Level is a measure of the mean value of the logical 1 of an eye diagram.</p> <p>Note: This measurement is made in a section of the eye referred to, as the eye window boundaries. The default value for the NRZ eye window is the central 20% of the bit period. You can change the eye window boundary settings in the Configure Measurement dialog box. These settings determine what portion of the eye will be measured.</p>
6	Eye Amplitude	<p>The difference between the logic 1 level and the logic 0 level.</p>
7	Eye Width	<p>The horizontal measurement of the eye opening at a specified BER Threshold.</p> <p>Note: The Eye Width is calculated according to the BER Threshold set in the View Tab. Eye Width is calculated as per the selection of either Width at Crossing Point or Custom defined Width.</p>

Table 26

S.No	Parameter	Description
8	Eye Height	<p>Measures the vertical opening of an eye diagram with respect to BER threshold. This determines "eye closure" due to noise.</p> <p>Note: The Eye Height is calculated according to the BER Threshold set in the View Tab. Eye Height is calculated with 'Height at' in the View tab.</p>
9	Jitter P-P	<p>Full width of the histogram at the eye crossing point with respect to BER threshold.</p> <p>Note: The Jitter P-P is calculated according to the BER Threshold set in the BERT from Calculate Measurement Parameters of the View Tab.</p>
10	Jitter RMS	<p>A standard deviation of the crossing point histogram with respect to BER threshold.</p> <p>Note: The Jitter RMS is calculated according to the BER Threshold set in the BERT from Calculate Measurement Parameters of the View Tab.</p>

Table 26

S.No	Parameter	Description
11	Cross Voltage	<p>Crossing percentage is a measure of the amplitude of the crossing points relative to the 1 level and 0 level.</p> <p>Note: The Cross Voltage is calculated according to the BER Threshold set in the BERT from Calculate Measurement Parameters of the View Tab.</p>
12	Signal to Noise Ratio	<p>In signal-to-noise, the "signal" is the information power of the signal indicated by the difference between the '1', and '0' level. The "noise" is the combined standard deviations of the '1' level spread, and the '0' level spread.</p>
13	Extinction Ratio	<p>Extinction ratio is the ratio of the 1 level power and the 0 level power of an eye diagram.</p> <p>Note: The Extinction Ratio is calculated using the Dark Level and Conversion Gain of the View Tab.</p>
14	OMA	<p>The Optical Modulation Amplitude (OMA) is the difference between the 1-level power and 0-level power.</p> <p>Note: The OMA is calculated using the Dark Level and Conversion Gain of the View Tab.</p>

Table 26

S.No	Parameter	Description
15	Duty Cycle Distortion (DCD)	This value is the difference between the period of a 1 bit and a 0 bit.
16	Average Power	The mean of level 0 power and the level 1 power. Note: The Average Power is calculated using the Dark Level and Conversion Gain of the View Tab.

Eye Diagram Screen

This graph gives the picture of the Eye Diagram Screen.

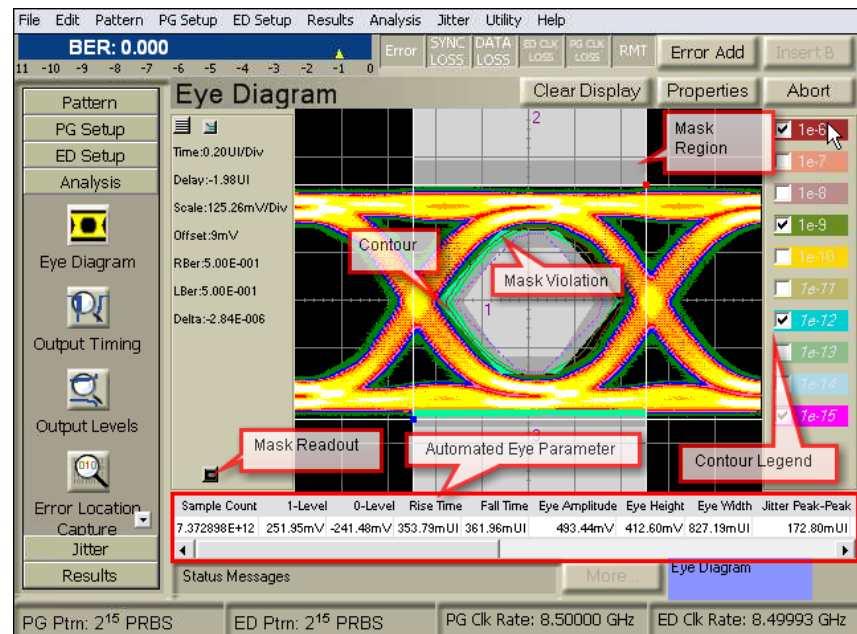

Spectral Jitter

Spectral Jitter - Concepts

The Spectral Jitter measurement allows you to analyze the jitter inherent in the output signals of your device under test (DUT) as a function of the frequency. This measurement can be used for investigating the behavior of the DUT, for example to identify crosstalk effects.

Spectral Jitter Analysis

The Spectral Jitter measurement provides a method for investigating the spectrum of the jitter, that means, its power distribution over frequency.

Deterministic jitter can be caused by repetitive data patterns. It can also be caused by internal or external periodic effects.

The Spectral Jitter measurement detects even small periodic components that may be hidden in a high level of random noise. It informs you about the frequencies of such components and measures their contribution to the total jitter.

This helps to identify jitter sources and to reduce or eliminate their influence.

Prerequisites for Using the Spectral Jitter Measurement

It is important that the initial sampling point is in optimum position (which means, in the middle of the eye opening), because the Spectral Jitter measurement derives its starting sampling point from that point.

See also [“General Requirements” on page 160](#).

How the Spectral Jitter Measurement Works

The Spectral Jitter measurement performs a capture and compare operation in the jitter region. The number of compared and captured bits is adjustable.

By default, the analyzer sampling point is set to an offset of -0.5 analyzer clock periods or unit intervals (UI) from the optimum sampling delay.

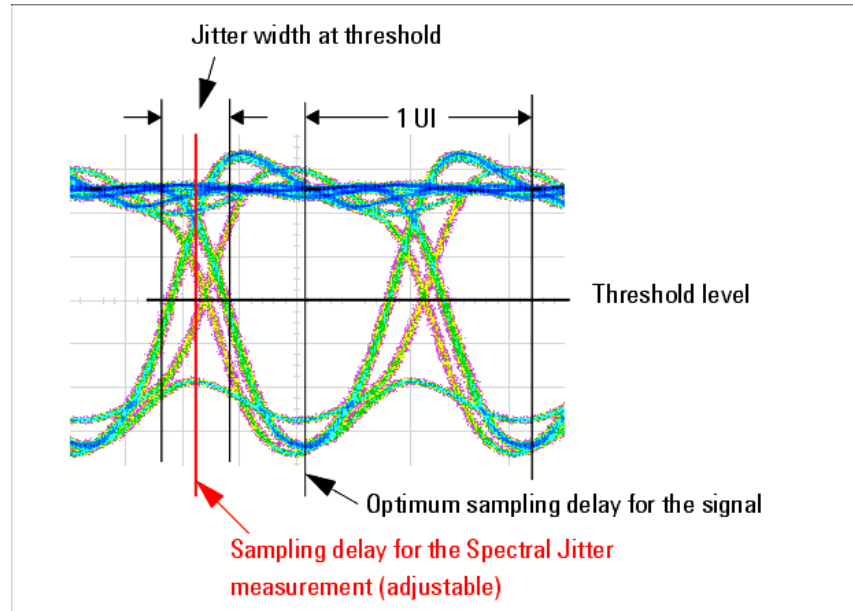

Capture and compare means that a certain amount of incoming data is captured and also compared with expected data in real time. The number of captured data points is adjustable.

While the measurement is running, correct and incorrect data is captured. The resulting records contain the captured data and the corresponding error information.

These records are automatically processed. The error information is subject to a fast Fourier transform (FFT). FFT reveals the spectral components and their power. Several window algorithms are provided to reduce the influence of leakage.

Jitter Distribution Over Time

Jitter has a more or less characteristic distribution over time.

The histogram of pure random jitter shows its Gaussian distribution, as illustrated in the following figure:

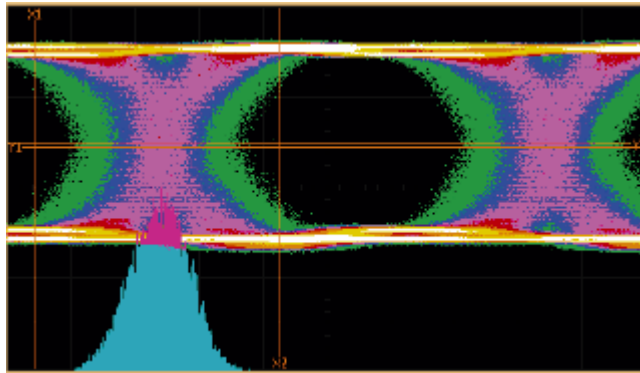

Deterministic jitter periodically adds and subtracts a delay to/from the received signal.

Jitter caused by a square wave or on/off signal has produced the following histogram:

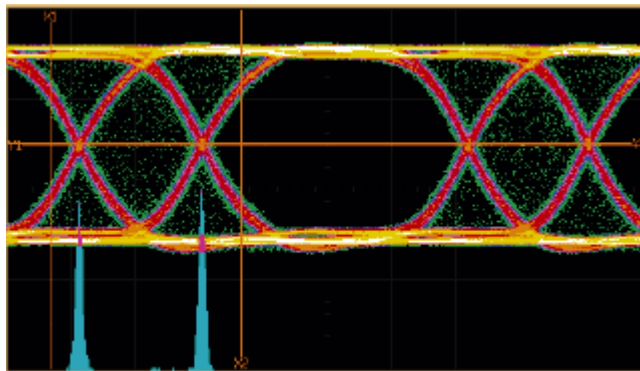

Jitter caused by a triangle signal shows an even distribution:

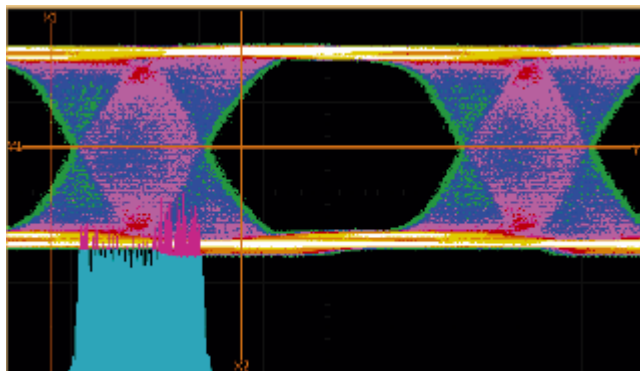

Last, but not least, the histogram of jitter modulated by a sinusoid exhibits two significant peaks:

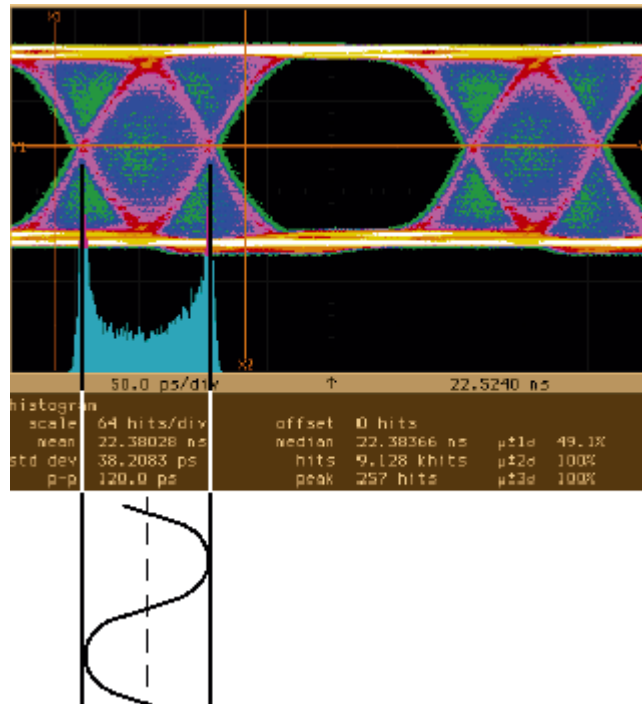

The jitter histogram of a real world signal shows most often a mixture of these characteristic distributions.

Measurement Results

The Spectral Jitter measurement provides:

- A graphical view of power vs. frequency. This makes it easy to identify prominent spectral jitter components. You can adjust the horizontal and vertical axes according to your needs.
- You can switch between linear and logarithmic scales.
- Graphical markers and the zoom function assist you when you are analyzing the graph visually.
- The numerical results include bit error rate, total power, and noise power. They provide also frequency and power information about the dominant peaks in the spectrum.
- Absolute and relative power values are available. Relative values can be normalized to the total jitter power or the power of a selected tone (frequency bin).
- Pass/fail limits can be set for the bit error rate, total power and noise power, and the allowed jitter power in user-defined frequency regions.

Periodic Jitter and Bit Error Information

When the incoming signal is sampled at the transition point, periodic jitter manifests itself in the bit error record. An example may be helpful to understand the phenomenon.

Let us assume we expect and correctly receive a simple 0, 1, 0, 1, 0, ... pulse signal. If we would sample this signal one clock period earlier (-1 UI), we would see a bit error rate (BER) of 1.0. This is the maximum BER for this pattern.

Let us also assume, this signal is overlaid by a periodic jitter source with sinusoidal characteristics.

Now we sample the incoming signal at the transition point (-0.5 UI from the optimum sampling point).

The result is illustrated in the figure below.

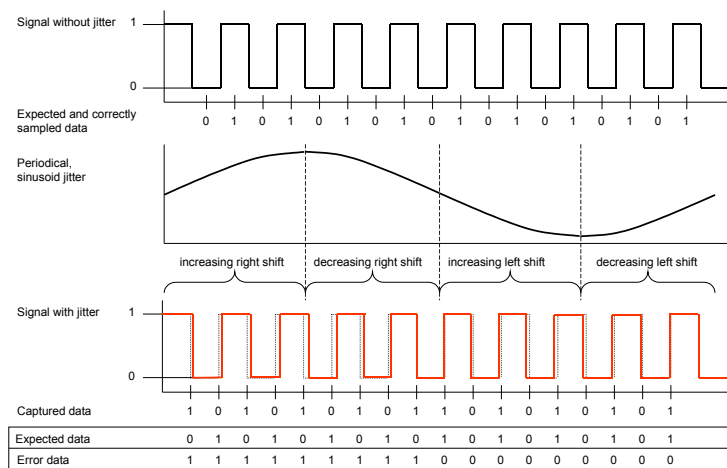

The jitter source moves the received signal to the right and to the left, but the sampling point is fixed (dotted lines show the undisturbed signal). Because we are sampling at the transition point, we get errors when the signal is shifted to the right and no errors when the signal is shifted to the left.

The error signal shows a very characteristic and reproducible pattern. The resulting BER for this kind of signal is 0.5. Other jitter frequencies yield different but also characteristic error patterns and also a BER which is half the maximum BER.

The maximum BER and hence the actual BER are pattern-dependent.

Considering the BER bathtub curve, the sampling point is in the middle of the descending line.

If random data is used, the average bit error rate at the left-hand side of the jitter region is 0.5.

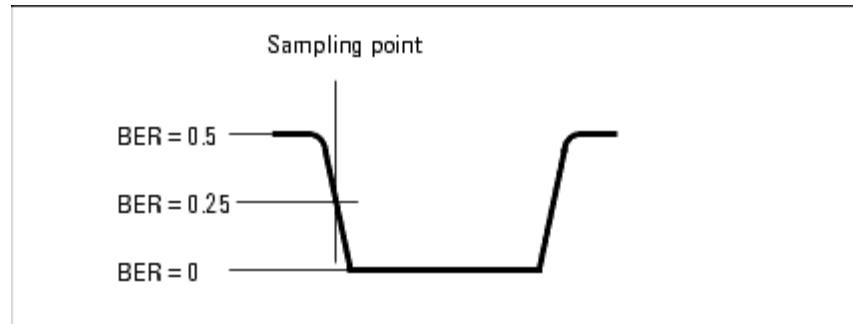

The bit error rate at the right-hand side of the jitter region is 0. We therefore expect a bit error rate around 0.25.

NOTE

The Spectral Jitter measurement should only be used in conjunction with data that has an equal distribution of ones and zeros over time. Otherwise, the results are hard to predict and may be not reproducible.

Signal Processing

If the error signal is obtained as explained above, an analysis in the frequency domain reveals the absence or presence of deterministic jitter. Dominant frequency components become visible and their contribution to the total jitter can be measured.

The modified error signal is subject to a fast Fourier transformation (FFT).

FFT requires that the data record to be processed has a length that is a power of two (2^n , such as 2^{17} , 2^{18} , 2^{19} , 2^{20} , and so on).

From that data record, the FFT calculates pairs of frequency/power values. The number of pairs is half the number of samples. If you have chosen a record length of 2^{17} (which means 131,072 bits or 128 Kbit), the result contains 65,536 pairs. The maximum frequency is half the data rate used for the test.

The results are displayed in the Spectral Jitter measurement graphical and numerical result window.

About FFT

For general information about the Fourier transformation and the special characteristics of the fast Fourier transform, please refer to the standard literature. For details, see the following documents:

- Frederic J. Harris, "On the use of Windows in Harmonic Analysis with the Discrete Fourier Transform", Proceedings of the IEEE, Vol. 66, January 1978
- "The Fundamentals of Signal Analysis", Agilent Application Note 243, Publ. No. 5952-8898E
- "Fibre Channel - Methodologies for Jitter Specifications", National Committee for Information Technology Standardization (NCITS), T11.2/Project 1230/Rev. 10, June 1999
- Yi Cai, Bernd Laquai, Kent Luchman, "Jitter Testing for Gigabit Serial Communication Transceivers", IEEE Design and Test of Computers, Jan-Feb 2002

FFT results The error record contains a bipolar, rectangular signal. If such a signal is periodic, you can expect a spectrum as illustrated below.

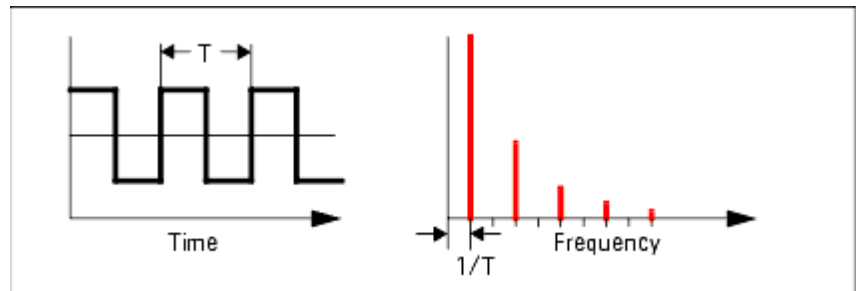

The fundamental frequency and its harmonics appear.

Such spectra have been measured with the Spectral Jitter measurement.

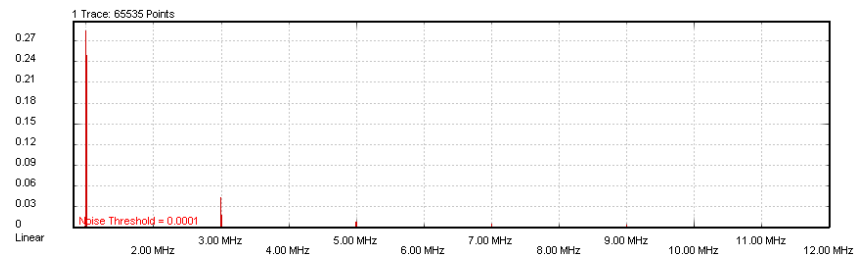

A logarithmic power scale shows the details:

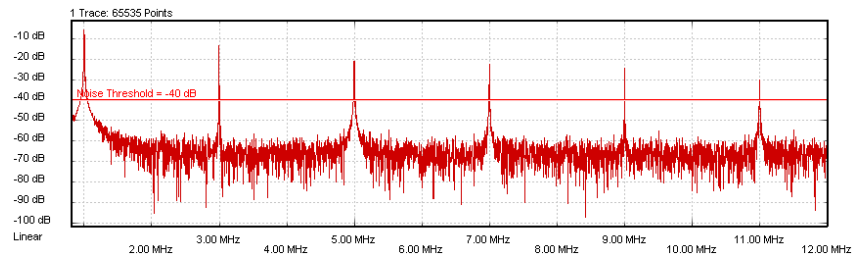

When the repetition period of the characteristic pattern in the error record increases, you will also find the typical sine-x-over-x decay of the spectral power.

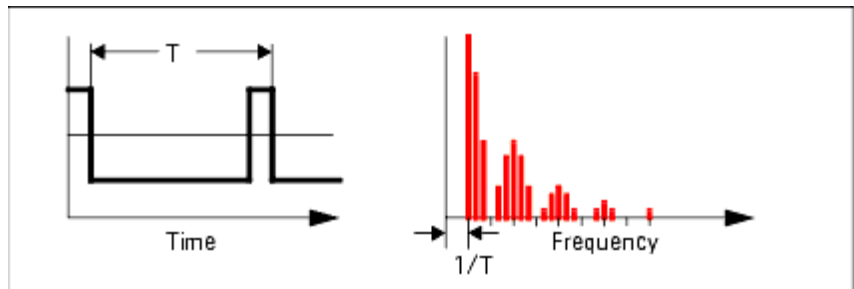

Leakage and Windowing

FFT assumes that the time record contains a representative section of an endless periodic signal. It assumes that time records can be seamlessly concatenated. If this is not the case, a phenomenon called leakage occurs.

Leakage makes it impossible to detect minor adjacent spectral components. The following two figures refer to a slightly disturbed sine wave.

The Appearance of Leakage

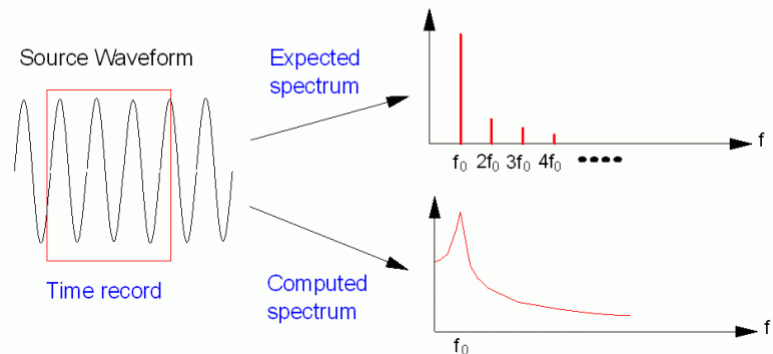

When you perform a Spectral Jitter measurement, it is likely that some degree of leakage occurs. The measurement therefore provides a choice of FFT windows that allow you to detect leakage and to reduce its impact.

An FFT window is a filter that sets the beginning and end of the time record smoothly to zero. Such records can be seamlessly concatenated.

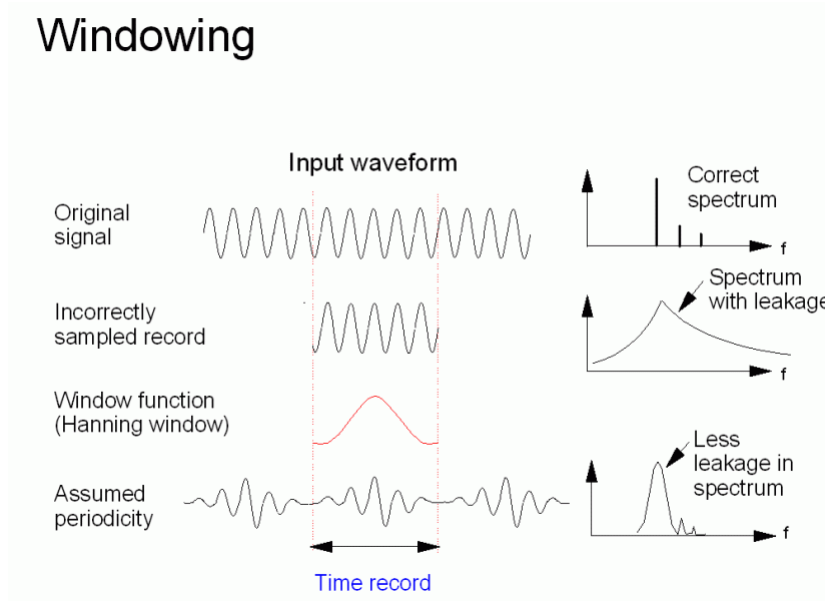

When you are using a window, please note:

- No window removes leakage completely.
- Every window reduces the spectral power.
- Results obtained from different devices can only be compared if the same window is used.

Spectral Jitter - Procedures

This section shows how to set up and use the Spectral Jitter measurement. As an example, we measure the spectral jitter behavior of a shielded cable.

This requires the following steps:

- [“How to Prepare the Spectral Jitter Measurement” on page 287](#)
- [“How to Execute the Spectral Jitter Measurement” on page 287](#)

How to Prepare the Spectral Jitter Measurement

To use the Spectral Jitter measurement to test a shielded cable:

- 1 Disable the pattern generator outputs by pressing the **0V (Disable)** button in the **PG Output Setup** screen.
- 2 Use a shielded cable to connect the pattern generator's Data Out port and the error detector's Data In port.
- 3 Terminate all non-connected pattern generator output ports with 50 Ω .
- 4 Enable the pattern generator outputs by pressing the **0V (Disable)** button.
- 5 Switch to the **Pattern** menu and press **Pattern Select**. Select an appropriate pattern, for example a pure $2^{15}-1$ PRBS, for both the pattern generator and the error detector.
- 6 For the pattern generator setup, you need to specify the logic levels and the bit rate. Select:
 - Logic levels: **LVPECL**
 - Clock speed: **Gb Ethernet** (1.06250 G b/s)
 See “[Setting up the Pattern Generator - Concepts](#)” on page 69 for more information.
- 7 Set up the error detector so that the input range and the termination matches the pattern generator's levels. Select **Normal** as the **Active Input**, an **Input Range** of 1-3V, and set the **Data Termination** to 1.3V.
- 8 Also make sure that the error detector derives its clock from the incoming data stream using Clock Data Recovery. See “[Clock Setup - Procedures](#)” on page 121 for details.
- 9 Press **Sync Now** and then **Auto Align** to find the optimum sampling point. Check that the synchronization and the alignment were successful. None of the error indicators should show red, and the resulting BER should be zero.

How to Execute the Spectral Jitter Measurement

To run the Spectral Jitter measurement:

- 1 Switch to the **Analysis** area. If the **Spectral Jitter** screen is not yet displayed, press the **Spectral Jitter** icon.
- 2 Press the **Start** button to execute the measurement.

The measurement software runs the measurement and displays the results. A total of 65535 points are displayed for this measurement.

Numerical values are also displayed. The values include **Bit Error Rate**, **Total Power**, and **Noise power**. Additionally, you can also configure up to 16 frequency/power pairs. The latter are sorted according to descending power contents. These results are discussed in “[Explanation of the Numerical Results](#)” on page 192.

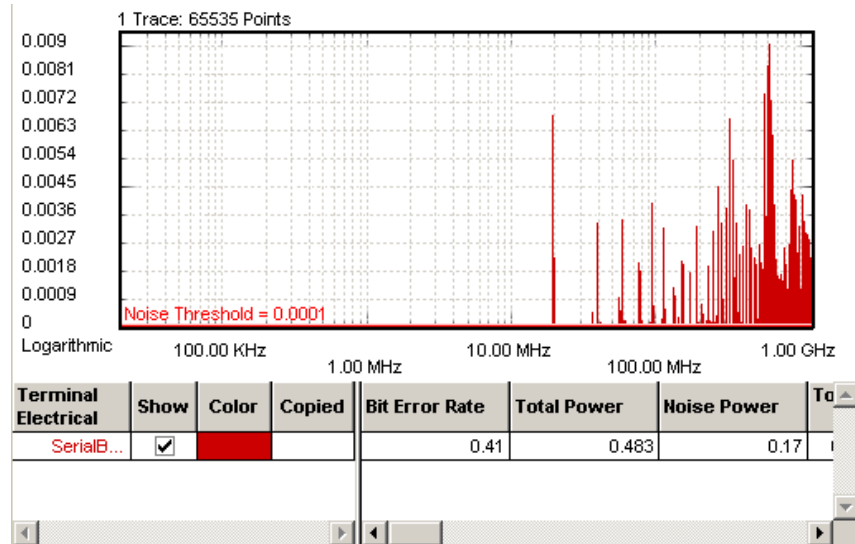

How to Optimize the View of the Results

After you have run a measurement, the resulting graph and the calculated numerical values are displayed. To improve the results, you can change the measurement parameters:

- 1 Press the **Properties** button to open the **Properties** dialog box.
- 2 Use the different tabs in this dialog box to make the required settings:

- **Parameters** tab

These settings are used for data collection. Changes require to run the test again. See “[Parameters Tab](#)” on page 184 for details.

- **Pass/Fail** tab

These settings determine whether the calculated results are recognized as passed or failed. However, a new test run is not required when doing changes here. See “[Pass/Fail Tab](#)” on page 186 for details.

- **View** tab, **Graph** tab, and **Color** tab

All settings on these tabs only affect the way the data is displayed. You do not need to run the measurement again. See “[View Tab](#)” on page 188, “[Graph Tab](#)” on page 190, and “[How to Change the Colors of the Graph](#)” on page 164 for details.

- 3 Press **OK** when you have made all required changes to close the **Properties** dialog box.

Spectral Jitter - Reference

The Spectral Jitter measurement returns the results in a graphical and in a numerical form. The following sections provide explanations of the measured parameters and the display options that are specific to this measurement. Additionally, some information is provided to explain the theoretical background behind the jitter calculations.

Properties that can be specified on the various tabs of the **Properties** dialog box:

Parameters Tab

NOTE

If you modify the parameters on this page, you have to rerun the measurement to update the results.

Set the data acquisition parameters:

- **Acquisition Depth**

Suitable numbers can be chosen from the drop-down list.

The **Acquisition Depth** determines the length of the time record used for the FFT.

A smaller number reduces the duration of the Spectral Jitter measurement and its precision. A larger number increases the measurement duration but also the frequency resolution of the measured spectral components.

The frequency resolution of the measurement is:

$$\text{data rate} / \text{Acquisition Depth}$$

For example: If you have a data rate of 2.5 GHz and an **Acquisition Depth** of 128 Kbit, the frequency resolution is 19.0735 kHz.

The relations are illustrated in the following figure:

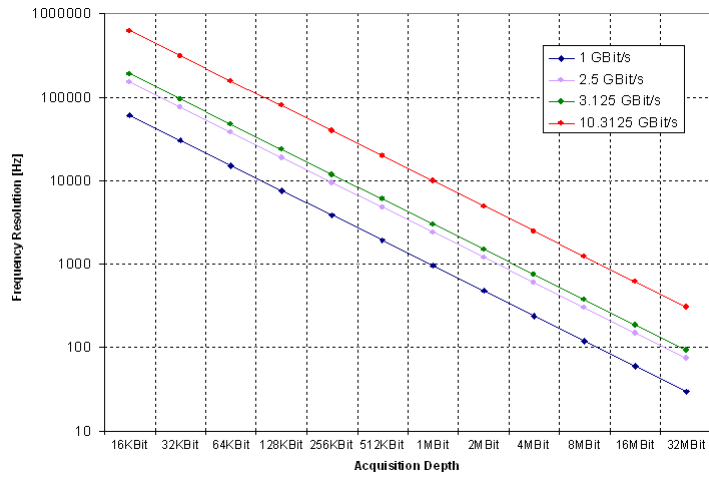

NOTE

A high **Acquisition Depth** requires a high degree of computational effort and hence time.

- **Sample Point Offset**

By default, the sampling point for the measurement is positioned 0.5 clock periods or UI ahead of the present analyzer sampling point.

If the sampling point is set in the middle of the eye, this corresponds to the transition point of the incoming signal. If you have set the sampling delay manually, this is the time offset from that point.

This option allows you to fine-tune the sampling point. The unit is UI (unit intervals). This makes the setting independent of the present clock frequency.

Set the FFT window for the **FFT Calculation**. The following windows are provided:

- Uniform
- Hanning (sometimes also called Hann)
- Hamming
- Blackman

The "uniform" window is no window at all. This setting supplies the original error record to the FFT.

The other windows have the shapes illustrated in the figure below:

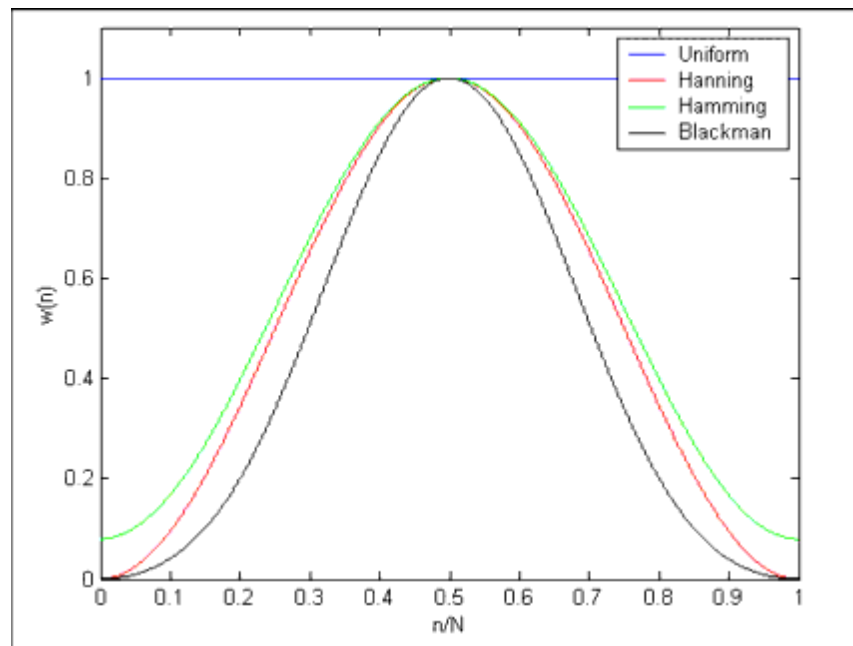

You can see from the figure that the Blackman window is the strongest filter.

The windows are based on the following formulas:

Uniform	$w(n) = 1.0$
Hanning	$w(n) = 0.5 \cdot \left(1 - \cos\left(\frac{2\pi n}{N}\right) \right)$
Hamming	$w(n) = 0.54 - 0.46 \cdot \cos\left(\frac{2\pi n}{N}\right)$
Blackman	$w(n) = 0.42 - 0.5 \cdot \cos\left(\frac{2\pi n}{N}\right) + 0.08 \cdot \cos\left(\frac{4\pi n}{N}\right)$

NOTE

In case of leakage, FFT windows improve the spectral resolution. FFT windows generally reduce the measured spectral power.

For an introduction to FFT windows see [“Leakage and Windowing”](#) on page 285.

Pass/Fail Tab

The **Pass/Fail** tab of the **Properties** dialog box allows you to specify the criteria to decide whether the DUT passes or fails the test. You can change pass/fail criteria without rerunning a test. The software only uses the criteria to rate the results of a measurement.

NOTE

The pass/fail criteria do not control measurement execution. The measurement run will be completed even if the measurement fails for one or more of the criteria.

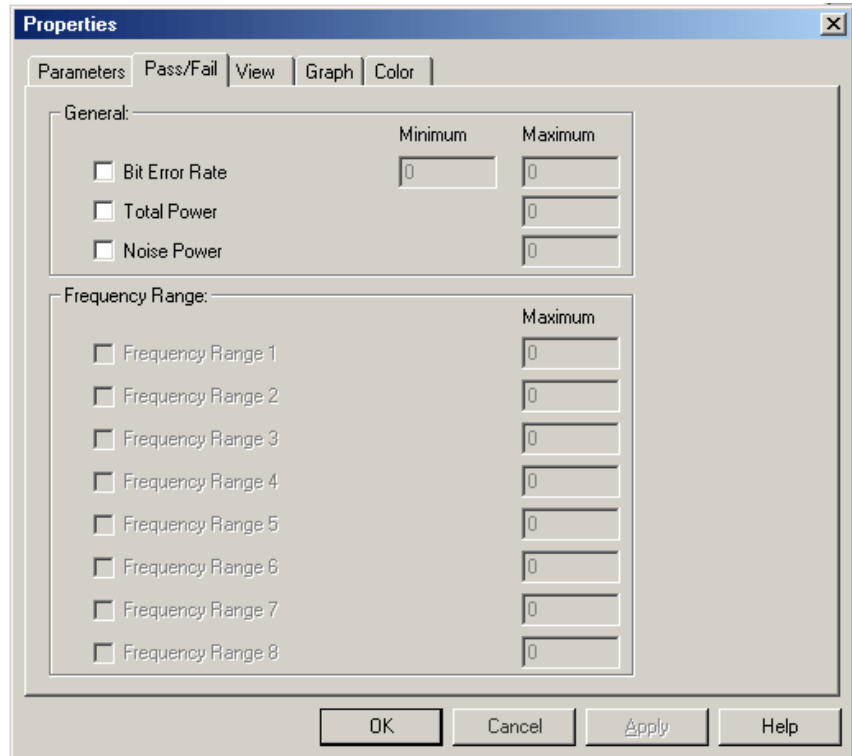

The following **Spectral Jitter Pass/Fail** criteria can be selected for the pass or fail decision:

- Bit Error Rate
- Total Power (in dB)
- Noise Power (in dB)

You can also define the pass/fail criteria for each of the defined frequency ranges.

In the tabular view, each of the calculated values will be marked with an



icon if it failed the test.

The following illustration shows a Spectral Jitter measurement that has failed the criterion for the Bit Error Rate.

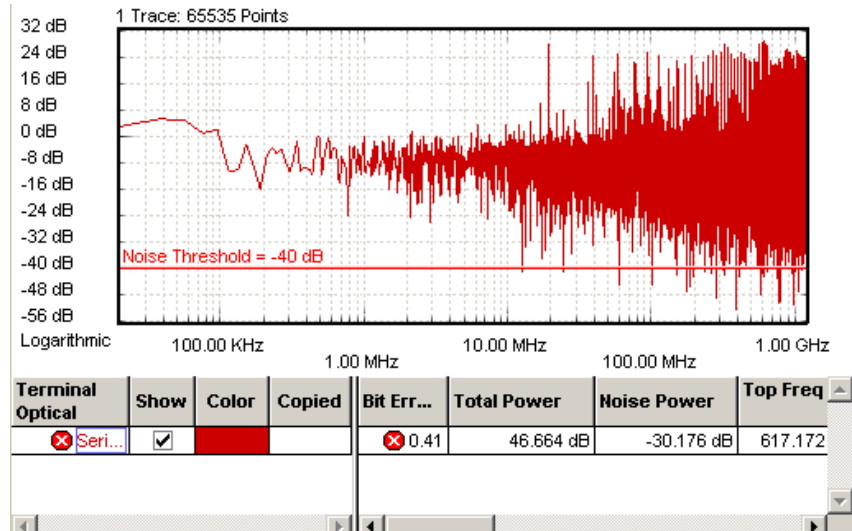

View Tab

The graph shows the noise versus frequency. The **View** tab provides you with various options for analyzing the data and setting frequency ranges for evaluation.

Power scale The linear power scale is well suited for identifying large peaks in the spectrum.

The View tab allows you to change the power scale from linear to dB. The dB scale is a logarithmic scale. The dB scale allows you to examine the whole power range.

The following figure shows an example of a double logarithmic display.

5 Advanced Analysis

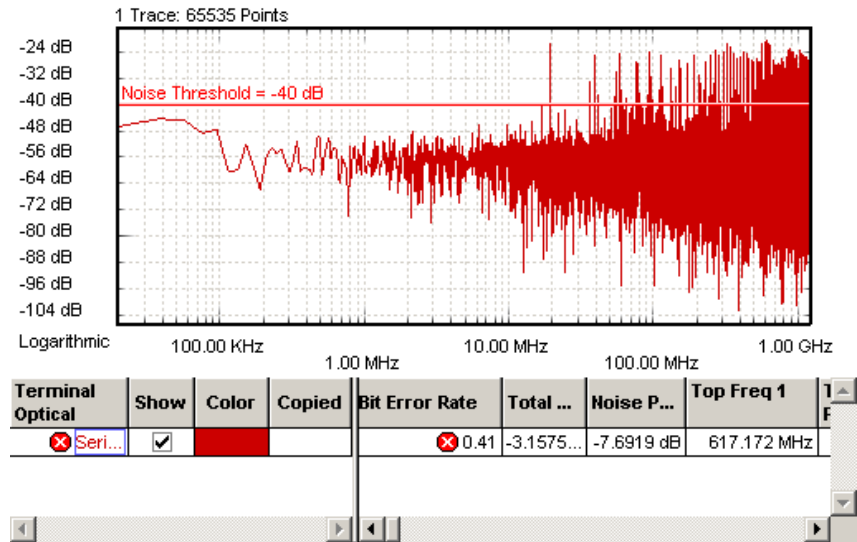

Absolute vs. relative values

The figure above shows the absolute power scale and values as calculated by the FFT. You can also calculate relative values.

Relative values can be normalized to either the total power (**True Relative**) or to the power of a selectable frequency bin (**Relative**).

The following figure shows an example where the scale and the power values have been normalized to the power measured at 1 MHz.

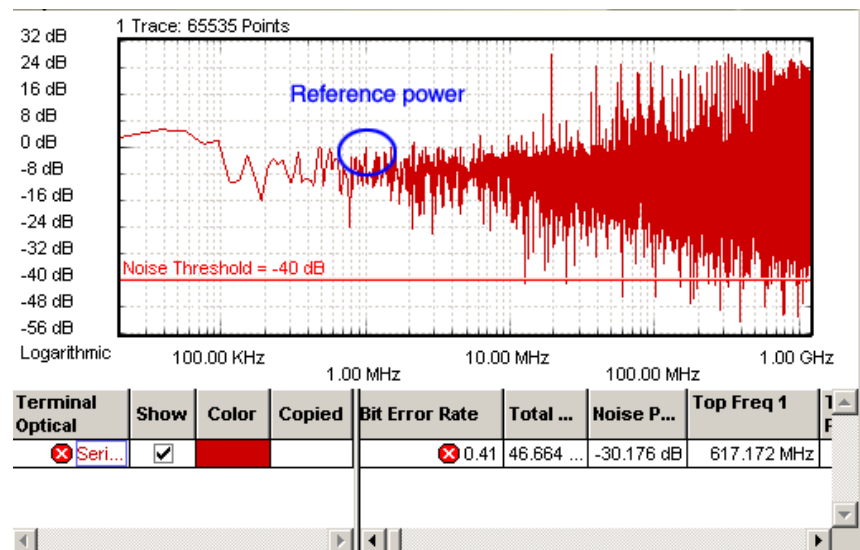

When you set the power values to relative, this changes not only the graphical scale but also the calculated results. You can thus calibrate the power values to any reference.

Noise Threshold The **Noise Threshold** can be moved with the mouse (or your finger). It can also be set on the **View** page of the **Properties** dialog.

This threshold is used to separate between total power and noise power. All components below the **Noise Threshold** are considered noise. When the threshold is changed, the calculated **Noise Power** values change.

If desired, change the **Number of Top Frequencies to Show**. This determines the number frequency/power pairs in the numerical section. Up to 16 pairs can be calculated and displayed.

Graph Tab

On the **Graph** tab, you can use the several options to optimize the graphical display according to your needs.

Frequency Scale Choose between logarithmic and linear scale for displaying the frequencies.

Power Unit Display the power either in a logarithmic (dB) or linear scale.

Frequency Axis Range Show the entire frequency range or zoom in one part of it.

Markers To analyze the graphs at a particular point, you can use the markers. Additionally, you can display all related values for the markers in the marker readout.

Pressing the **Reset Markers** button will set the markers back to the default positions.

Zoom Several zoom factors are available. When you show the zoom graph, you can also allow the zoom graph to track the mouse (or your finger, if you are working directly on the Serial BERT).

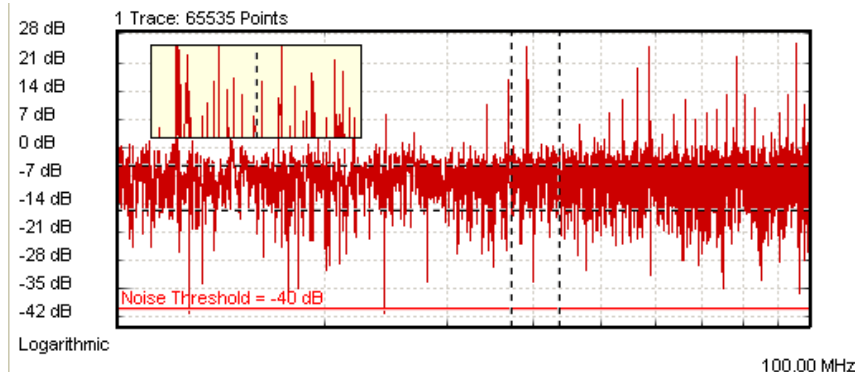

Explanation of the Numerical Results

The measurement provides numerical results for:

- Bit Error Rate
- Total Power
- Noise Power
- The Frequency and total power for up to the 16 frequencies with the highest total power.

You can set the number of top frequencies to be evaluated in the View tab (see [“View Tab” on page 188](#) for details).

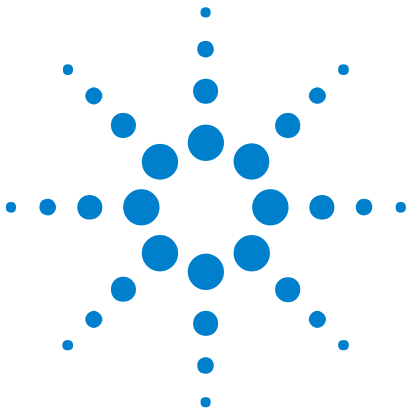

6 Evaluating Results

Evaluating Results - Concepts

The Serial BERT offers several different kinds of tests that can be run:

- Instantaneous Measurements

This type of measurements is used to monitor the instantaneous BER during measurement setup, experiments, and adjustments.

- Accumulated Measurements

This type of measurements is used to measure and log error performance over time. Also, you can capture the location of bit errors for further analysis.

- Eye Measurements

This type of measurements is used to measure the eye height and width of the incoming data signal at specific alignment BER thresholds. This information is displayed on a representation of an eye diagram.

Instantaneous Measurements

Instantaneous Measurements - Concepts

With instantaneous measurements, you can directly view the current BER on the screen. In order to stress your device under test, you can then, for example, add errors to the data stream or switch between different patterns and view the resulting BER. Or you can adjust the output port parameters or the error detector's sampling point while the measurement is running and watch the resulting BER immediately.



Such measurements can be used to find out the benchmark data, for example, for a device prototype.

Test Methods

You can analyze the behavior of your device by employing several test methods. If the changes in the test setup affect the BER, you can immediately notice it on the screen. The resulting changes in the BER let you learn about the DUT's behavior and limitations. Some examples of modifications that you can make are listed below.

- Add errors to the data stream. See [“Error Addition/Insertion - Concepts ” on page 99](#) for details. You can, for example, perform a confidence test of your measurement setup. The analyzer should recognize all errors that you add. If it does not, you may have a problem with your measurement setup. See [“Setup Problems - Concepts” on page 375](#) for details.
- Use alternating patterns to switch between different data streams. For example, if your device is designed to turn off in response to a high BER, you can check if your device behaves as expected. And you can observe what the BER is prior to data loss. See [“Pattern Alternation - Concepts ” on page 102](#) for details.
- Manipulate the signal being generated by the pattern generator, as described in [“Setting up the Pattern Generator - Concepts ” on page 69](#).
- Adjust the sampling point to see the effect on the BER. See [“Sampling Point Setup - Concepts ” on page 126](#) for details.
- Make modifications to your device setup.

This can be used to see how changes to your device affect the BER. You can determine what adjustments improve or degrade the BER.

Instantaneous Measurements - Procedures

This section describes how to run, monitor, and analyze instantaneous measurements.

Running Instantaneous Measurements

The Serial BERT's error detector immediately starts calculating the bit error rate as soon as it receives a valid signal at the data ports.

NOTE

Both the pattern generator and the error detector must be correctly set up and connected to the DUT.

To run a BER measurement:

- 1 Check if all the values in the status line are correct: pattern generator pattern and bit rate, error detector pattern and bit rate.
- 2 View the **BER** display in the top left corner of the GUI.

If the measurement is running properly, a certain BER should be displayed here. In most cases the BER is not a constant value but slightly varying over time. If no BER is displayed because there are no errors detected, you can manually insert an error by pressing the Error Add button in the top right corner of the screen.



When inserting an error, the BER should increase for a short time and then return to the initial value.

How to Monitor the BER Results

There are different ways, how you can monitor instantaneous BER values:

- 1 Listen to the BER warning tones. See [“Audio Signals - Procedures” on page 156](#) for details.
- 2 View the **BER Results** window, which is described in [“BER Results Window” on page 300](#).
- 3 View the **BER** bar and errors indicator. See [“Status Indicators” on page 300](#) for details.

How to Analyze the BER Results

>To analyze the behavior of your device, you can do the following modifications to the test setup and monitor the effect on the resulting BER:

- 1 Add errors to the data stream. See [“Manually Inserting Errors” on page 99](#) for details.
- 2 Use alternating patterns to switch between different data streams. See [“Setting Up a Periodical Output” on page 104](#) for details.
- 3 Adjust the parameters of the output port of the pattern generator, as described in [“Setting Logic Levels and Terminations” on page 79](#).

4 Manually move the sampling point. See “How to Set the Optimum Sampling Point Automatically ” on page 129 for details.

5 Make adjustments to your device.

This can be used to see how changes to your device affect the BER. You can determine what adjustments improve or degrade the BER.

Instantaneous Measurements - Reference

This section describes all elements of the **BER Results** window and the various status indicators:

BER Results Window

This window displays the actual (**BER**) or cumulative (**AccumBER**) BER results:

- The **BER** is the current BER, calculated upon a period of 200ms.
- The **AccumBER** shows either the accumulated BER of the current accumulation, or-if no accumulation is running-the results of the most recent accumulation.

This enables you to monitor real-time BER behavior as you do things such as to manually adjust the sampling point, to add errors, or to make adjustments to your device.

Accumulated/Actual Button Click this button to toggle between **BER** or **AccumBER** results.

Error Count/Accum Error Count This area displays the actual error count or cumulative error count.

NOTE

The **BER** bar below the main menu bar also displays the actual BER. You can drag the small yellow alarm threshold mark to change the BER Alarm Threshold.

Status Indicators

BER bar The **BER** bar displays the BER calculated upon a period of 200 ms.



You can drag the yellow alarm threshold mark to change the BER Alarm Threshold.

Error Indicators These indicators inform you about the following errors:

- Bit error in the data stream located
- Loss of pattern synchronization
- Complete loss of data
- Loss of the error detector's clock signal
- Loss of the pattern generator's clock signal



For troubleshooting information, see [“Setup Problems - Concepts” on page 375](#).

Remote Indicator This indicator turns green when the instrument is under remote control.



NOTE

The instrument does not enter the remote lock state if the N4917A Optical Receiver Stress Test Software is running. This is because the Software also remotely controls the J-BERT and we don't want the software to be locked.

Status Messages and More Button Status messages displays a one-line instrument status or error message. Click the **More...** button to open an Error Message dialog box with the complete message. This dialog box also contains a Help button that takes you to the respective section of the Online Help.



Elapsed Indicator This area displays the progress of the current accumulation period. The accumulation period can be changed in the Accumulation Setup dialog box. For more information, see [“How to Run Accumulated Measurements” on page 303](#).



Pattern Types The PG and ED pattern types are displayed here for your reference.



Clock Rates The PG and ED measured bit rates are displayed here for your reference.



PG Clk Rate: 9,3102. MHz ED Clk Rate: 6,8731. MHz

Accumulated Measurements

Accumulated Measurements - Concepts

Accumulation refers to collecting measurement data over a specific period. This can be used to create test scenarios that are reproducible and comparable. Also, you can let tests run over long times and then evaluate the results afterwards. Furthermore, you can use the log files to determine the location of occurring bit errors for further root cause analysis.

NOTE

While accumulation tests are running, you should not modify the measurement setup, as the measured bit errors do not represent the performance of your DUT under real circumstances.

Measurement Period

The period of time can be set by manual start and stop commands, an absolute time setting, or the time it takes to measure a specified number of bits or bit errors. The accumulation period should be long enough to make a statistically valid BER measurement. See [“Test Times and Confidence Levels” on page 15](#) for details.

NOTE

During measurement logging, the Serial BERT logs data in ten-second intervals. Your log file may be missing up to the last ten seconds of data. To avoid this condition, accumulate for 10 seconds longer than desired.

Accumulated Measurements - Procedures

This section describes how to run accumulated measurements and how to analyze the results:

How to Run Accumulated Measurements

To run accumulated measurements:

- 1 Ensure that the instrument is set up correctly and that the error detector is already in synchronization.
- 2 Press the **Accumulation Setup** icon in the **ED Setup** menu to check the settings made for the data accumulation.



See “[Error Accumulation - Procedures](#)” on page 152 for details.

- 3 To begin accumulation, press the **Start Accum** button on the front panel.

This causes the following events:

- If **Prompt for File Name** has been selected during setup, you will be asked to enter a name for the log file before accumulation begins.
- The data display in the **Accumulated Results** window is reset.
- The recording of data to the measurement log file is reset.

How to Stop Accumulated Measurements

If you specified a single or repeat test, the test runs until the specified end condition is reached. If you selected a manual test, it will run until you stop it manually.

- Press the **Stop Accum** button on the front panel to stop the test immediately.

NOTE

Errors are only counted when the signal at the Gate In port is low.

How to View the Results

You can view data from accumulated measurements in several ways:

- 1 Press the **Accumulated Results** icon in the **Results** menu to view the test results.

For easy comparison, the results of the current and previous accumulation are listed here. See [“Accumulated Measurements - Reference” on page 304](#) for details on the reported values.

- 2 Examine the measurement log files on an external PC.

This allows to access all data for detailed processing and analysis on a PC. Also, you can track the status of all indicators (such as DATA LOSS and CLK LOSS) during the accumulation period. If you want to view results from an accumulation period prior to the current and previous test, you can view the respective log file, too.

How to Analyze the Results

Accumulated measurements can help you determine the cause of bit errors. Bit errors can be caused by a variety of problems. In addition, instrument settings can affect how errors are measured and displayed. The sync mode setting has the greatest effect.

- Analyze the basic accumulated results and log files. Possible observations that may occur are:
 - Errors became constant (and remained constant for a period of time) or number of errored 0's was greater than errored 1's, see [“Constant Errors \(More Errored 0's than 1's\)” on page 379](#).
 - Errors were random, see [“Random Errors” on page 380](#).
 - Sync loss seconds were measured, see [“Sync Loss Seconds” on page 381](#).

Accumulated Measurements - Reference

The **Accumulated Results** window presents data from the current and previous accumulation period.

NOTE

Data from the current and all previous accumulation periods is available in the measurement log files, if correctly set up.

This window contains a graph and five tables:

Ratios Graph

This graph displays the delta errored 1's ratio, delta errored 0's ratio, and total delta error ratio at data points over the entire accumulation period. The error ratios on the y-axis are set to a range of 1E+0 (100 % errors) to 1E-12. The accumulation period is on the x-axis.

Display Change During accumulation, data will appear to move from left to right on the ratios graph. When the graph is completely filling the display, the x-axis time scale will double. The data graph is then occupying only half of the display and will continue to move to the right again. This will repeat until the accumulation period has ended.

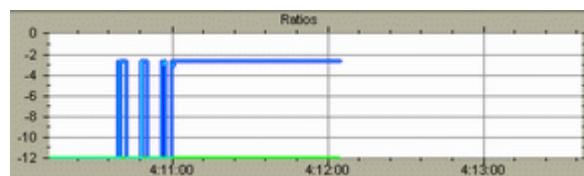
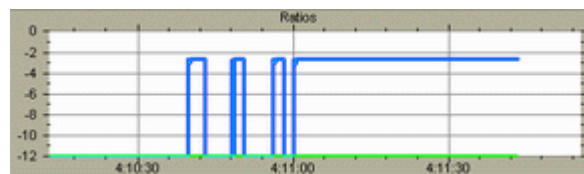

Zooming This graph can accumulate a large amount of data. You can click any point on this graph to zoom into an area of BER data. You can continue to click on the graph until you have zoomed to the maximum. The point you click will appear in the middle of graph. You can press the back button (left arrow) to zoom out again.

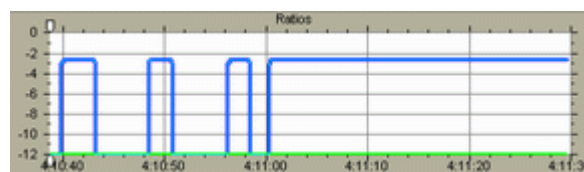
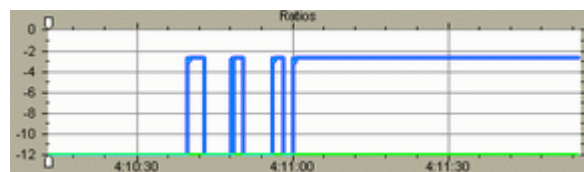

NOTE

The zooming function cannot be used before the accumulation period has ended.

NOTE

To view precise BER data for every point in time, view the measurement log file.

While zoomed in, you can move data left or right by dragging the graph or by using the front panel knob.

Sizing Handles

You can also zoom vertically by dragging the top and bottom sizing handles. The current view can be moved vertically if you click between the handles and drag them up or down.

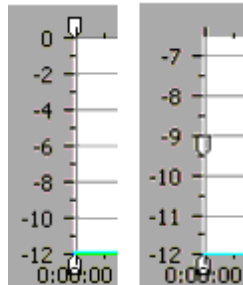

Accumulated Results

In the Accumulated Results table, the following values are listed:

- **Bit Count**

The number of bits considered for the accumulation period is displayed here. This may not equal the total number of bits sent from the PG.

- **Error Ratio**

The ratio of the error count to the bit count is displayed here to 4 significant digits.

- **Error Count**

The number of errored bits measured during the accumulation period is displayed here.

- **Errored 1's Ratio**

The ratio of the errored 1's count to the bit count is displayed here to 4 significant digits.

- **Errored 1's Count**

The number of logic 1's measured as logic 0's during the accumulation period is displayed here.

- **Errored 0's Ratio**

The ratio of the errored 0's count to the bit count is displayed here to 4 significant digits.

- **Errored 0's Count**

The number of logic 0's measured as logic 1's during the accumulation period is displayed here.

G.821 Measurements

- **Availability**

The ratio of the available seconds to the total gating period expressed as a percentage.

- **Unavailability**

The error ratio is calculated over 1 second timed intervals during the gating period. An unavailable period begins when the error ratio is worse than 1×10^{-3} for 10 consecutive seconds. These 10 seconds are considered part of the unavailable time. The unavailable period ends when the error ratio is better than 1×10^{-3} for 10 consecutive seconds. These 10 seconds are considered part of the available time. Percent (%) Unavailability is the ratio of the unavailable seconds to the total gating period expressed as a percentage.

- **Severely Errored Seconds**

The ratio of the total number of available seconds with an error ratio worse than 1×10^{-3} to the total number of available seconds, expressed as a percentage.

- **Degraded Minutes**

Severely errored seconds are discarded from the available time and the remaining seconds are grouped into blocks of 60 seconds. Blocks which have an error ratio worse than 1×10^{-6} are called Degraded Minutes and Percent (%) Degraded Minutes is the ratio of the total number of degraded minutes to the total number of 60 second blocks in the available time expressed as a percentage. Incomplete blocks of less than 60 seconds are treated as complete blocks of 60 seconds.

- **Errored Seconds**

The ratio of the errored seconds in the available time to the total number of seconds in the available time, expressed as a percentage.

Interval Results

- **Error Free Seconds**

The number of seconds in which no errors were measured is displayed here.

- **Error Free Deciseconds**

The number of deciseconds in which no errors were measured is displayed here.

- **Error Free Centiseconds**

The number of centiseconds in which no errors were measured is displayed here.

- **Error Free Milliseconds**

The number of milliseconds in which no errors were measured is displayed here.

- **Errored Seconds**

The number of seconds in which errors were measured is displayed here.

- **Errored Deciseconds**

The number of deciseconds in which errors were measured is displayed here.

- **Errored Centiseconds**

The number of centiseconds in which errors were measured is displayed here.

- **Errored Milliseconds**

The number of milliseconds in which errors were measured is displayed here.

- **Sync Loss Seconds**

The number of seconds in which the error ratio was greater than the sync threshold is displayed here.

Accumulation Parameters

- **Elapsed Time**

The time elapsed during the accumulation period is displayed here.

- **Percent Complete**

For single and repeat accumulation modes, the percentage of the accumulation period completed is displayed here to one decimal

place. For repeat mode, this percentage is recalculated each time the accumulation period repeats.

- **Accumulation Mode**

The type of accumulation mode is displayed here. The mode can be **Manual**, **Single**, or **Repeat**.

- **Accumulation Period**

For single and repeat accumulation modes, the accumulation period is displayed here. The period will be displayed in elapsed seconds, error count, or bit count, depending on the selected method.

Burst Results

The recommended application for burst mode is to measure multiple data bursts in quick succession. In this way, you can accumulate data for all bursts together. You may wish to accumulate the number of bits necessary for a statistically valid BER measurement. Refer to [“Introduction to Burst Sync Mode” on page 144](#) and [“Test Times and Confidence Levels” on page 15](#) for details.

When the accumulation period lasts for the duration of all bursts, the gaps in error counting (while the Gate In signal was high) will not be included in BER calculations. The gaps in error counting will not be considered error-free periods.

NOTE

If the gaps between data bursts are greater than 1 second (or 100 ms in the measurement log file), they may be visible in the accumulated results graph.

- **Burst Status**

The following states may be returned:

- No Error

No burst errors have occurred (any of those listed below).

- Gate Signal Too Long

This error can occur if there are too many bits within a burst. The limit is 4 Gbit. At 13 Gb/s, this occurs roughly after 0.3 s (slower frequencies have a higher gate-in period). This error has a higher priority than "no unique 48bits".

- No Unique 48 Bits Found

For reliable synchronization, a pattern must contain a unique 48-bit pattern (the detect word). If the current pattern does not have a detect word, this error occurs.

If this status occurs, the synchronization may be incorrect, as could also be the measured bit error rate. There are standard patterns that may contain more than one instance of the used detect word. Statistically, every other burst would be correctly synchronized.

In this case, it is recommended that you redefine the pattern. This error can only occur with memory-based patterns.

- Unknown

The status is unknown. This can occur if accumulation has not been started, or if Burst Sync mode has not been activated.

- **Burst Sync Ratio**

Percentage of time in burst (while the Gate In signal is low) that patterns are in sync and error counting is active. A higher percentage is desirable, because it indicates that more data is measured during each burst.

$$\text{Burst Sync Ratio} = \frac{\text{Bit Count Time}}{\text{CDR Settling Time} + \text{Synchronization Time} + \text{Bit Count Time}}$$

- **Total Burst Count**

Total number of bursts received while in burst mode during the accumulation period.

- **Bad Burst Count**

Total number of bursts where sync is never achieved during the accumulation period.

- **Bit Count**

The number of bits considered for the accumulation period is displayed here. This may not equal the total number of bits sent from the PG.

Eye Measurements

Eye Measurements - Concepts

The purpose of eye measurements is to measure the eye height and width of the incoming data signal at specific alignment BER thresholds. This information is displayed on a representation of an eye diagram.

Eye Measurements - Procedures

Eye measurements are made each time the **Auto Align, Clock/Data Center**, or **0/1 Threshold Center** functions are used.

To analyze the results:

- 1 View the graph and table in the **Eye Results** window.

This window provides detailed information on the calculated eye. See [“Eye Measurements - Reference” on page 311](#).

- 2 Analyze the results by observing changes in the eye results due to the following adjustments:

- Make changes to your device or measurement setup.
- Run auto-search functions at different BER thresholds.

This will allow you to see the eye margin at specific BERs and construct basic eye contour information.

- 3 Change the sampling point in the **Sampling Point Setup** window. See [“Sampling Point Display” on page 135](#) for details.

Eye Measurements - Reference

Eye results are displayed for the **Current Align** and **Previous Align** process. They are also graphically displayed on a representation of an eye diagram.

Eye Width and Height

Eye width is the inside horizontal opening of the data eye in an eye diagram. This measurement is made by the error detector after an **Auto Align** or **Data Center**. The eye width at the current 0/1 decision threshold is displayed on a simulated eye diagram. The left and right eye edges are determined by the user-defined BER threshold. Different BER thresholds will produce different eye width results.

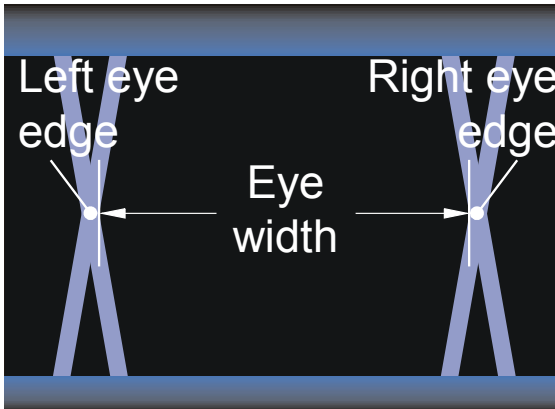

Eye height is the inside vertical opening of a data eye in an eye diagram. This measurement is made by the error detector after an auto align or 0/1 threshold center. The eye height at the current data input delay point is displayed on a simulated eye diagram. The upper and lower eye edges are determined by the user-defined BER threshold. Different BER thresholds will produce different eye height results.

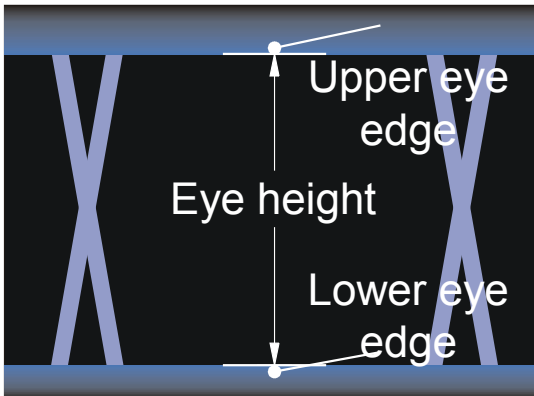

NOTE

Most oscilloscopes measure eyes differently, using statistical data. Therefore, the eye results of a Serial BERT and an oscilloscope may be different.

The table in the top half of the Eye Results window additionally lists the following values:

- Eye Voltage Center
One of two components of the sampling point, the 0/1 decision threshold (eye voltage center) is displayed here.
- Eye Data Input Delay
One of two components of the sampling point, the data input delay is displayed here.

- Alignment Threshold

The alignment BER threshold is displayed here. This threshold was used to define the eye edges and the above eye results.

- Delta Error Ratio

The BER measured during the previous 200 ms is displayed here.

6 Evaluating Results

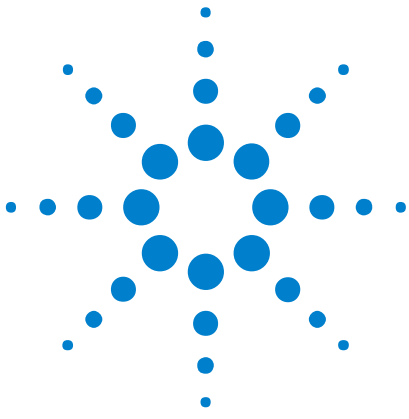

7 Jitter Tolerance Tests

Jitter Tolerance Tests - Concepts

NOTE

This chapter refers only to Serial BERT instruments on which the calibrated and integrated jitter injection option J10 is installed.

A jitter tolerance measurement is used to determine the ability of a device or system to maintain communication quality in the presence of jitter. It comes in two varieties:

- Jitter Tolerance Characterization determines the jitter levels where the device under test can no longer maintain a desired bit error ratio (BER).
- Jitter Tolerance Compliance verifies that the device under test is able to maintain a BER level at pre-defined jitter levels and jitter frequencies, as defined by a standard.

The basic setup of a jitter tolerance test is illustrated below:

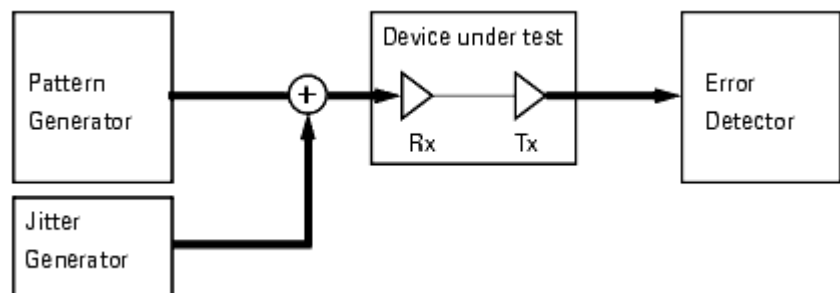

Understanding Jitter Tolerance

The behavior and the passed/failed classification of data receiving devices or circuits are determined by their ability to withstand

- Jitter
- Intersymbol interference
- Level noise

This refers particularly to the performance of phase-locked loops (PLLs) or clock data recovery circuits (CDR).

Jitter tolerance can be measured by applying a distorted data signal to the DUT and measuring the resulting bit error ratio. To make jitter tolerance tests reproducible, the signal distortion must also be reproducible. This requires some definitions.

Jitter

Receivers react differently on

- different types of jitter
- the jitter composition
- the jitter frequency spectrum
- the combination of jitter frequencies and data rate

Various test standards specify the jitter composition to be used for jitter tolerance tests.

The Serial BERT provides the following means for generating artificial (reproducible) jitter:

- Two voltage-controlled signal delay lines
- A phase shifter for modulating the generated clock

For more information see

- [“Understanding the Types of Jitter” on page 317](#)
- [“How the N4903 Generates Jitter” on page 321](#)

Intersymbol Interference

Conductors on PC boards have a limited bandwidth. This causes intersymbol interference which changes the shape of the received eye opening. The eye becomes unsymmetrical.

The Serial BERT provides the Interference Channel option J20 to simulate ISI.

For more information see

- [“Intersymbol Interference” on page 320](#)

Level Noise

Level noise affects the voltage amplitude of the eye opening.

The Serial BERT provides the Interference Channel option J20 to simulate level variations by adding sinusoidal interference.

For more information see

- [“Crosstalk” on page 321](#)

PLL Performance Test

Testing a PLL (or CDR) is not complete until the entire frequency range of the PLL has been checked under worst-case conditions.

For this purpose, the Serial BERT provides the Jitter Tolerance Characterization measurement.

For more information see

- [“Jitter Tolerance Characterization - Concepts” on page 338](#)

PLL Standards and Compliance Tests

The Optical Internetworking Forum (OIF) as well as other institutions have proposed standards for testing the performance of data receivers and receiver circuits in the presence of jitter.

For this purpose, the Serial BERT provides the Jitter Tolerance Compliance measurement. This measurement is available as an option (option J12) which can be ordered together with the instrument or retrofitted.

For more information see

- [“Jitter Tolerance Compliance - Concepts” on page 352](#)

Understanding the Types of Jitter

The standards for jitter tolerance tests prescribe combinations of certain jitter types. This section gives an overview of these types.

Random Jitter

Random jitter (RJ) is always present. Resistors, transistors, and other components generate noise that impacts transmitters and receivers. This kind of jitter has a Gaussian distribution over time.

Theoretically, the Gaussian distribution stretches from $-\infty$ to $+\infty$. In practice, the amplitude is defined by the crest factor (p-p amplitude = $\sigma \times \text{crest factor}$)

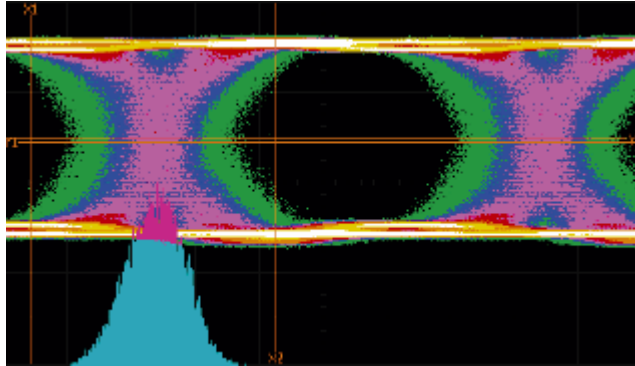

Bounded Uncorrelated Jitter

Similar to random jitter, bounded uncorrelated jitter (BUJ) has also a Gaussian distribution, but this distribution is cut (bounded) at both sides.

This kind of jitter can be caused, for example, by crosstalk on a parallel bus or by intersymbol interference of random or long pseudo random binary bit sequences.

To simulate bounded uncorrelated jitter for jitter tolerance tests, it can be generated from a filtered (frequency-limited) PRBS.

Periodic Jitter

Periodic jitter (PJ) is generally picked up from other periodic sources.

Rectangular Jitter Rectangular jitter may be caused, for example, by a switching power supply. It has a distribution as shown below.

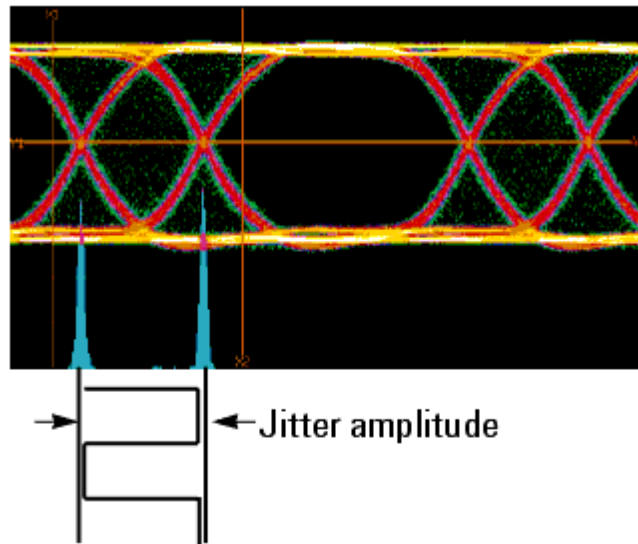

The jitter amplitude is usually specified in UI. One UI (Unit Interval) is always the reciprocal of the present data rate. For example, if the data rate is set to 2 Gbit/s, one UI corresponds to 500ps.

Sinusoidal Jitter This kind of jitter can be picked up from any adjacent signal or clock. The jitter histogram has a U-shape.

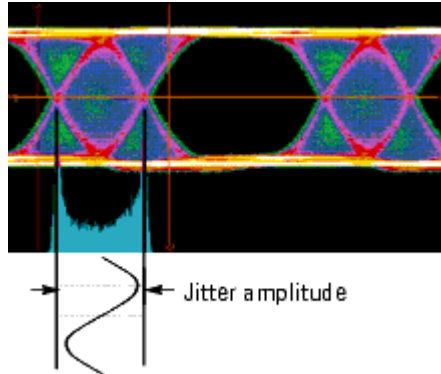

Triangular Jitter Triangular jitter is always generated by a spread spectrum clock but can also be caused by other periodic sources. Triangular jitter has a uniform jitter distribution.

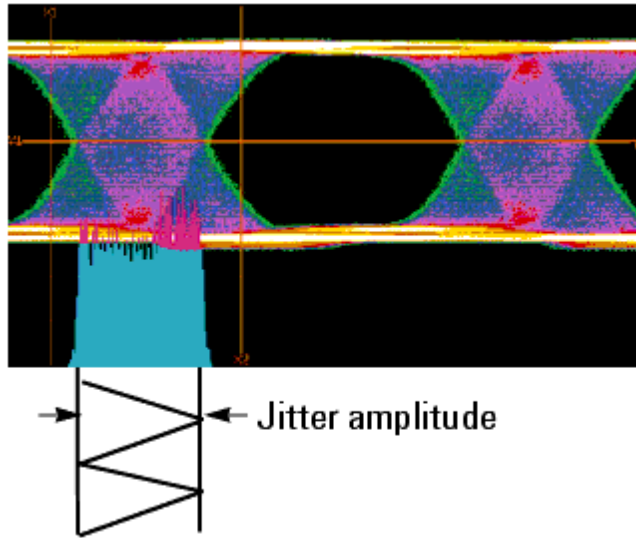

Intersymbol Interference

Intersymbol interference (ISI) is caused by bandwidth limitations of cables and backplanes. It cuts off higher frequencies and hence changes the shape of the eye opening.

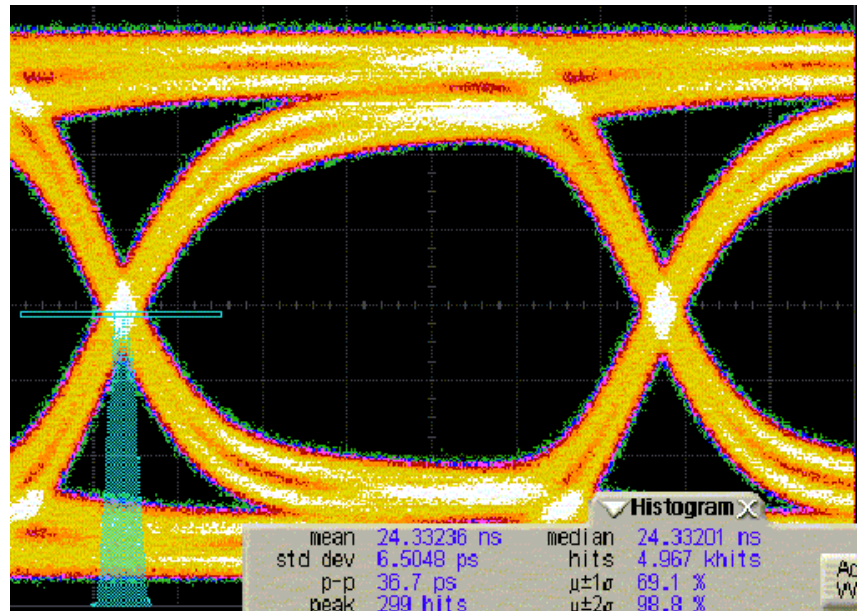

Intersymbol interference can be simulated by inserting a defined transmission path between the pattern generator and the DUT.

Crosstalk

Crosstalk between adjacent signal paths modulates the vertical eye amplitude. This narrows the voltage range of the receiver needed for capturing data correctly.

For jitter tolerance tests, amplitude modulation is most often simulated by modulating the data output with a sinewave signal. This is called Sinusoidal Interference (SI).

Total Jitter

Total jitter is the sum of all kinds of jitter.

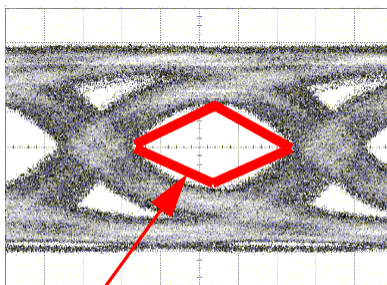

Remaining eye opening in presence of jitter

Edge, level, and shape variations impact width, height, and symmetry of the eye opening. An example is shown below:

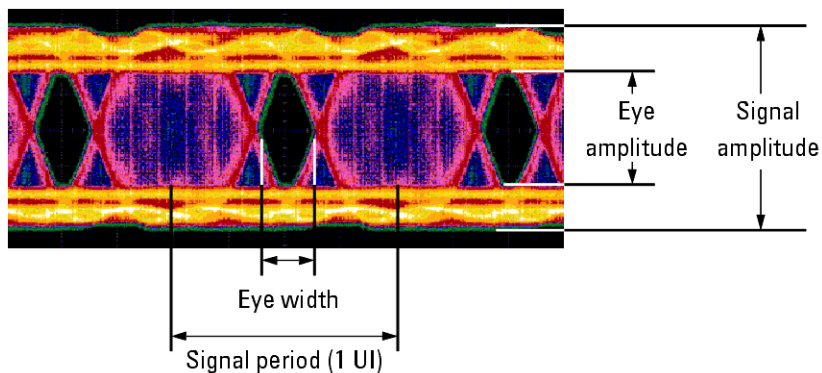

How the N4903 Generates Jitter

An Serial BERT on which the calibrated and integrated jitter injection option J10 and the interference channel option J20 are installed, combines all the necessary jitter sources in one instrument.

Jitter Generation Block Diagram

To support all present test standards, the pattern generator of the Serial BERT has the following hardware architecture:

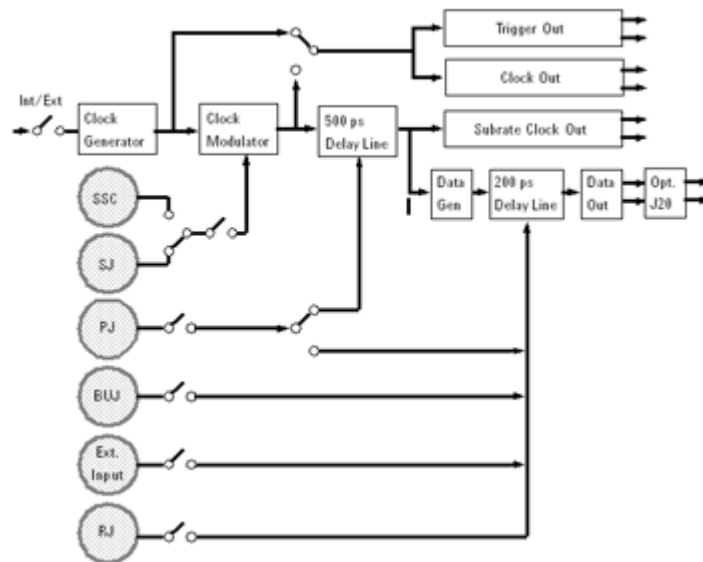

Clock generator The clock can be generated from the internal oscillator or an external source.

Jitter sources The instrument has internal sources for spread spectrum clocking (SSC), sinusoidal jitter (SJ), periodic jitter (PJ), bounded uncorrelated jitter (BUJ), and random jitter (RJ). In addition, an external jitter signal can be applied at the Delay Ctrl Input.

Note that all these sources can be individually switched on or off.

Clock modulator This is a special modulator that modulates the generated clock with a low-frequency signal. The resulting jitter superimposes all other jitter components.

Two sources are provided for modulating the clock: Spread spectrum (triangular) or sinusoidal. Only one of them can be used at a time.

When sinusoidal modulation is chosen, the Clock Output and Trigger Output ports can be connected to the unmodulated or the modulated clock. If SSC is enabled, the Clock Output and Trigger Output ports provide the spread spectrum clock.

NOTE

The two delay lines will be longer than 200ps and 500ps respectively, but the final value is instrument dependent.

Delay lines Two delay lines are provided for generating data jitter, a 500+ps delay line and a 200+ps delay line. Considering the data output, they are connected in series.

The 500+ps delay line is provided for generating large jitter amplitudes at low bit rates. It cannot be used for bit rates higher than 3.37Gbit/s.

The source for periodic jitter (PJ) can be connected to the 500+ps delay line or to the 200+ps delay line.

All other sources can only be connected to the 200+ps delay line.

Subrate clock The Subrate Clock Output follows the 500+ps delay line. It is not influenced by any jitter produced by the 200+ps delay line.

Interference Channel

The option J20 Interference Channel is available for simulating intersymbol interference (ISI) with or without sinusoidal interference (SI).

This is a hardware module that can be plugged into the instrument. It has two ports, P1/P1 and P2/P2. Both can be connected single-ended or differentially.

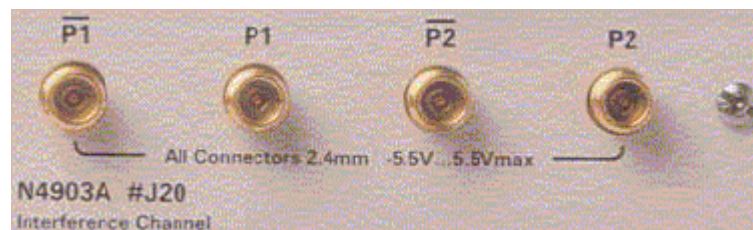

The Interference Channel provides a switchable signal path with Nelco 4000-6 FR4 characteristics. This path can be connected between the pattern generator's Data Out port and the DUT. For instructions refer to [“Connecting the J20 Option” on page 407](#).

The Interference Channel provides also a sinewave generator and a resistive combiner. This makes it possible to add sinusoidal interference (amplitude modulation) to the data signal.

The Interference Channel is built up as shown in the following figure.

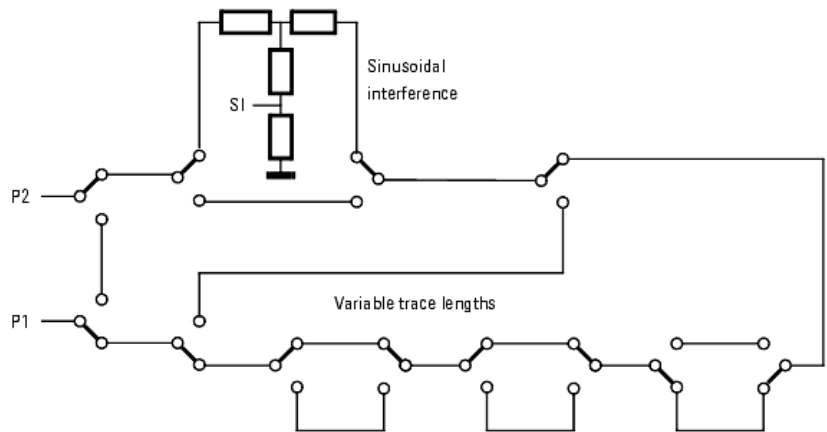

The figure above shows the connections for a single trace segment combined with sinusoidal interference.

NOTE

Note that all these relays and traces exist twice to support single-ended and differential operation.

When intersymbol interference is switched off, there is a minimum trace length between P1 and P2.

ISI must be enabled if sinusoidal interference shall be added to the signal. In this case, the minimum trace is longer (refer to the technical specifications).

Data can be input by connecting the pattern generator's Data Out port to either P1 or P2.

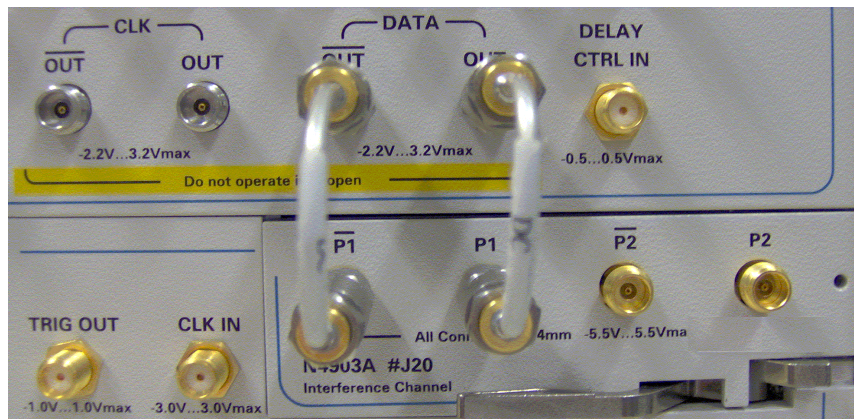

If P1 is used as input, sinusoidal interference is (or can be) added after the signal has passed the chosen trace. Seen from the DUT, this is called "near end" injection. If P2 is used as input, sinusoidal interference is (or

can be) added at the beginning of the trace. This is called "far end" injection.

Jitter Setup

Jitter Setup - Concepts

The **Jitter Setup** function is used for composing the total jitter in a defined and calibrated way.

This function reflects the present setup of the Serial BERT's internal jitter generation hardware (see also "[Jitter Generation Block Diagram](#)" on page 322).

The display is divided into two sections:

- Delay line status and switch area
- Overview and setup area

Delay Line Status and Switch Area

The switch is a button that can be pressed. It switches the periodic jitter source to either the 500+ps or the 200+ps delay line.

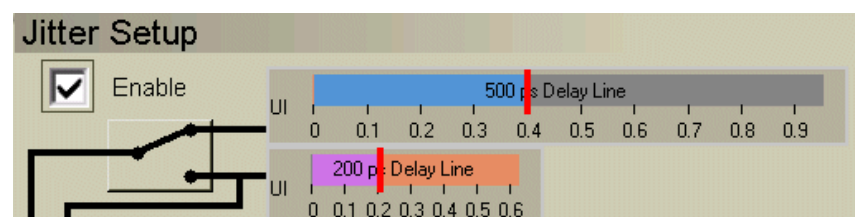

The delay lines show markers which indicate the used and the remaining jitter amplitude in UI. Colored bars allow you to judge the impact of each jitter component on the total jitter.

UI is the acronym for Unit Interval. One UI is the present clock period.

Sinusoidal jitter is not generated by a delay line but by modulating the clock. Sinusoidal jitter cannot be used together with SSC, because both features use the same modulator.

Overview and Setup Area

Five colored rows keep you informed about the present jitter composition of:

- Random jitter
- External jitter source (connected to the Delay Ctrl Input)
- Bounded uncorrelated jitter
- Periodic jitter
- Sinusoidal jitter

Overview	Amplitude	Frequency	Auxillary
<input checked="" type="checkbox"/> Random	15.0 mUI	N/A	15.32 mUI total
<input checked="" type="checkbox"/> External	415 mUI	N/A	332 mV
<input type="checkbox"/> Bounded Uncorrelated	100 mUI	1.000 Gb/s	2 ²³ -1, 200 MHz
<input checked="" type="checkbox"/> Periodic	400 mUI	30.000 MHz	Sinusoidal
<input type="checkbox"/> Sinusoidal	10.000 UI	10.00 kHz	Clock Modulated

Each type can be separately turned on or off.

The **Overview** column consists of buttons that can be pressed to change the parameters of each jitter type independently from others.

Jitter Setup - Procedures

Do the following to compose the desired jitter:

- 1 Press the Jitter button on the front panel or, in the **Jitter** window, press the **Jitter Setup** Icon.

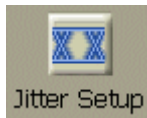

This opens the **Jitter Setup** window.

- 2 Enable jitter generation. Click the respective checkbox.

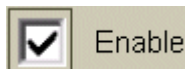

When this checkbox is disabled, no jitter is generated. This refers to all the jitter types shown on the screen, even if they seem to be connected. When this checkbox is enabled, the displayed status becomes active.

NOTE

The **Jitter Enable** checkbox has no impact on SSC. If spread spectrum clocking is enabled (from the **Bit Rate Setup** window of the Pattern Generator), it continues, even if the **Jitter Enable** checkbox is off.

Select the Delay Line

To select the delay line for periodic jitter, press the switch.

**NOTE**

The 500+ps delay line cannot be used for bit rates above 3.37 GHz.

Specify the Jitter Components

To specify the jitter components:

- 1 Activate a jitter source (press its checkbox).
- 2 Click its button in the **Overview** column.



This opens a window to set the parameters. An example for random jitter is shown below.

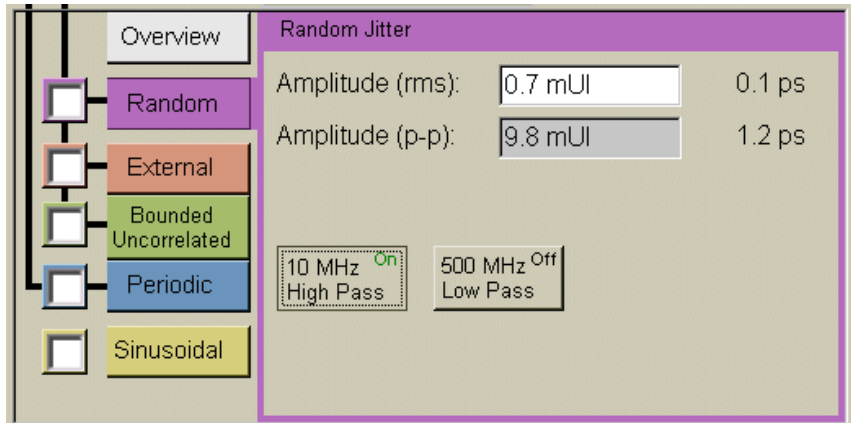

A parameter that must be set for any jitter type is **Amplitude**. This defines the timely width of the jitter component.

- 3 Observe the consumption of delay line capacity indicated by the delay line markers. Ensure that the total jitter remains within the margins of the chosen delay line.
- 4 Return to the overview display by pressing the **Overview** button.
- 5 Proceed with the next jitter type you wish to add.

NOTE

When you activate an **External** jitter source (by pressing its checkbox), you will find that this apparently consumes the whole free capacity of the delay line (at the right-hand side of the red bar).

But this is just an indication. You can still add or change internal jitter components. The external jitter range is automatically updated when you add, change, or switch off one of the internal sources.

Jitter Setup - Reference

The **Jitter Setup** function is used for composing the total jitter in a defined and calibrated way.

Jitter Enable

This checkbox is used enable or disable jitter generation.

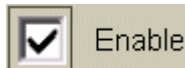

When this checkbox is disabled, no jitter is generated. This refers to the whole composition shown on the screen. When this checkbox is enabled, the present status becomes active.

NOTE

The **Enable** checkbox has no impact on SSC. If spread spectrum clocking is enabled (from the **Bit Rate Setup** window of the Pattern Generator, see “[Spread Spectrum Clock](#)” on page 92), it continues, even if the **Jitter Enable** checkbox is off.

Delay Line Switch

This switch can be pressed to switch the source of periodic jitter to either the 500+ps or the 200+ps delay line.

NOTE

The 500+ps delay line cannot be used for data rates above 3.37 GHz.

Delay Line Display

The delay line display shows red markers that indicate the consumption of delay line capacity by the present jitter setup.

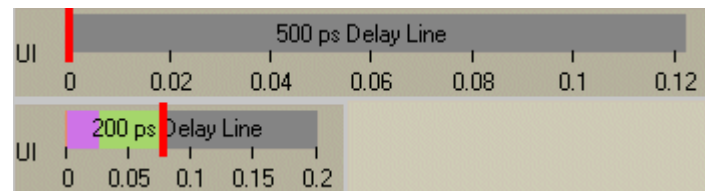

Colored bars indicate the consumption by the various jitter components.

The consumption is shown in UI (Unit Intervals) and is calculated from the present data rate. Because the delay lines have a fixed time capacity, the scales change when the bit rate is changed.

Jitter Composition Overview

This section of the **Jitter Setup** function shows the present jitter composition.

	Overview	Amplitude	Frequency	Auxillary
<input checked="" type="checkbox"/>	Random	15.0 mUI	N/A	15.32 mUI total
<input checked="" type="checkbox"/>	External	415 mUI	N/A	332 mV
<input type="checkbox"/>	Bounded Uncorrelated	100 mUI	1.000 Gb/s	2 ⁿ 23-1, 200 MHz
<input checked="" type="checkbox"/>	Periodic	400 mUI	30.000 MHz	Sinusoidal
<input type="checkbox"/>	Sinusoidal	10.000 UI	10.00 kHz	Clock Modulated

To become active, jitter sources must be switched on (by enabling the corresponding checkbox) and must at least have an **Amplitude** greater than zero.

The **Overview** column consists of buttons that can be pressed to change the parameters of each jitter type independently from others.

Overview
Random
External
Bounded Uncorrelated
Periodic
Sinusoidal

The **Overview** button can be used to return after changing parameters.

Random Jitter Parameters

Amplitude The random jitter **Amplitude** must be entered as an rms (root mean square) value. The rms value corresponds to the sigma factor σ of the bell-shaped Gauss distribution curve (see also [“The Gaussian Marker” on page 169](#)).

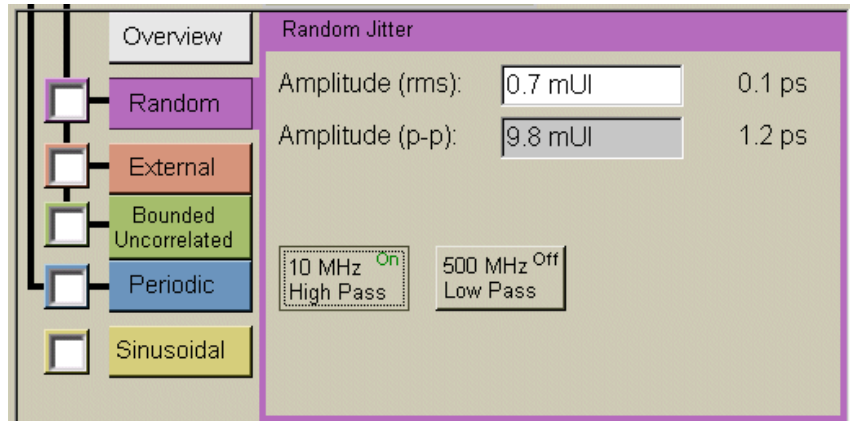

To modify the value, click inside the text field and enter the desired value directly with the numeric keyboard, or use the knob close to the numeric keyboard to fine-tune the value.

Amplitude p-p The peak-to-peak amplitude is calculated by multiplying the rms value with the crest factor (which is currently fixed to 14). The

Amplitude p-p box shows how much of delay line capacity the setting consumes.

Filter The random jitter source is equipped with a 10 MHz high pass and a 500 MHz low pass filter to limit the spectral range. Both filters can be disabled or enabled by pressing the respective buttons.



Bounded Uncorrelated Jitter Parameters

Bounded uncorrelated jitter is characterized by

- Data rate
- Amplitude
- PRBS polynomial
- Low pass filter

A graph indicates whether the chosen setting of frequency and amplitude is tolerable.

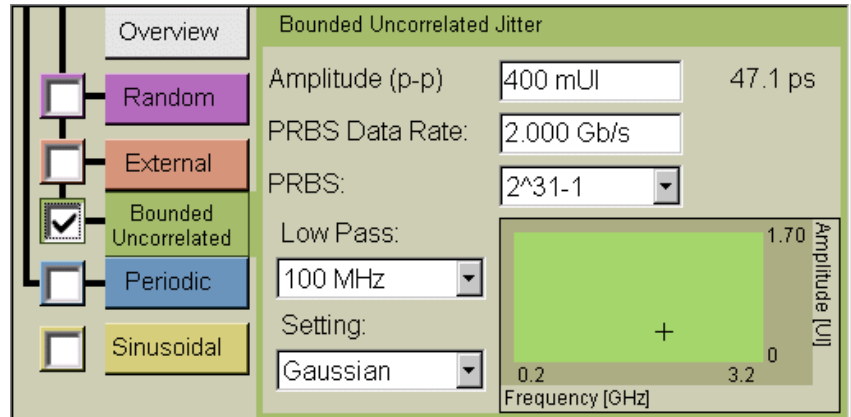

You can specify your own setup or choose one of the predefined settings.

Setting You can choose one of four predefined settings:

- **CUSTOM:** The individual parameter values apply.
- **CEI6G:** Meant for CEI 6 Gbit/s tests: PRBS data rate is 1.1 Gbit/s, the PRBS polynomial is 2^9-1 , the low-pass filter is 100 MHz.
- **CEI11G:** Meant for CEI 11 Gbit/s tests: PRBS data rate is 2 Gbit/s, the PRBS polynomial is $2^{11}-1$, the low-pass filter is 200 MHz.
- **Gaussian:** Preset values for Gaussian distribution: PRBS data rate is 2 Gbit/s, the PRBS polynomial is $2^{31}-1$, the low-pass filter is 100 MHz.

Data rate Enter an appropriate **Data Rate**. Refer to the technical specifications.

Amplitude The maximum peak-to-peak **Amplitude** is limited by the free capacity of the 200+ps delay line.

PRBS The **PRBS** polynomial can be chosen from a list. Available are eight polynomials, from 2^7-1 up to $2^{31}-1$.

Filter The bounded uncorrelated jitter source is equipped with four low-pass filters with cut-off frequencies at 20, 50, 100, and 200 MHz. One of these filters is always active.

Periodic Jitter Parameters

Periodic jitter (PJ) is characterized by

- Amplitude

- Frequency
- Waveform

A graph indicates whether the chosen setting of frequency and amplitude is tolerable.

NOTE

The lighter area marks the overprogramming area. These values can be programmed, but they are not calibrated and specified. It is advised to verify error-free instrument operation before doing the measurement.

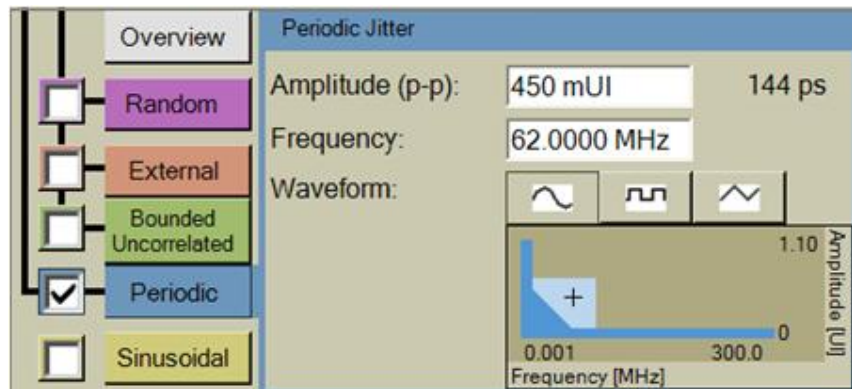

Amplitude The maximum peak-to-peak **Amplitude** is limited by the free capacity of the chosen delay line.

Frequency The maximum **Frequency** of the periodic jitter source depends on the chosen waveform. Refer to the technical specifications.

Waveform You can switch between sine, rectangular, or triangular jitter source waveforms.

External Jitter Source Parameters

When you enable the **External** checkbox, the **Jitter Setup** function reserves the remaining free capacity of the 200⁺ps delay line for the signal applied to the Delay Ctrl Input.

The parameter window informs you about

- Amplitude (max)
- Voltage (max)
- Slope

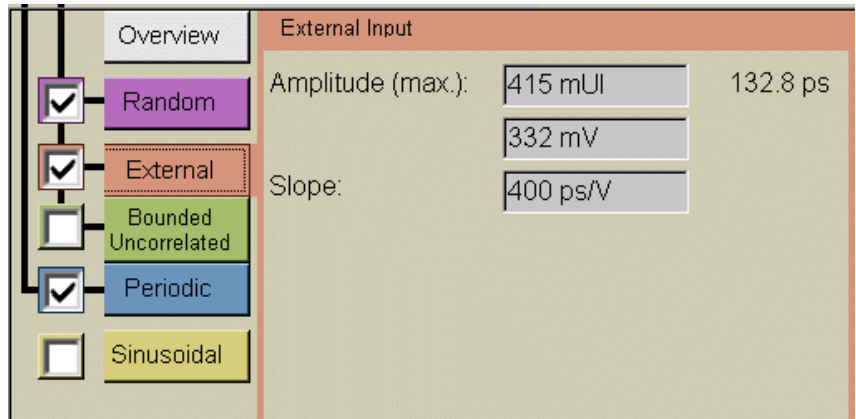

NOTE

Even if the **External** jitter source is enabled, you can still add or change internal jitter components. The range of the external jitter source is automatically updated when you add, change, or turn off one of the internal sources.

Amplitude This is the maximum jitter **Amplitude** that can be generated.

Voltage This is the maximum voltage that can be accepted. It would generate the maximum jitter amplitude. Before connecting an external jitter signal, always ensure that this signal does not exceed the maximum voltage.

NOTE

The Delay Control Input has an overvoltage protection. For details see [“Delay Control Input - Concepts”](#) on page 97.

Slope The **Slope** indicates the present relation between the voltage applied and the resulting delay.

Sinusoidal Jitter Parameters

Sinusoidal jitter is independent from periodic jitter. It is generated by modulating the clock that is used for data generation. It can therefore not be enabled, if SSC is active.

Sinusoidal jitter is characterized by

- Amplitude (peak-to-peak)
- Frequency

There is a dependency between frequency and acceptable amplitude. A graph indicates whether the chosen setting of frequency and amplitude is acceptable.

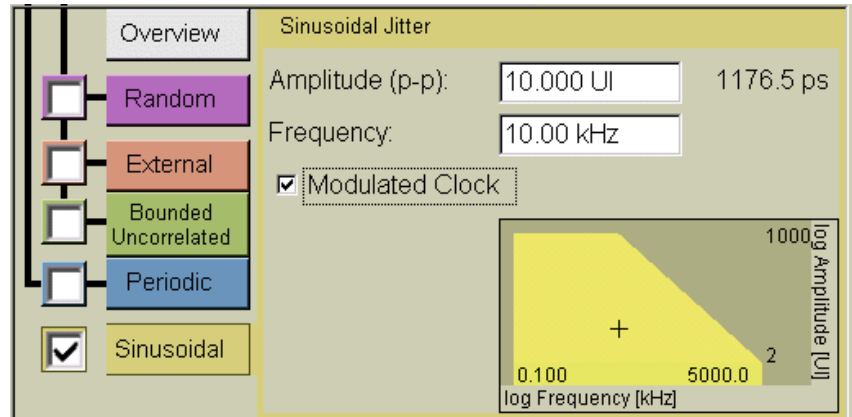

Amplitude The maximum peak-to-peak **Amplitude** is limited by the chosen jitter frequency.

Frequency Note that *high-frequency* sinusoidal data jitter can be generated by the **Periodic Jitter** function or by applying an **External** jitter source.

Modulated Clock This checkbox controls a switch. The Clock Output and Trigger Output ports can be connected before or after the clock modulator (the Substrate Clock Output always follows the clock modulator).

When this checkbox is enabled, the Clock Output provides and the Trigger Output follows the modulated clock. When this checkbox is disabled, the Clock Output and the Trigger Output ports provide pure signals without sinusoidal jitter.

NOTE

This checkbox has no effect when spread spectrum clocking is active. SSC takes effect on all clock and trigger outputs.

Interference Channel Setup

Interference Channel Setup - Concepts

The optional Interference Channel module can be plugged into the instrument. For an introduction please refer to [“Interference Channel” on page 323](#).

This module is to be connected between the pattern generator's Data Out port and the DUT. For installation instructions refer to [“Installing Hardware Options - Procedures” on page 406](#).

The Interference Channel simulates intersymbol interference (ISI). It has backplane traces that conform to the Nelco 4000-6 FR4 specification.

The trace length can be set. According to the chosen length, the module generates a reproducible amount of intersymbol interference.

The Interference Channel provides also a sinewave generator and a modulator. If sinusoidal interference (amplitude modulation) is enabled, a minimum trace length is used.

Data can be input at P1 or P2 by connecting the pattern generator's Data Out to P1 or P2, respectively.

The output is meant to be connected to the input of the DUT.

CAUTION

The module has golden 2.4 mm connectors. Be sure to use the specific cables or adapters. Improper connection can damage the module.

Interference Channel Setup - Procedures

To set up the Interference Channel module, click the corresponding icon of the **Jitter** panel.



To use the Interference Channel module:

- 1 Click the checkbox that enables the module.
- 2 Select a trace (refer to the technical specifications for details)
- 3 If desired, enable sinusoidal interference.

If you have enabled sinusoidal interference, enter appropriate values for **Frequency**, **Amplitude**, and **Mode**.

Interference Channel Setup - Reference

The Interference Channel module must be enabled before it can be used. This is done by clicking the corresponding checkbox.

When the Interference Channel is disabled, it establishes an almost direct connection between P1 and P2. For details about the minimum trace length refer to the technical specifications.

Trace Number

To specify the degree of intersymbol interference, select a suitable trace length.

The user interface provides numbers from 1 to 9. The greater the number, the longer is the trace.

Sinusoidal Interference

To enable the addition of sinusoidal interference, press the corresponding checkbox.

Set the parameters to desired values:

Amplitude The peak-to-peak amplitude of sinusoidal interference must not exceed a certain level (see the technical specifications).

Frequency The frequency range of sinusoidal interference is limited (see the technical specifications).

Mode One of four modes can be chosen for sinusoidal interference:

- **Common:** Requires that a differential data signal is generated and connected to P1/ $\overline{P1}$ or P2/ $\overline{P2}$ of the Interference Channel.
In common mode, both components of the differential data signal are amplitude-modulated with the same sinewave. This adds common mode noise.
- **Differential:** Requires that a differential data signal is generated and connected to P1/ $\overline{P1}$ or P2/ $\overline{P2}$ of the Interference Channel.
In differential mode, both components of the differential data signal are amplitude-modulated, one with the normal sinewave, the other with the inverted sinewave. This adds differential noise.
- **Single-ended normal:** Modulates the data signal that is connected to P1 or P2 of the Interference Channel.
- **Single-ended complement:** Modulates the data signal that is connected to $\overline{P1}$ or $\overline{P2}$ of the Interference Channel.

Jitter Tolerance Characterization

Jitter Tolerance Characterization - Concepts

During a jitter tolerance characterization test, jitter is applied sequentially at a number of frequency points in the frequency range of interest.

The receiver checks for the onset of transmission errors and increments/decrements the jitter amplitude using a control algorithm, re-testing for errors at one frequency point until the target BER threshold is found. This is repeated for each subsequent jitter frequency step to provide a plot of the DUT tolerance.

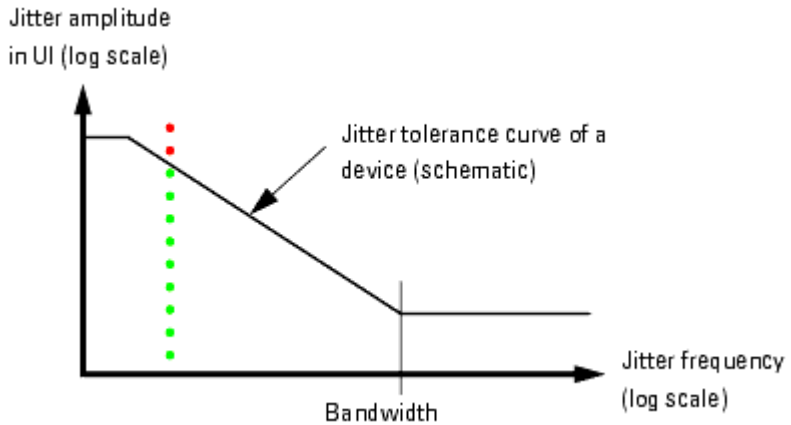

Green points (BER below limit) and red crosses (BER above limit) are used to display the results.

After a measurement has exceeded the target BER or when moving to the next frequency point, a measurement settling or relax time can be applied. This allows the DUT to settle after changes and before the next measurement; this is important because some devices may need time to recover from error conditions caused by jitter exceeding the margin during the search for the threshold.

The maximum jitter amplitude the Serial BERT can generate is also frequency dependent, as illustrated below.

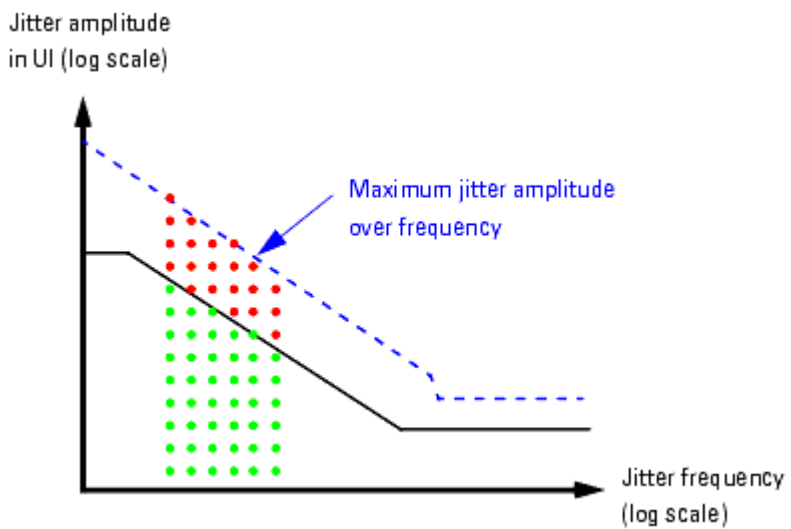

Sinusoidal jitter (SJ) and periodic jitter (PJ) with sinusoidal characteristic are used for the test. Whether SJ or PJ is used depends on the jitter frequency. SJ supports wide amplitude variations up to some MHz. PJ supports narrow amplitude variations over a wide frequency range. The measurement switches automatically between the two sources.

When the measurement has finished, the jitter composition shown in the **Jitter Setup** window is restored.

Target BER

The target bit error ratio must be specified.

The condition for moving from one jitter amplitude step to the next can be set to

- numbers of received bits and errors
- a confidence level

Additionally, a relax time can be specified.

Number of received bits or errors

When numbers of received bits or errors are enabled, the measurement proceeds with the next amplitude as soon as one of the two numbers is reached.

But we are often dealing with very small tolerable bit error ratios, 10^{-12} and below. Measuring such a bit error ratio precisely (and just for one single point) takes time.

Confidence level

The Jitter Tolerance Characterization measurement offers therefore the option to set a level of confidence. This approach is based on statistics.

Statistics tell us, for example, that if we receive 3×10^{12} bits without any error, the probability that the BER is below 10^{-12} is higher than 95 %. If an error occurred, more bits must be compared to achieve the same confidence level. For details see [“Explanation of the Fast Total Jitter Measurement” on page 178](#).

The measurement proceeds with the next amplitude as soon as the desired level of confidence is reached. Setting a confidence level ensures that neither too few nor too many bits are captured.

Relax time

If the measured BER is higher than the target bit error ratio, the device under test may have lost synchronization. For devices that need some time to recover from the situation, a relax time can be specified. This time takes effect each time the BER limit has been exceeded. The next BER measurement starts after this time has elapsed.

Vertical Search Methods

You can specify that the jitter amplitude changes in linear steps from maximum to minimum or vice versa. The step size is adjustable.

You can also specify that the jitter amplitude changes in logarithmic steps from maximum to minimum or vice versa. Minimum and ratio are adjustable.

Alternatively, you can also specify one of two dynamic (binary) search methods.

Searching Down/Up

Both search directions, upwards and downwards, are supported. This helps to find out whether the device exhibits some degree of hysteresis. The BER measured at a specific jitter amplitude may be different if this amplitude is approached downwards or upwards.

Searching downwards When you search in downward direction (from maximum to minimum), the test for one frequency stops as soon as the measured BER falls below the target bit error ratio.

The following figure shows an example of a logarithmic search downwards.

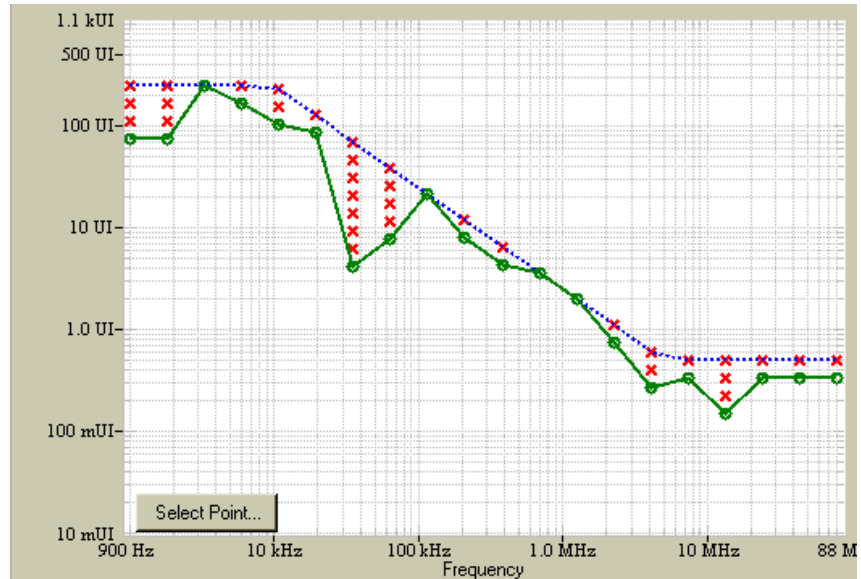

The maximum amplitude (indicated by the dotted blue line) is given by the capability of the instrument.

Searching downwards is usually faster than searching upwards, because the measurement of a single point is finished as soon as the BER is found to be above the limit.

Searching upwards

When you search in upward direction (from minimum to maximum), the test for one frequency stops as soon as the measured BER exceeds the target bit error ratio.

Dynamic Search

If you perform the measurement over a wider frequency range, you measure many useless points with the downwards/upwards methods. To construct the tolerance curve, we actually need only the two points between which the measured result turns from green to red.

To reduce the measurement time without sacrificing precision, the Jitter Tolerance Characterization measurement offers two additional search methods:

Binary search

When binary search is enabled, the measurement starts with the maximum jitter amplitude (100 %).

If the result is red (measured BER higher than target BER), the search goes downwards. The next amplitude is set to 50 %.

If the new result is still red, the next amplitude is set to 25 %. But if the new result is green, the search goes upwards, and the next amplitude is set to 75 %.

Depending on the result, the search algorithm changes the direction and continually halves the step size.

This continues until the specified accuracy (the final step size) is reached.

Binary is the fastest search method. It approaches the amplitude of interest from both sides. However, binary search can lead to incorrect results if the device to be tested shows hysteresis.

Extended binary search This algorithm combines binary with linear downward search.

Extended binary search starts like the binary search. Depending on the result, the search algorithm changes the direction and continually halves the step size.

This continues until the specified coarse step size is reached. Then, the coarse step size is maintained until a transition from green to red is found. After that has happened, the algorithm changes the direction and uses fine linear downward steps of specified size to localize the transition precisely.

Extended binary search takes more time than binary search but leads to reproducible results for devices with hysteresis.

Jitter Tolerance Characterization - Procedures

To access the Jitter Tolerance Characterization measurement, press the corresponding icon of the **Jitter** panel.

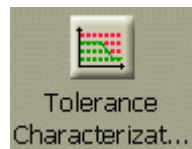

To set up a Jitter Tolerance Characterization test, press the **Properties** button.

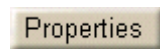

This opens the **Jitter Tolerance Properties** dialog.

Setting the Frequency Range

Choose **Auto** or **Manual** mode.

The screenshot shows the 'Jitter Tolerance Properties' dialog box. It has three tabs: 'Frequency', 'Search', and 'BER'. The 'Auto' radio button is selected. Below it, there are three input fields: 'Start Frequency' with the value '1000 Hz', 'Stop Frequency' with the value '80.000 MHz', and 'Nr. of Steps' with the value '20'. The 'Manual' radio button is unselected. Below it, there is a text box containing the value '1.000000e+003,1.811579e+003;'. At the bottom, there is a 'Show Compliance Curve' checkbox which is unchecked. At the very bottom of the dialog are four buttons: 'OK', 'Cancel', 'Apply', and 'Help'.

In **Auto** mode, the jitter frequencies are automatically calculated:

- 1 Enter the **Start Frequency**.
- 2 Enter the **Stop Frequency**.

Start and stop frequency define the measurement's frequency range.

- 3 Set the **Number of Steps** between start and stop.

The **Number of Steps** yields a set of logarithmically equidistant frequencies.

In **Manual** mode, the automatically calculated jitter frequencies can be edited. You can also enter your own comma-separated list of frequencies.

The **Show Compliance Curve** checkbox enables the compliance curve on the Jitter Tolerance Characterization graph. This feature is available only if the compliance jitter measurement option is installed. The standard is taken from the compliance measurement.

Setting the BER Limit

1 Set the **Target Bit Error Ratio**.

This defines whether a measured point is flagged green or red.

The screenshot shows the 'Jitter Tolerance Properties' dialog box with the 'BER' tab selected. The 'Target Bit Error Ratio' is set to '1e-9'. Under 'Verification Method', 'Confidence Level' is selected with a value of '95.00 %'. 'Absolute Bits/Errors' is also visible with 'Nr. of Bits' set to '1000000000' and 'Nr. of Errors' set to '1000'. The 'Relax Time' checkbox is checked and set to '1.0 s'. Buttons for 'OK', 'Cancel', 'Apply', and 'Help' are at the bottom.

2 Choose the **Verification Method**.

Setting a **Confidence Level** is generally recommended. See also “[Target BER](#)” on page 340.

If you enable **Absolute Bits/Errors**, the measurement proceeds with the next amplitude as soon as one of the two numbers is reached.

3 If desired, set a **Relax Time**.

For details see “[Relax time](#)” on page 341.

Setting the Search Mode

1 Choose one of six search modes:

- Downwards linear
- Downwards logarithmic
- Upwards linear
- Upwards logarithmic

- Binary search
- Extended binary

For details refer to “Vertical Search Methods” on page 341.

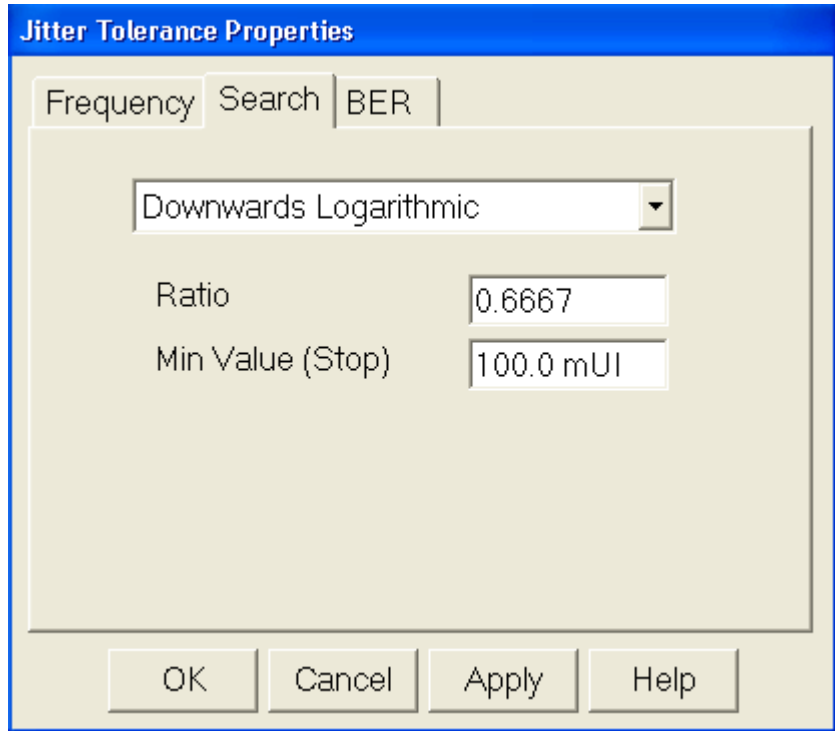

- 2 Accept or change the related parameters.

Before Running the Test

For DUTs that require a training sequence it is essential to prevent clock loss at the beginning or end of the test. To avoid clock loss, the sinusoidal jitter component has to be enabled. Since the sinusoidal jitter for the test is generated internally, the jitter amplitude must be set to zero:

- 1 In the **Jitter** window, press the **Jitter Setup** Icon.

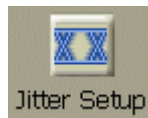

This opens the **Jitter Setup** window.

- 2 Enable jitter generation. Press the respective checkbox.

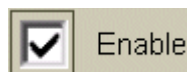

- 3 Activate **Sinusoidal** jitter.

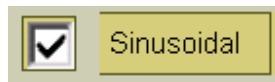

- 4 Activate **Periodic** jitter



- 5 Set the jitter amplitude to 0 UI for both Sinusoidal jitter and Periodic jitter.

If any one of the three above checkboxes is not enabled, then the following screen will appear.

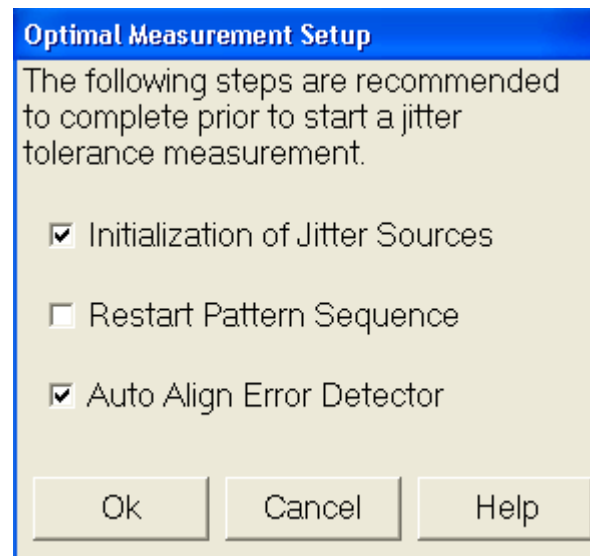

Clicking on 'ok' auto aligns the error detector.

The device can now be tested without clock loss.

NOTE

When SSC is enabled the measurement does not use SJ. The maximum available jitter amplitude is reduced for the jitter tolerance measurement.

Running the Test

Once you have specified the **Frequency**, **BER**, and **Search** criteria, press the **Start** button to run the test.

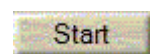

The bar in the lower right-hand corner of the screen shows the progress.

You can also abort the test at any time by pressing the **Abort** button.

Once the measurement has finished, the jitter composition shown in the **Jitter Setup** window is restored.

When the measurement is either completed or aborted, you can obtain a list of measured points by clicking the following tab which appears once the measurement is stopped.

Select Point...

Clicking on the above tab you get the list of measured points.

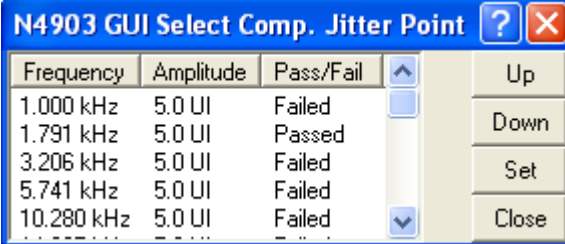

Frequency	Amplitude	Pass/Fail
1.000 kHz	5.0 UI	Failed
1.791 kHz	5.0 UI	Passed
3.206 kHz	5.0 UI	Failed
5.741 kHz	5.0 UI	Failed
10.280 kHz	5.0 UI	Failed

Selecting a point, and clicking on 'Set', updates the Jitter Setup page with the jitter setting of that point.

Generate HTML Report

The measurement results can be saved as HTML file. To generate the HTML report:

- 1 Click the 'Jitter' tab on the toolbar. The following drop down list will appear.

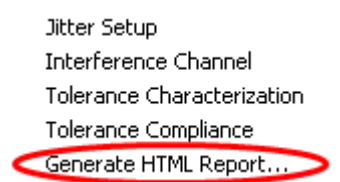

- 2 Select 'Generate HTML report'.
- 3 Select the folder where you want to save the report, name the folder, and save it.

Jitter Tolerance Characterization - Reference

Jitter tolerance characterization determines the actual jitter levels where the device under test can no longer maintain a desired BER.

Frequency Specification

You can choose **Auto** or **Manual** mode.

Auto mode In **Auto** mode, the jitter frequency is automatically swept from **Start Frequency** to **Stop Frequency**.

- **Start Frequency:** This is the minimum and first jitter frequency to be generated. It determines the left-hand border of the graphical result display.
- **Stop Frequency:** This is the maximum and last jitter frequency to be generated. It determines the right-hand border of the graphical result display.

The measurement always includes the start and stop frequencies. The frequency scale is logarithmic.

- **Number of Steps:** The **Number of Steps** between start and stop defines the test frequencies.

To determine the individual test frequencies, an algorithm divides the horizontal logarithmic scale into a set of logarithmically equidistant frequencies.

Manual mode In **Manual** mode, you can edit the automatically calculated frequencies. You can also enter a single frequency or your own list of frequencies. For example, you can jump between low and high jitter frequencies.

Enter the frequencies in Hz, separated by commas, for example:

2e4, 1.75e6, 6.334e5, ...

Show Compliance Curve Enabling this compliance curve helps in ensuring that the device under test complies with a certain standard. This feature is available only if the compliance jitter measurement option is installed. The standard is taken from the compliance measurement.

BER Specification

Target Bit Error Ratio The **Target Bit Error Ratio** defines the required BER. The jitter tolerance curve is constructed from the points where the measured BER crosses the **Target Bit Error Ratio**.

The **Verification Method** defines under which circumstances the measurement proceeds from one jitter amplitude to the next. You can choose between two **Verification Methods**:

Confidence Level Setting a **Confidence Level** is generally recommended. This ensures that neither too few nor too many bits are captured. See also [“Target BER” on page 340](#).

Absolute Bits/Errors If you enable **Absolute Bits/Errors**, the measurement proceeds to the next jitter amplitude as soon as either the number of received bits or the number of errors is reached.

NOTE

Ensure that you capture a number of bits that suffices to verify (with the desired probability) that a measured point has a BER below the **Target Bit Error Ratio**.

Relax Time This is the wait time that takes effect after the measured BER is higher than the target BER. It allows the DUT to recover from the situation. The unit is seconds. The next measurement starts after that time.

Search Specification

On this page of the **Jitter Tolerance Properties** dialog, you specify how the measurement proceeds upwards or downwards from one measured point to the next. The chosen method impacts the measurement duration. The specified parameters influence both measurement duration and precision.

You can choose one of six search methods:

- Downwards linear
- Downwards logarithmic
- Upwards linear
- Upwards logarithmic
- Binary search
- Extended binary

For a description of these methods refer to [“Vertical Search Methods” on page 341](#).

Linear search For linear search, you can set the step size.

- **Downwards linear** starts from the maximum (which depends on the jitter frequency). A step size of 100 mUI, for example, may result in a sequence of 1000 UI, 999.9 UI, 999.8 UI, and so on.

The test for one frequency stops when the BER limit is met or zero amplitude is reached.

- **Upwards linear** starts from the minimum. A step size of 100 mUI, for example, will result in a sequence of 0.1 UI, 0.2 UI, 0.3 UI, and so on. The test for one frequency stops when the BER limit is exceeded or the maximum amplitude is reached.

Logarithmic search For logarithmic search, you can set the minimum amplitude and the ratio. The ratio is the factor by which the present amplitude value is multiplied to calculate the next amplitude.

- **Downwards logarithmic** starts from the maximum (which depends on the jitter frequency). A ratio of 0.666, for example, may result in a sequence of 1000 UI, 666 UI, 444 UI, and so on.

The test for one frequency stops when the BER limit is met or the specified minimum amplitude is reached.

- **Upwards logarithmic** starts from the specified minimum amplitude. A ratio of 1.5, for example, may result in a sequence of 0.1 UI, 0.15 UI, 0.225 UI, 0.3375 UI, and so on.

The test for one frequency stops when the BER limit is crossed or the maximum amplitude (which depends on the jitter frequency) is reached.

Binary search For binary search, you can set the accuracy.

This defines the minimum jitter amplitude step size. The test for one frequency stops when this step size is reached.

For a description of this method refer to [“Binary search” on page 342](#).

Extended binary search For extended binary search, you can set the coarse and fine accuracy. The test for one frequency stops when the BER limit is crossed with fine accuracy amplitude steps.

For a description of this method refer to [“Extended binary search” on page 343](#).

Optimal Measurement Setup For details see [“Optimal Measurement Setup” on page 371](#)

Select Point For details see [“Select Point” on page 371](#)

HTML Report For details see [“HTML Report” on page 371](#)

Jitter Tolerance Compliance

Jitter Tolerance Compliance - Concepts

The Jitter Tolerance Compliance test is used to ensure that the jitter tolerance of the device under test complies with a certain standard.

NOTE

The Jitter Tolerance Compliance measurement is a software option that requires a license. For details on how to obtain and install such licenses refer to [“Obtaining a License” on page 404](#).

Measurement Principle

The Optical Internetworking Forum (OIF) and other institutions have proposed and published standards for testing the performance of data receivers and receiver circuits in the presence of jitter.

These standards prescribe the required jitter tolerance over jitter frequency. The jitter tolerance for each frequency bin is defined by a jitter amplitude (normalized to the bit rate and hence specified in Unit Intervals – UI) and a BER threshold which must not be exceeded.

Jitter Tolerance Curves A simple example is shown in the figure below:

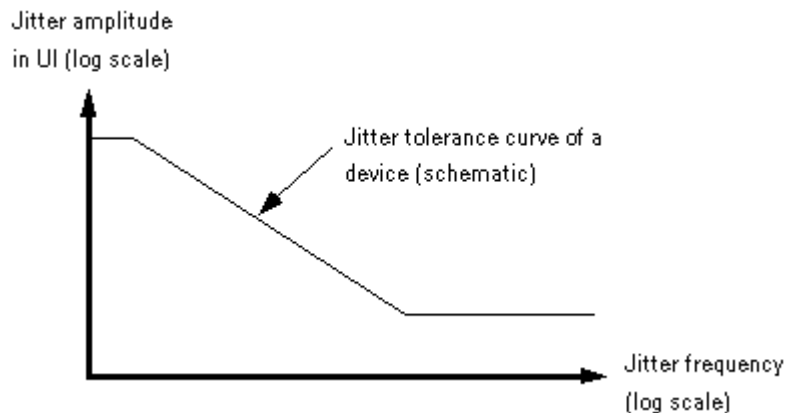

Some standards are more detailed, as illustrated in the following figure:

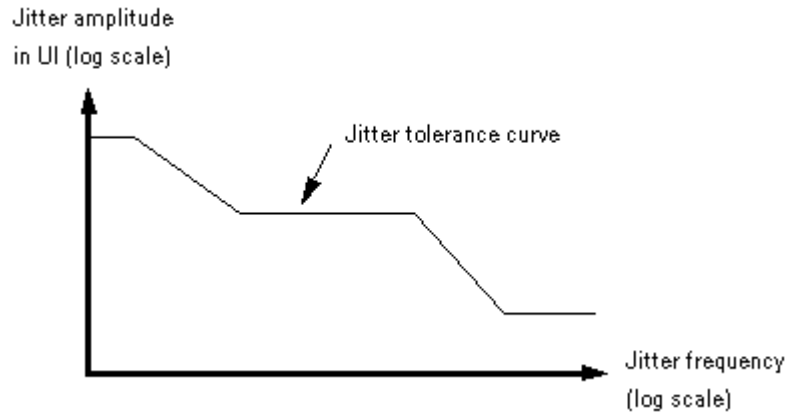

During a jitter tolerance compliance test, jitter with the specified jitter amplitude is sequentially applied at a number of frequency points in the frequency range of interest.

The receiver checks for transmission errors and measures the bit error rate.

Measurement Results The graphical display shows the results.

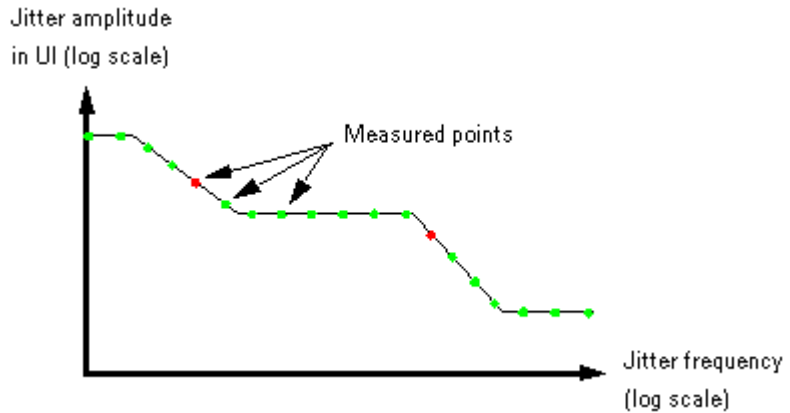

A green circle indicates that the BER at this point did not exceed the target BER. A red cross indicates that the BER at this point exceeded the target BER. If this happens, the test is marked as “failed”.

A table below the graph provides details about the measurement conditions like date/time, data pattern, bit rate, and added jitter components.

The measurement results for each point can also be exported as a numerical list in text format.

Instrument Capability The maximum jitter amplitude the Serial BERT can generate is also frequency dependent, as illustrated below.

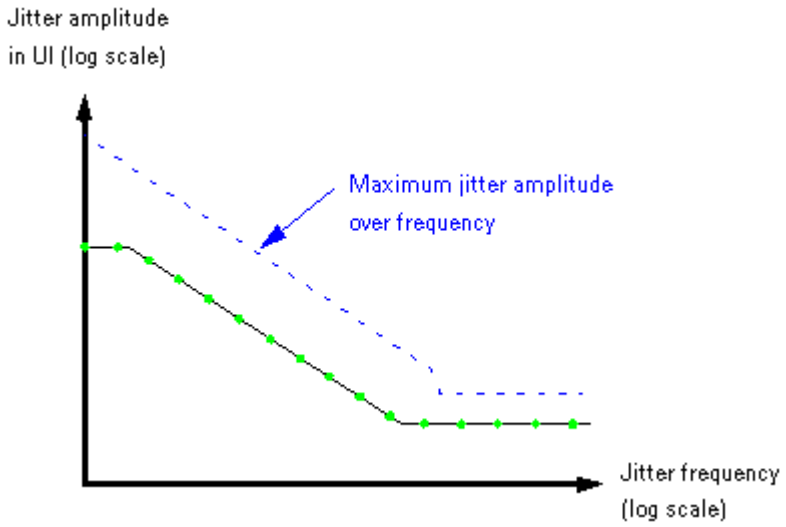

Jitter Type The standards demand and the measurement generates jitter with sinusoidal distribution.

In terms of the Serial BERT, sinusoidal jitter (SJ) and periodic jitter (PJ) with sinusoidal characteristic are used for the test (see also “[How the N4903 Generates Jitter](#)” on page 321).

Whether SJ or PJ is used depends on the jitter frequency. SJ supports wide amplitude variations up to some MHz. PJ supports narrow amplitude variations over a wide frequency range. The measurement switches automatically between the two sources.

The measurement cannot be executed if jitter generation is totally disabled. SJ and PJ may be enabled or disabled.

NOTE

SJ and SSC (Spread Spectrum Clock, option J11) operate mutually exclusive. If you run a Jitter Tolerance Measurement while SSC is active, only PJ, together with 200 +ps delay line, will be used to perform the measurement.

If desired, you can add additional jitter of random, external, or bounded uncorrelated origin to the automatically generated jitter.

When the measurement has finished, the jitter composition shown in the **Jitter Setup** window is restored.

Target BER

The target bit error ratio must be specified.

The condition for moving from one jitter amplitude step to the next can be set to

- numbers of received bits and errors
- a confidence level

Additionally, a relax time can be specified.

Number of Received Bits or Errors

When numbers of received bits or errors are enabled, the measurement proceeds with the next frequency as soon as one of the two numbers is reached.

But we are often dealing with very small tolerable bit error ratios, 10^{-12} and below. Measuring such a bit error ratio precisely (and just for one single point) takes time. Therefore, the measurement provides the option to set a confidence level.

Confidence Level

The Jitter Tolerance Compliance measurement offers the option to set a level of confidence. This approach is based on statistics.

Statistics tell us, for example, that if we receive 3×10^{12} bits without any error, the probability that the BER is below 10^{-12} is higher than 95 %. If an error occurred, more bits must be compared to achieve the same confidence level. For details see [“Explanation of the Fast Total Jitter Measurement” on page 178](#).

The measurement proceeds with the next frequency and jitter amplitude as soon as the desired level of confidence is reached. Setting a confidence level ensures that neither too few nor too many bits are captured.

Relax Time

Before the measurement proceeds to the next frequency bin, a measurement settling or relax time can be applied.

This allows the DUT to recover in case it has lost synchronization due to an excessive high bit error rate. The next BER measurement starts after this time has elapsed.

About Jitter Tolerance Standards

Every Jitter Tolerance Compliance test requires a standard. You can use one of the predefined standards. Additionally, you can define and use your own "user-defined" standard.

In terms of the Serial BERT, a standard is represented by a sequence of paired numbers. Each pair consists of a frequency value (Hz) and the associated jitter amplitude value (UI).

Also part of a standard specification are the standard's name and descriptive text.

Predefined Standards

The Jitter Tolerance Compliance option provides a number of predefined standards.

Standard Specifications

Predefined standards specify:

- Jitter frequency range

The jitter frequency range may depend on the bandwidth of the receiver being tested.

- Bit rate range

Some standards define the jitter tolerance curve as a function of the bit rate. If this is the case, the edges of the jitter tolerance curve are shifted towards higher frequencies if the bit rate is increased, and vice versa.

- Jitter amplitudes in defined sections of the jitter frequency range

The slopes between adjacent sections may be double logarithmic (shown as straight lines in the double logarithmic display) or are calculated according to certain algorithms.

- Data pattern to be used

This can be, for example, a certain PRBS-polynomial or a specific test pattern.

- Signal voltage range

Most standards refer to specific devices.

- Jitter composition

A standard may prescribe that additional jitter components with specific amplitudes have to be added.

Using Standards

The standards provided by Agilent can be chosen from a list of predefined standards.

Every standard is accompanied by a description that states its specific requirements, like applicable bit rates, patterns to be used, and so on.

NOTE

Before running the test, set up the instrument to ensure that these requirements are met. For details on the recommendations and their dependencies see **Description** in the “Standard Specification” on page 368.

If a standard specifies a tolerance curve that is bit rate dependent, the curve is automatically adapted to the present bit rate. If you change the bit rate, the curve is automatically recalculated.

The standards provided by Agilent cannot be edited locally.

User-Defined Standards

You can create your own standard in a text file.

User-Defined Standard Specifications

A user-defined standard consists of a paired list of numbers.

Each pair specifies a jitter frequency (Hz) and the associated jitter amplitude (UI), for example:

```
2e3, 110<cr><lf>
3.24e4, 50<cr><lf>
71.234e4, 10<cr><lf>
10.654e6, 0.2<cr><lf>
18.333e6, 0.2<cr><lf>
```

<cr><lf> stands for <carriage return><line feed> or just <Return>.

NOTE

The list must be sorted according to the frequencies in ascending order. The jitter amplitude for a given frequency must not exceed the instrument’s capability.

The list of predefined standards has a **Browse** option that allows you to identify and load such a text file.

If you have selected a text file, you can append it to the list of predefined standards. You can assign a name to your standard and add a description. Then, your standard appears directly in the list like the standards provided by Agilent, and you don’t have to browse any more.

Your standard is stored in a file with the suffix .jcs. This is still a text file which can be edited. The directory is C:\N4903A\JTolStandards.

Using User-Defined Standards

User-defined standards are taken “as is”. That means, neither the bit rate nor any other conditions are taken into account.

The instrument uses double logarithmic interpolation to generate the jitter amplitudes between two successive amplitude values. This is indicated by linear slopes in the double logarithmic graph.

Special Features

You can freely specify the jitter frequency range and the number of points to be measured. You can also adjust the frequency range and the point positions to the loaded standard.

In addition, you can add a margin to the standard.

Jitter Frequency Test Points

You can specify the jitter frequency range to be used for the test, from 1 kHz up to some hundred MHz. You can hence measure only a portion of the standard or points outside the standard. Points outside the standard will always pass the test.

If a standard prescribes a certain range, for example from 2 kHz to 20 MHz, you can select a checkbox to adjust the jitter frequency range to the loaded standard.

You can also specify the number of points to be measured. By default, the measurement points are evenly distributed along the logarithmical frequency axis.

You may wish to measure the BER exactly at those frequency points where the specified jitter amplitude changes. By selecting a checkbox, the distribution of the measurement points can be adapted to the loaded standard, and the BER at the points of interest will be measured.

Margin

It is possible to increase the jitter amplitudes of any standard by adding a margin. This increases the stress on the device under test.

The margin is set in percent. A margin of 25%, for example, has the effect that each amplitude value is multiplied by 1.25.

The following figure shows an example of a measurement with a margin of 50% and sample point adaptation.

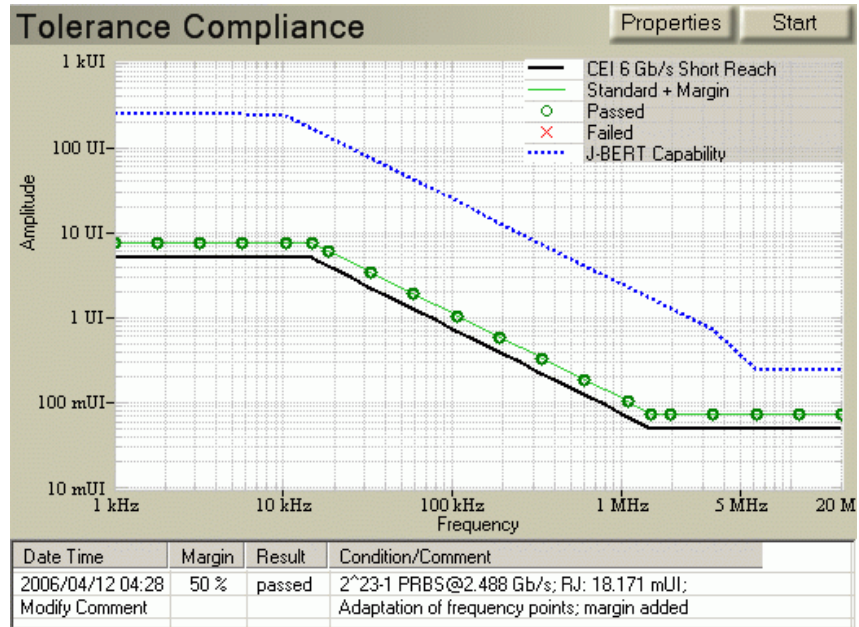

Jitter Tolerance Compliance - Procedures

To access the Jitter Tolerance Compliance measurement, press the corresponding icon of the **Jitter** panel.



To set up a Jitter Tolerance Compliance test, press the **Properties** button.

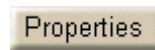

This opens the **Jitter Tolerance Properties** dialog.

Setting the Standard

Select either a predefined standard or load a standard from a text file.

- 1 Switch to the **Standard** tab.

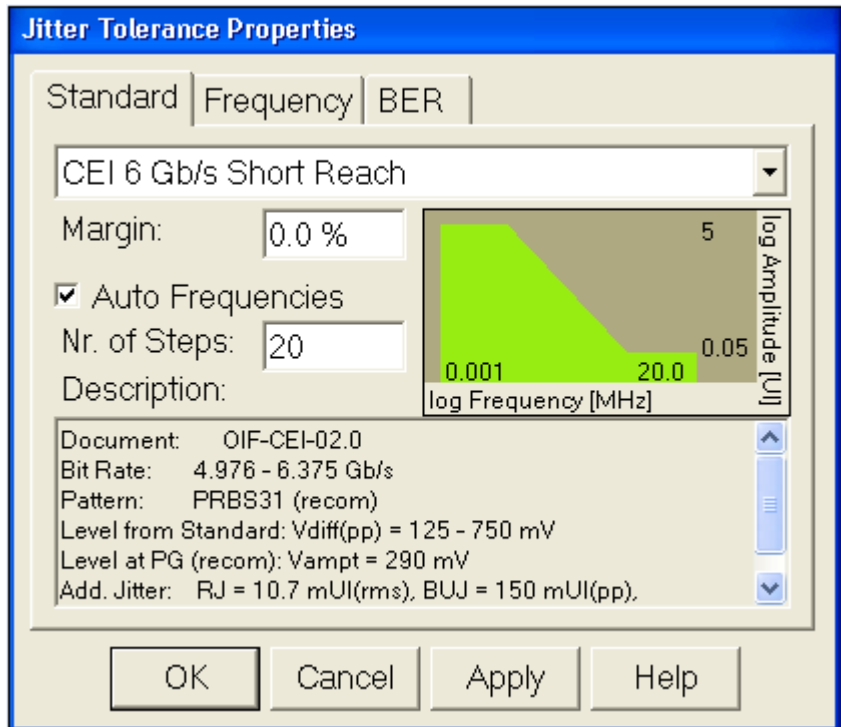

A preview and a short description of the selected standard are displayed.

- 2 To load a different standard, open the list.

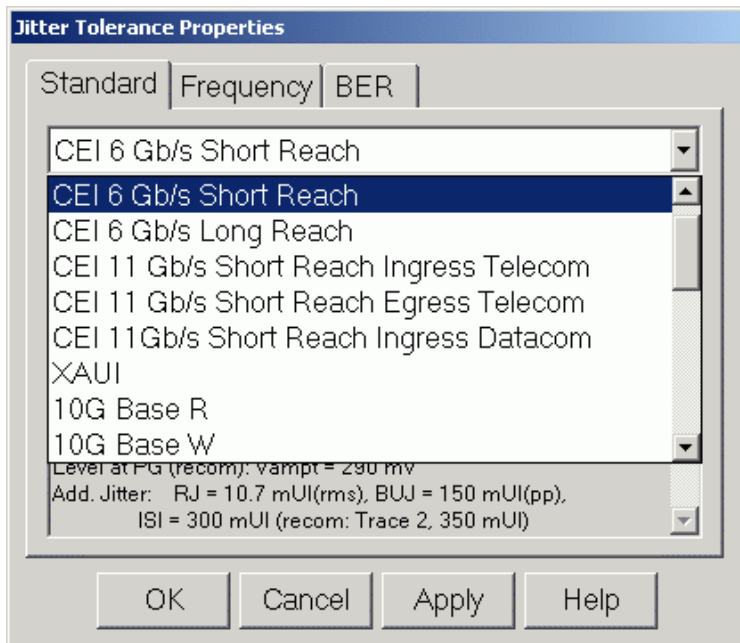

The list contains all predefined standards, including user-defined standards. User-defined standards are preceded by an asterisk (*).

- 3 Select one of the predefined standards.

or

Press **Browse...** to load your own standard, stored in a text file.

This opens a dialog box which allows you to load a file. By default, the browser searches for files with the suffix .jcs, but you can access any file.

NOTE

The required file format is described in detail in [“User-Defined Standards” on page 357](#).

- 4 Press **OK** to load the data temporarily. Use this option, for example, if the jitter-frequency list of your standard is still subject to change.

or

Press **Apply to Predefined Standards** to load the data and add the standard to the list of predefined standards. For details see [“Adding a User-Defined Standard” on page 366](#).

If you wish to increase the stress on the device under test, you can enter a **Margin**.

TIP

With the **Auto Frequencies** checkbox, you can adjust the test frequencies automatically to the selected standard. This is described below in [“Setting the Frequency Range” on page 361](#).

Setting the Frequency Range

You can freely specify the jitter frequency range and the number of points to be measured. By default, the test points are suitably distributed within the frequency range – according to the loaded standard. But you can change the distribution according to your needs.

- 1 Switch to the **Frequency** tab.

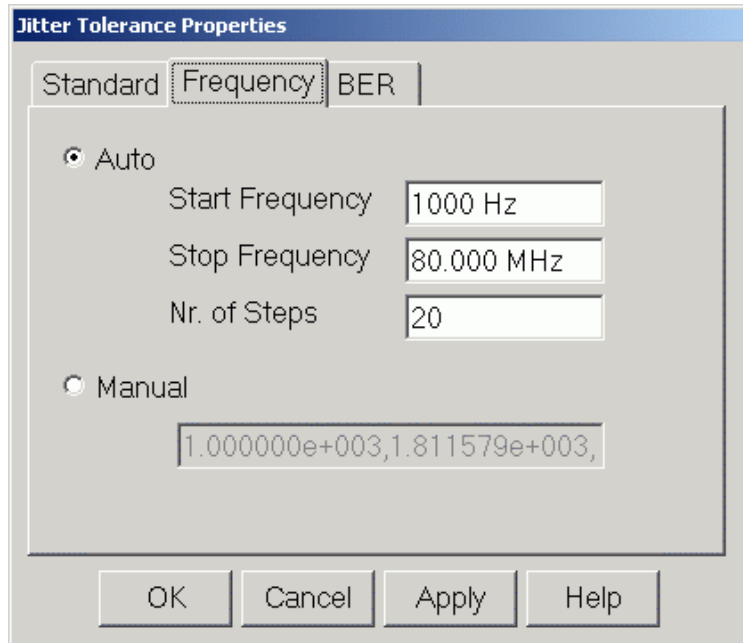

The measurement's frequency range and the list of test frequencies are displayed.

If the **Auto Frequencies** checkbox on the **Standard** tab is selected, start and stop frequency are by default set according to the selected standard.

NOTE

When you change the selection state of the **Auto Frequencies** checkbox, press **Apply** on the **Standard** tab to accept the change and to update the frequency list.

2 If desired, change the default values. For example, if only a certain frequency range has to be tested:

Enter the **Start Frequency** and the **Stop Frequency**.

3 Set the **Number of Steps** between start and stop.

TIP

When **Auto Frequencies** is activated, the **Number of Steps** can also be set on the **Standard** tab.

The resulting frequency list depends on the setting of the **Auto Frequencies** checkbox on the **Standard** tab:



- Checkbox is selected (default):

The list yields frequencies that are recommended for the selected standard, for example the edge frequencies.

- Checkbox is not selected:

The list of frequencies yields a set of logarithmically equidistant frequencies.

In **Manual** mode, the automatically calculated jitter frequencies can be edited. You can also enter your own comma-separated list of frequencies.

NOTE

If the frequency list is edited in **Manual** mode, the **Auto Frequencies** checkbox on the **Standard** tab is automatically deselected.

Setting the BER Limit

- 1 Set the **Target Bit Error Ratio**.

This defines whether a measured point is flagged green (test passed) or red (test failed).

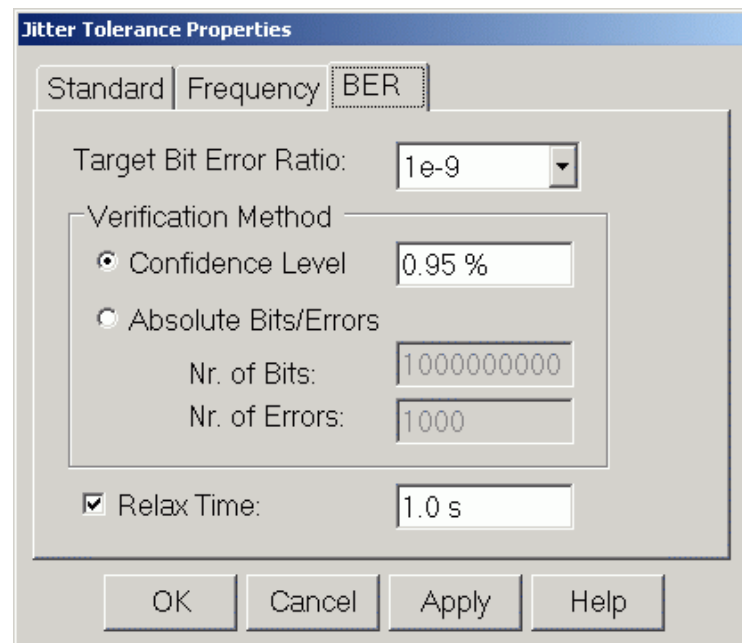

- 2 Choose the **Verification Method**.

Setting a **Confidence Level** is generally recommended. See also “[Target BER](#)” on page 354.

If you enable **Absolute Bits/Errors**, the measurement proceeds with the next amplitude as soon as one of the two numbers is reached.

- 3 If desired, set a **Relax Time**.

For details see “Relax Time” on page 355.

Before Running the Test

Before running the test, set up the instrument to ensure that the requirements of the selected standard are met. Recommended test pattern and additional jitter are displayed in the standard's description field on the **Standard** tab of the **Jitter Tolerance Properties** dialog.

For details on the recommendations and their dependencies see **Description** in the “Standard Specification” on page 368.

Avoiding Clock Loss

For DUTs that require a training sequence it is essential to prevent clock loss at the beginning or end of the test. To avoid clock loss, the sinusoidal jitter component has to be enabled. Since the sinusoidal jitter for the test is generated internally, the jitter amplitude must be set to zero:

- 1 In the **Jitter** window, press the **Jitter Setup** Icon.



This opens the **Jitter Setup** window.

- 2 Enable jitter generation. Press the respective checkbox.

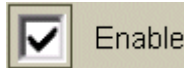

- 3 Activate **Sinusoidal** jitter.

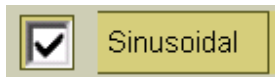

- 4 Activate **Periodic** jitter



- 5 Set the jitter amplitude to 0 UI for both Sinusoidal jitter and Periodic jitter.

If any one of the three above checkboxes is not enabled, then the following screen will appear.

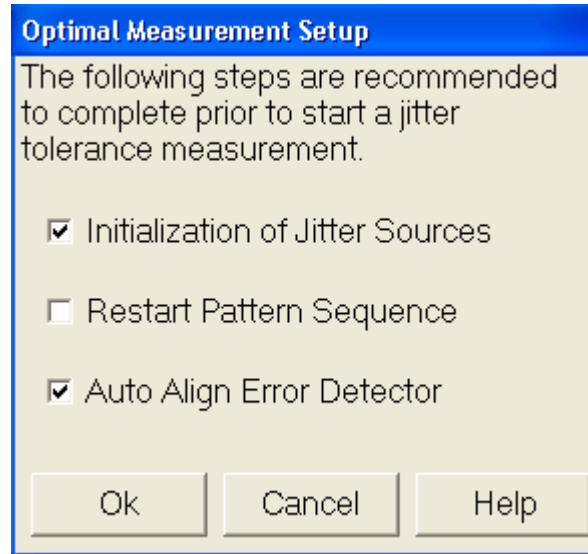

Clicking on 'ok' auto aligns the error detector.

The device can now be tested without clock loss.

NOTE

When SSC is enabled the measurement does not use SJ. The maximum available jitter amplitude is reduced for the jitter tolerance measurement.

Running the Test

Once you have specified the **Standard**, **Frequency**, and **BER**, press the **Start** button to run the test.

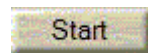

The bar in the lower right-hand corner of the screen shows the progress.

You can also abort the test at any time by pressing the **Abort** button.

When the measurement is either completed or aborted, you can obtain a list of measured points by clicking the following tab which appears once the measurement is stopped.



Clicking on the above tab you get the list of measured points.

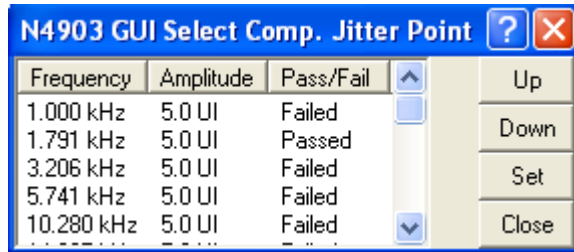

Selecting a point, and clicking on 'Set', updates the Sinusoidal and Periodic jitter of that point on the Jitter Setup page.

Generate HTML Report

The measurement results can be saved as HTML file. To generate the HTML report:

- 1 Click the 'Jitter' tab on the toolbar. The following drop down list will appear.

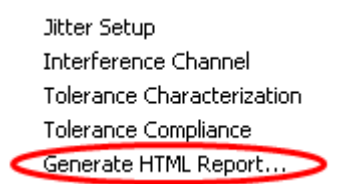

- 2 Select 'Generate HTML report'.
- 3 Select the folder where you want to save the report, name the folder, and save it.

Managing User-Defined Standards

User-defined standards are saved in the folder C:\N4903A \JTolStandards. The extension is .jcs.

Adding a User-Defined Standard

To add a user-defined standard to the list:

- 1 Press the **Properties** button and switch to the **Standard** tab.
- 2 Select the last entry in the list: **Browse...**

This opens a dialog box which allows you to load a file.

NOTE

The file must contain a comma-separated list of frequencies and jitter values. The file format is described in detail in ["User-Defined Standards" on page 357](#).

- 3 Select the desired file and press **Open**.

The **Properties of Imported Standard** dialog is displayed.

- 4 Enter a **Name** and **Description** for the standard.
- 5 Press **Apply to Predefined Standards**.

The standard is added to the list of predefined standards. In the list, user-defined standards are preceded by a "*".

Deleting a User-Defined Standard

To delete a user-defined standard from the list:

- Delete the corresponding file in the C:\N4903A\JTolStandards directory.

Managing Measurement Results

If you want to store the measurement results for later use, you can either save them as an .jcp file (to be opened in the user interface) or as a .txt file for spreadsheet applications.

Saving Measurements

To save a measurement as an .jcp file for later use in the user interface:

- 1 After your measurement has finished and the results are displayed, select **Save Measurement** from the **File > Save** menu.
- 2 Select a proper file name and location and press the **Save** button.

Exporting Measurement Results

To export the measurement results into a .txt file for later use in external spreadsheet applications:

- 1 After your measurement has finished and the results are displayed, select **Export Data** from the **Analysis** menu.
- 2 In the **Save as** dialog box, select the path and file name for the .txt file.
- 3 Press **Save** to export the data to the specified destination.

Loading Measurements

To load previously saved measurements:

- 1 Select **Open Measurement** from the **File > Open** menu.

- 2 Use the file dialog box to locate the desired .jcp file and press **Open** to load the measurement.

Accessing Comment and Condition Text

To access the comment or condition text of a measurement:

- Double-click **Modify Comment** below the graphical display.

This opens the **Jitter Measurement Comment** dialog box.

You can enter a comment. The condition is automatically added by the system.

You can also read the full comment or condition in case only part of the text is displayed in the result table.

Jitter Tolerance Compliance - Reference

Jitter Tolerance Compliance determines whether a device under test maintains a desired BER at defined jitter levels. The jitter levels can be derived from predefined standards.

Standard Specification

Standard Selection The drop-down list contains all predefined standards, including user-defined standards. The shape of the selected standard is shown in the preview area. The frequency range and the jitter amplitude range of the standard is given in the preview. A description is displayed at the bottom of the **Standard** tab.

The last entry in the list is **Browse...** Select this entry to load a file that contains a user-defined standard. See [“Setting the Standard” on page 359](#) for details.

Margin To aggravate test conditions, the standard's test jitter amplitude can be increased by **Margin** percent. The display shows a black line for the standard and a green line for the new jitter amplitudes.

Auto Frequencies / Number of Steps Select the **Auto Frequencies** checkbox to set frequencies that are recommended for the selected standard. This list contains, for example, the edge frequencies of the standard.

TIP

You can change single frequency points. Press **Apply** to accept the selected **Auto Frequencies** setting and switch to the **Frequency** tab. In **Manual** mode, you can edit the automatically calculated frequencies. If you do so, the **Auto Frequencies** checkbox is automatically deselected.

Enter the number of test frequencies (**Number of Steps**) either on this tab, or on the **Frequency** tab.

Description

This is the creator's description of the selected standard. Standards provided by Agilent are described by the following items:

TIP

Use the scroll bar if not all information is displayed.

- **Document** that describes the standard in detail. The document name usually indicates the date or revision of the standard.
- Recommended settings for the test pattern like **Bit Rate** range, **Pattern** types and voltage level ranges:
 - Voltage **Level from Standard**: This is the peak-to-peak differential input level range for the DUT as given in the standard.
 - Voltage **Level at PG (recom)**: This is the recommended output level at the pattern generator to achieve the *minimum* voltage **Level from Standard**.

NOTE

This recommendation depends on the simulated intersymbol interference (ISI): The minimum voltage **Level from Standard** is only met if the trace to simulate the ISI is selected as in the description item **Additional Jitter**. Other settings of the ISI can change the DUT's input level up to four times.

Consider these recommendations when setting up the pattern generator (see [“Setting up the Pattern Generator - Concepts ” on page 69](#)).

- **Additional Jitter** components you have to add for the compliance test if the standard requires non-sinusoidal jitter components, such as random jitter (RJ) or intersymbol interference (ISI).

NOTE

The recommended ISI setting is only valid, if both pattern and bit rate are set according to the standard's recommendation (see the corresponding description items).

Consider these recommendations when composing the desired total jitter (see “[Jitter Setup - Procedures](#)” on page 326). Note that the sinusoidal jitter is automatically generated and no setup is required.

Frequency Specification

You can choose **Auto** or **Manual** mode.

Auto mode In **Auto** mode, the jitter frequency is automatically swept from **Start Frequency** to **Stop Frequency**.

- **Start Frequency:** This is the minimum and first jitter frequency to be generated. It determines the left-hand border of the graphical result display.
- **Stop Frequency:** This is the maximum and last jitter frequency to be generated. It determines the right-hand border of the graphical result display.

The measurement always includes the start and stop frequencies. The frequency scale is logarithmic.

- **Number of Steps:** The **Number of Steps** between start and stop defines the test frequencies.

The location of the individual test frequencies depends on the setting of the **Auto Frequencies** checkbox on the **Standard** tab:

- Checkbox is selected (default):

The list yields frequencies that are recommended for the selected standard, for example, the edge frequencies.

- Checkbox is not selected:

The list of frequencies yields a set of logarithmically equidistant frequencies.

NOTE

Alternatively, you can set the **Number of Steps** on the **Standard** tab.

Manual mode In **Manual** mode, you can edit the automatically calculated frequencies. You can also enter a single frequency or your own list of frequencies. For example, you can jump between low and high jitter frequencies.

Enter the frequencies in Hz, separated by commas, for example:

2e4, 1.75e6, 6.334e5, ...

TIP

Press **Apply** if you want to keep the setting of frequencies for the current test run, but if you still want to change the standard or BER specification. If all properties are set as desired, press **OK**.

BER Specification

Target Bit Error Ratio The **Target Bit Error Ratio** defines the pass/fail criteria of the jitter tolerance compliance test. For every test point along the standard curve, the test is failed if the measured BER lies above the **Target Bit Error Ratio**.

The **Verification Method** defines under which circumstances the measurement proceeds from one frequency to the next. You can choose between two **Verification Methods**:

Confidence Level Setting a **Confidence Level** is generally recommended. This ensures that neither too few nor too many bits are captured. See also “[Target BER](#)” on page 354.

Absolute Bits/Errors If you enable **Absolute Bits/Errors**, the measurement proceeds to the next jitter frequency as soon as either the number of received bits or the number of errors is reached.

NOTE

Ensure that you capture a number of bits that suffices to verify (with the desired probability) that a measured point has a BER below the **Target Bit Error Ratio**.

Relax Time The relax time allows the DUT to recover in case it has lost synchronization due to an excessive high bit error rate. The next BER measurement starts after this time has elapsed.

Optimal Measurement Setup To run the Jitter measurements you need to make sure that Global Jitter, Sinusoidal Jitter and Periodic Jitter are enabled.

Select Point This displays the list of measured points. The list classifies the points with their frequency, amplitude, and status. The status indicates whether the test passed or failed at that point.

HTML Report This contains the results as follows:

- 1 Test Configuration Details:** gives the User Comments, Device Type, Last Test Date, Model Number, Serial Number and Software Revision number.

- 2 **Conditions:** Pattern, Data Rate, Output Level, ISI Trace Number, Additional Jitter, SSC, Target BER, Confidence Level, Relax Time and Margin
- 3 **Graph:** Jitter Tolerance Graph.
- 4 **Measured Points:** List of points classified with their pass/fail status, frequency, Periodic Jitter/Sinusoidal Jitter and Total Jitter without ISI.
- 5 **Recommended Settings** (only in the Compliance Report): Document, Note, Bit Rate, Pattern, Level from Standard, Level at PG (recommended) and Additional Jitter.

Explanation of the Results

Additionally to the graphical results, the measurement provides some information below the graph. You can also export the results to a .txt file.

Understanding the Results

The following information helps you to interpret and document the test:

- **Result** of the test (passed or failed).
- **Date and Time** when the test was finished.
- **Margin** that was set for the test.
- Further test **Conditions** like the selected test pattern and additional jitter components.
- Double-click **Modify Comment**, to enter a **Comment** for every test.

TIP

If not the whole information is displayed in the **Condition/Comment** column, this is indicated by "...". Double-click **Modify Comment** to see the complete text in a separate window.

Exporting Result Data

If you want to use the measurement results with other applications, you can export the data to a file via **Analysis > Export Data...**

The contents of the resulting file may look as follows:

```
Jitter Tolerance Measurement 4/10/2006 12:12:37 PM
Standard: XAUI
Margin: 0 %
Condition: 2^23-1 PRBS@2.488 Gb/s;
Comment:
Passed Points: (frequency; amplitude; number of bits;
bit error rate; number of errors; result)
```

```

1000; 8.5; 3013355404; 0; 0; passed;
1790.61312892; 8.5; 3015843721; 0; 0; passed;
3206.295377462; 8.5; 3015843721; 0; 0; passed;
5741.234598079; 8.5; 3015843721; 0; 0; passed;
10280.33004753; 8.5; 3015843725; 0; 0; passed;
18408.09395274; 8.5; 3013355401; 0; 0; passed;
22100; 8.5; 3015843721; 0; 0; passed;
32961.77471018; 5.69902566387; 3015843724; 0; 0; passed;
59021.78654856; 3.182723041524; 3015843725; 0; 0; passed;
105685.1858862; 1.777448735363; 3013355405; 0; 0; passed;
189241.2813802; 0.9926481084359; 3013355401; 0; 0; passed;
338857.922973; 0.5543621301573; 3015843723; 0; 0; passed;
606763.4457141; 0.3095934689654; 3015843724; 0; 0; passed;
1086478.592045; 0.1728980224511; 3015843725; 0; 0; passed;
1875000; 0.1; 3013355405; 0; 0; passed;
1945462.831206; 0.1; 3015843721; 0; 0; passed;
3483571.287383; 0.1; 3015843721; 0; 0; passed;
6237728.482718; 0.1; 3015843722; 0; 0; passed;
11169358.5158; 0.1; 3015843771; 0; 0; passed;
20000000; 0.1; 3013355409; 0; 0; passed;
Failed Points: (frequency; amplitude; number of bits;
bit error rate; number of errors; result)
    
```

This file can be imported into spreadsheet applications such as Microsoft Excel, for example. Use the semicolons as delimiters for the rows or columns.

	A	B	C	D	E	F
1	Jitter Tolerance Measurement 4/10/2006 12:12:37 PM					
2	Standard: XAUI					
3	Margin: 0 %					
4	Condition: 2*23-1 PRBS					
5	Comment:					
6	Passed Points: (frequen	amplitude	number of bits	bit error rate	number of errors	result)
7	1,00E+03	8,50	3013355404	0	0	passed
8	1,79E+03	8,50	3015843721	0	0	passed
9	3,21E+03	8,50	3015843721	0	0	passed
10	5,74E+03	8,50	3015843721	0	0	passed

TIP

The comment can be entered with the **Modify Comment** button below the graphical result view.

7 Jitter Tolerance Tests

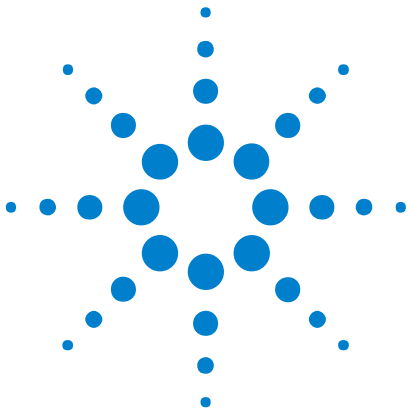

8 Solving Problems

Solving Problems - Concepts

This section provides information that can help you to troubleshoot the Serial BERT in case any problems occur.

Setup Problems

Setup Problems - Concepts

You may run into the following problems when setting up the Serial BERT.

Front Panel not Working

If the front panel is not working and a hardware wizard calls on you to install the driver for an unknown USB device, cancel the hardware wizard and reboot the instrument.

This might happen if the front panel controller is not initialized correctly at boot up.

Incorrect Error Detector Input Voltages

The error detector's protection circuit disconnects the input amplifier if the incoming signal does not lie within the defined input range. In this case, a dialog box will open that lets you define the input range, sample point 0/1 threshold, termination voltage and state. When you click **OK**, the input amplifier will be reenabled.



If the input signal is still out of range for any of these parameters, the error detector will be immediately disconnected again.

Error Detector Does not Count Bits

If the analyzer does not count any bits, press **Sync Now**.

This might happen after bad glitches at the clock input.

DLL Alignment Failed

If an error message containing the text "... **DLL alignment failed** ..." is displayed, increase or decrease the bit rate by 1bit/s.

See "[Bit Rate - Procedures](#)" on page 90 for details on setting the bit rate.

The instrument provides several **error indicators** to help you identify setup problems.



The following list contains possible causes for setup problems, sorted from the most severe to the least severe:

PG CLK LOSS

This indicator turns red when no clock signal is detected at the PG Clock In port.

- **External Clock Input** is selected and the external clock is off or not connected.
- Your cables or the external clock is faulty.

ED CLK LOSS

This indicator turns red when no clock signal is detected at the ED Clock In port.

BERT connected looped back or to your device:

- The PG clock output is off or not connected.
- There is no connection to the ED clock input.
- Your cables are faulty.

BERT connected to your device:

- There is no clock signal from your device.
- Your device is faulty.

DATA LOSS

This indicator turns red when no data signal is detected at the ED Data In port.

BERT connected looped back or to your device:

- The PG data output is off or not connected.
- There is no connection to the ED data input.
- The 0/1 threshold is not in the eye limits of the incoming data signal. Use **Auto Align** or select **Avg 0/1 Threshold**.
- Your cables are faulty.

BERT connected to your device:

- There is no data signal from your device.
- Your device is faulty.

SYNC LOSS

This indicator turns red when the measured BER is higher than the sync threshold.

BERT connected looped back or to your device:

- The sampling point is incorrect. Use **Auto Align**.
- The data pattern is inverted. Toggle **Data Inverted** or use **Auto Align**.
- The ED pattern does not match the incoming data pattern. Make the ED track the PG pattern, or set ED and PG patterns independently the same.
- Patterns have lost sync in manual sync mode. Use **Auto Align, Sync Now**, or select **Auto Sync** mode.

BERT connected to your device:

- The data eye is very small. If **Auto Align** does not correct sync loss, set the 0/1 threshold manually.
- Your device has inverted the data pattern. Toggle **Data Inverted** or use **Auto Align**.
- Your device has changed the data pattern. Set the ED and PG patterns separately.

- If the fundamental BER of your device is higher than the sync threshold BER, you can select a higher sync threshold BER.

Error

This indicator turns red when errors are detected. View the **BER** bar or BER Results to see the nature of the errors.

BERT connected looped back or to your device:

- Stable errors caused by the error add function: Turn error add off.
- Stable errors caused by false sync: Select a lower sync threshold BER.
- Variable and high errors may be caused by faulty connectors/cables.

BERT connected to your device:

- Stable or variable errors can also be caused by your device. Correct the problems with your device.
- If the problems are not clear, then accumulate measurement data and analyze results.

Measurement Problems

Measurement Problems - Concepts

Accumulated measurements can help you determine the cause of bit errors. Bit errors can be caused by a variety of problems. In addition, instrument settings can affect how errors are measured and displayed. The sync mode setting has the greatest effect.

Some phenomenon you might observe with the possible causes are listed below:

Constant Errors (More Errored 0's than 1's)

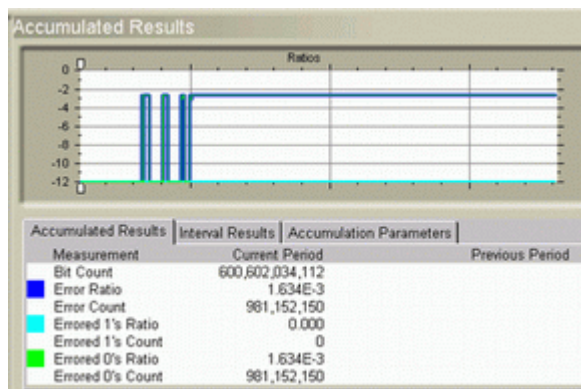

Possible Cause A hardware failure may have occurred in your device. The errors became constant at the point of failure.

Digital circuitry often has parallel architecture in which data lines are multiplexed in stages into one serial data line. This example assumed that a PRBS pattern was going through digital circuitry that had a total multiplexing ratio of 256:1. The constant errors were produced from one data line that became "stuck" high in the first stage of multiplexing.

The data line that was "stuck" high produced errored 0's 50% of the time with the PRBS pattern. Therefore, at the serial rate, one out of every 512 bits was measured as an errored 0 ($1/256 * 50\% = 1/512$). In addition, the inverse of the error ratio was a multiple of 2.

Additional Information In this example, the analyzer could have been in manual sync or auto sync mode with $1E-2$ as the sync threshold BER. If the sync mode settings were different, the results would not have been measured and displayed in the same way.

The BER in this example (approx. $2E-3$) was greater than the default sync threshold BER ($1E-3$). If the analyzer was in the default auto sync mode, it would have activated the synchronization functions and continually shifted the position of the reference pattern in an attempt to find a lower BER.



NOTE

The accumulated results table displays the total accumulated error ratio. Look in the measurement log file to see the error ratio during the period of constant errors.

Example Log of Constant Errors The error ratio during periods of constant errors was 0.00195313. This corresponds to 1.953E-3.

E	F	G	H
ED FREQUENCY	PG FREQUENCY	ERROR COUNT	ERROR RATIO
2.49E+09	2.49E+09	486000	0.00195313
2.49E+09	2.49E+09	486000	0.00195313
2.49E+09	2.49E+09	486000	0.00195313
2.49E+09	2.49E+09	486000	0.00195313
2.49E+09	2.49E+09	486000	0.00195313
2.49E+09	2.49E+09	486000	0.00195313
2.49E+09	2.49E+09	486000	0.00195313
2.49E+09	2.49E+09	486000	0.00195313
2.49E+09	2.49E+09	486000	0.00195313
2.49E+09	2.49E+09	486000	0.00195313

Random Errors

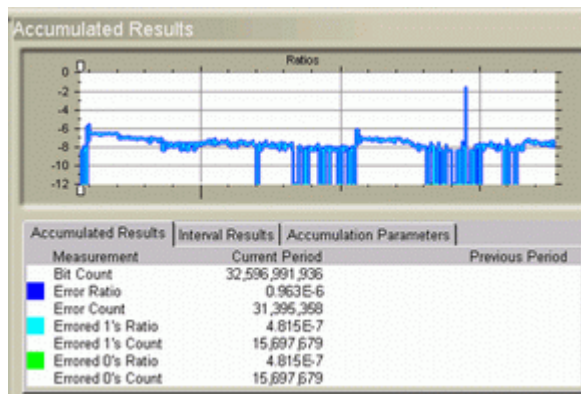

Possible Cause Random errors may have been caused by a noisy waveform. Noise can be caused by bad cables or connectors.

Additional Information The output of your device may contain errors due to noise, although a noisy waveform is not present at the output. The noise may originate somewhere else within your device or system, causing random bit errors to be passed on to other components. Therefore, your device may have a good output waveform and still transmit random bit errors.

Sync Loss Seconds

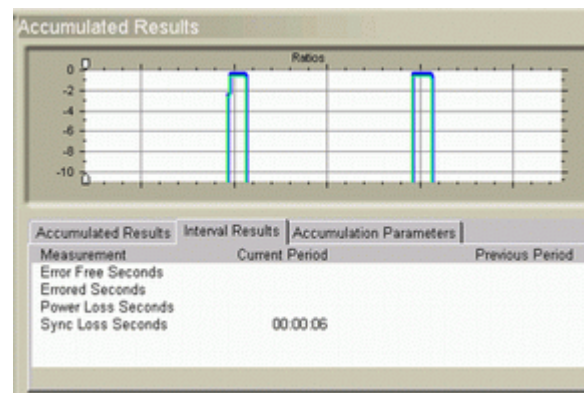

Possible Cause The sync loss seconds in this example may have been caused by high bursts of errors or momentary clock loss. The clock signal from a clock recovery module may have momentarily ceased. To confirm periods of momentary clock loss, check the measurement log file.

Additional Information In this example, the analyzer was in auto sync mode. If the analyzer was in manual sync mode, the results would not have been measured and displayed in the same way.

When the clock signal resumed, the received and ED reference patterns could only be aligned if the synchronization functions were activated. In manual sync mode, this would not have happened because synchronization functions are only activated manually.

In manual sync mode, sync loss and high BER would have been measured from the start of the momentary clock loss to the end of the accumulation period.

Example Log of Sync and Clock Loss Data in this measurement log file confirms that there were periods of momentary clock loss.

M	N	O	P
SYNC LOSS	PG CLOCK LOSS	ED CLOCK LOSS	DATA LOSS

M	N	O	P
1	0	1	0
1	0	1	0
1	0	1	0
1	0	1	0
1	0	1	0
1	0	0	0
1	0	0	0
1	0	0	0
1	0	0	0
1	0	0	0
1	0	0	0
1	0	0	0
1	0	0	0
1	0	0	0
1	0	0	0
0	0	0	0

Using the Measurement Log to Identify Problems

Measurement Logs are saved as CSV (comma separated variable) files. Follow the steps below to view results in a measurement log file:

- 1 Copy the measurement log file from the analyzer to your PC. By default, log files are saved in the folder C:\N4903A\log.
- 2 Open a spreadsheet application on your PC.
- 3 Import the measurement log file. If your application has an import wizard, you may need to indicate that data is delimited with commas.
- 4 Once the file has been imported, you may need to resize columns. The imported log file should appear similar to the following example.

NOTE

During measurement logging, the Serial BERT logs data in ten-second intervals. Your log file may be missing up to the last ten seconds of data. To avoid this condition, accumulate for 10 seconds longer than desired.

	A	B	C	D	E
1	Description: test				
2	Log Time: 05/29/2000 12:14:58.334				
3	Activation Mode: Single				
4	Accumulation Measurement: ELAPSED_SECONDS				
5	Accumulation Limit: 60.000000				
6					
7	Elapsed Time	BIT COUNT	BIT FREQUENCY	ED FREQUEN	
8	0.1	2.49E+08	2.49E+09	2.49E+	
9	0.2	2.49E+08	2.49E+09	2.49E+	
10	0.3	2.49E+08	2.49E+09	2.49E+	
11	0.4	2.49E+08	2.49E+09	2.49E+	
12	0.5	2.49E+08	2.49E+09	2.49E+	

You can view and analyze the following information in the measurement log file:

Table 27

Instantaneous	Cumulative
BIT COUNT	BIT COUNT Cumulative
ERROR COUNT	ERROR COUNT Cumulative
ERROR RATIO	ERROR RATIO Cumulative
ERRORED 0 COUNT	ERRORED 0 COUNT Cumulative
ERRORED 0 RATIO	ERRORED 0 RATIO Cumulative
ERRORED 1 COUNT	ERRORED 1 COUNT Cumulative
ERRORED 1 RATIO	ERRORED 1 RATIO Cumulative
SYNC LOSS	ERROR SECONDS Cumulative
PG CLOCK LOSS	ERROR FREE SECONDS Cumulative
ED CLOCK LOSS	ERROR DECISECONDS Cumulative
DATA LOSS	ERROR FREE DECISECONDS Cumulative
	SYNC LOSS SECONDS Cumulative
	BURST STATUS Cumulative
	BURST SYNC RATIO Cumulative
	TOTAL BURST COUNT Cumulative
	BAD BURST COUNT Cumulative

Other Messages

Other Messages - Concepts

This section covers additional error messages that may occur when working with the Serial BERT.

Overheat Protection

The Serial BERT is equipped with an overheat protection function to prevent it from overheat damage.

Caution Level If the temperature of the error detector or pattern generator exceeds a certain threshold, the Serial BERT displays the following warning message, respectively:



NOTE

The temperature level is not yet critical. However, the Serial BERT may be damaged if operation is continued. The message is intended to inform you to take the appropriate measures. Save your current instrument settings, shut down the Serial BERT and let it cool down before operating it again.

Critical Temperature If the Serial BERT is operated at this state for a longer time, the temperature may reach a critical level. In this case, the following message is displayed:





The Serial BERT will be shut down, your instrument settings will not be saved.

Troubleshooting Overheating

If the Serial BERT has indicated overheating, do the following:

- Shut down the instrument and let it cool (45minutes to 1hour).
- Reduce the environmental temperature.
- Make sure that the fans are running and the ventilation holes are not blocked.
- If the problem continuously recurs, contact Agilent support.

CAUTION

Do not operate the Serial BERT before it has cooled down again. Otherwise your instrument may get damaged.

When you are switching on the Serial BERT after it was shut down due to a temperature error, you will see a message box that informs you about which module caused the problem.

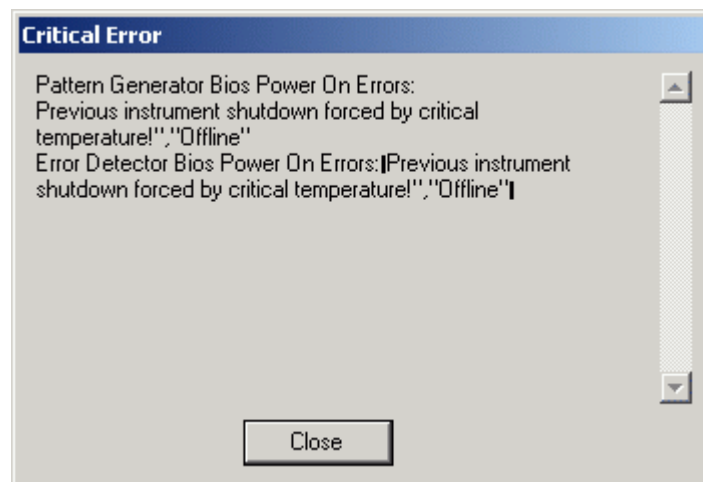

Problems with the N4916A

Problems with the N4916A - Concepts

When you have opened the **PG Output Setup** window and press **De-Emphasis**, the N4916A Connection window appears.

Cannot-Connect Problems

An error message may appear when you now press **Connect**.

If this happens, ensure that the N4916A has been correctly installed (see [“Installing the N4916A - Procedure” on page 407](#)).

Check the Power Supply

Ensure that the power cord is connected.

The green LED close to the power switch must be illuminated when the unit is turned on.

Check the USB Communication

Ensure that the USB cable is connected between the USB port at the rear of the N4916A and one of the USB ports at the rear of the Serial BERT.

- 1 Open the **Utility** menu and click **Minimize GUI** to gain access to the Windows operating system.
- 2 In the Windows task bar, click the Agilent IO Control icon.



- 3 From the **Agilent IO Control** menu, open the **VISA Assistant**.

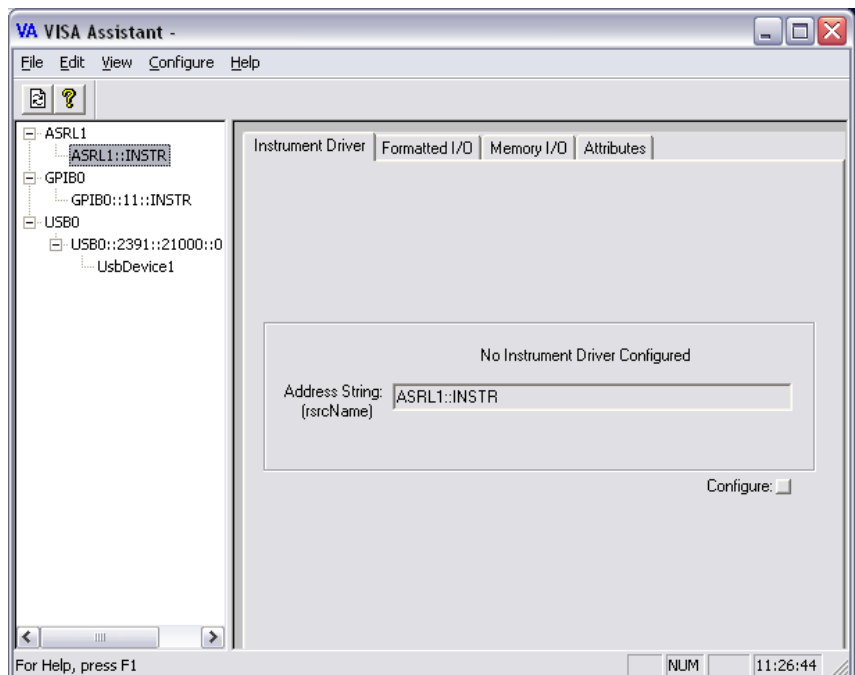

- 4 If no VISA alias name has been assigned so far, the VISA Assistant should indicate an instrument named "UsbDevice1". If the N4916A has been installed correctly, the VISA Assistant should indicate an instrument named "D4916". Click **UsbDevice1** or **D4916**.
- 5 Click the **Formatted I/O** tab.
- 6 In the **Instr. Lang.** box (Instrument Language), enable **SCPI**.

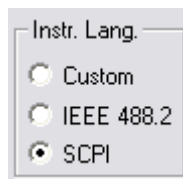

- Click the *IDN? button. This generates the identification query in SCPI format. The instrument should return "Agilent Technologies, N4916A,," and the software revision.

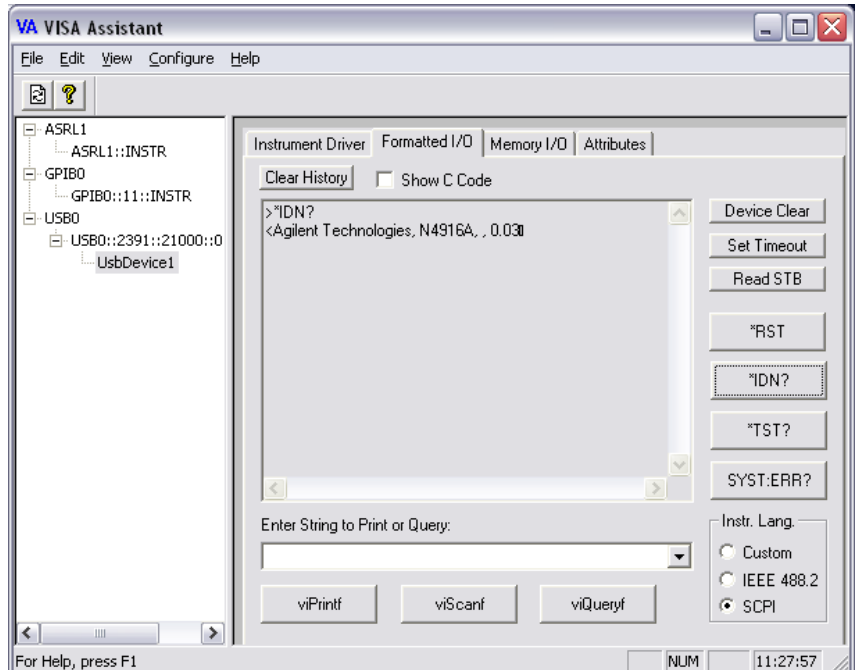

If you could proceed until here, the N4916A power supply and the processor are fully functional. If not, the N4916A is probably defective.

Ensure that the User Software can Access the N4916A

- From the Windows task bar, restore the user interface – click **GUI Agilent 4900 Series**.
- Press the green **Preset** key close to the front USB connector of the Serial BERT or from the menu bar select **File – Preset Instrument State**.
- From the **PG Setup** panel, open the **PG Output Setup** page.
- Press the **De-Emphasis** button.

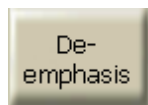

The connection dialog window pops up.

- Connect the Data Out of the Serial BERT to the Input of the N4916A.

- 6 Press **Connect** to activate the connection between the Serial BERT and the N4916A.



You should see the setting of the de-emphasis value and the **Disconnect** button:

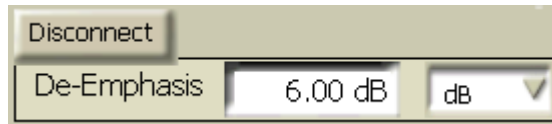

If you could proceed until here, the connection of the user software to the N4916A is ok. If the screen does not show the **De-Emphasis** entry field, there is no connection to the N4916A.

Check the Output of the N4916A Using a Scope

- 1 Set the Data offset to 0 V and the amplitude to 1 V. Set the De-Emphasis to 6 dB.
- 2 Connect the Output of the N4916A to an oscilloscope.
- 3 Connect the trigger output of the Serial BERT to the trigger input of the oscilloscope.

Then the oscilloscope should show an output eye like the following:

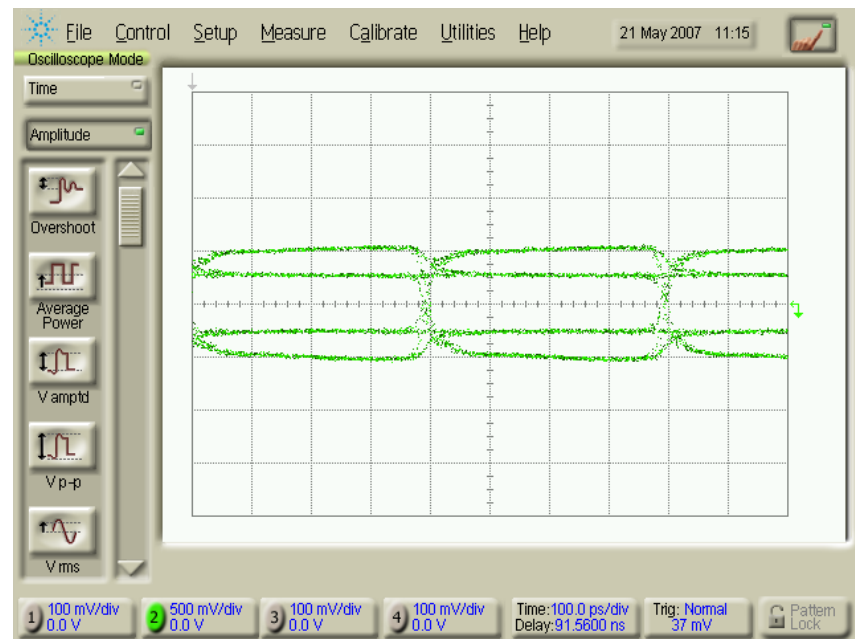

If you see a display like above everything is ok.

If you see merely one fixed level, either the N4916A or the output of the Serial BERT is defective.

Check the Output of the N4916A Using the Error Detector

If you have connected the N4916A to a Serial BERT and have no oscilloscope at hand, you can use the error detector for checking the output of the N4916A.

- 1 Set up the pattern generator as described above: Set the Data Offset to 0 V and the Amplitude to 1 V. Set the De-Emphasis to 6 dB.
- 2 Press **ED Setup** and open the **Sampling Point Setup** page.
- 3 Set up the error detector:

- Press the **Edit** button to enter the **ED Input Setup Dialog**.

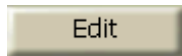

- Set the **Input** to "Normal".
- Set the **Input Range** to -1 V to +1 V.
- Set the **Threshold** to "Averaging".
- Set the **Termination** to 0 V.

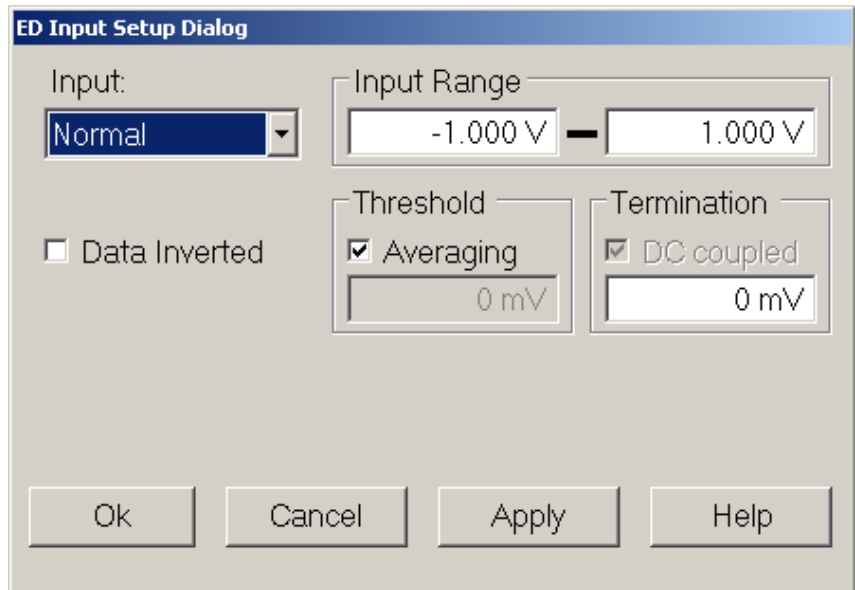

- 4 Connect the Output of the N4916A to the Data Input of the error detector.
- 5 Ensure that the error detector follows the generated pattern.
 - Press the **Auto Align** button.

- From the **Analysis** panel select the **Eye Diagram** page.
- Press the **Start** button.

The eye diagram should look like this after some seconds:

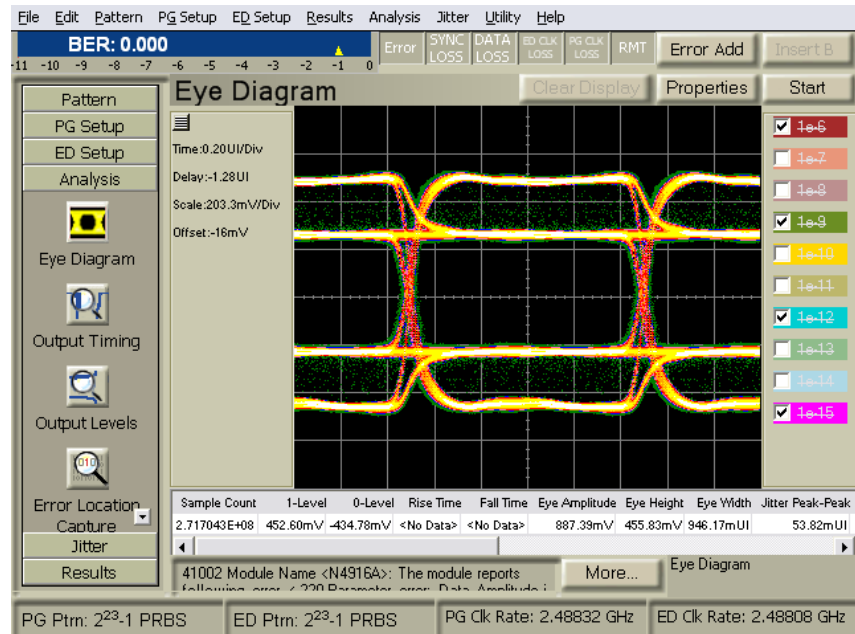

Note that a de-emphasis value of 6 dB causes a 50 percent amplitude reduction.

Check the Output of the Pattern Generator with a Scope

If the N4916A does not produce a signal, check the Data Out of the Serial BERT.

- Connect the Data Output of the pattern generator to an oscilloscope.

NOTE

As long as the N4916A is in "connected" state (after pressing the **Connect** button), the pattern generator's output is programmed to a fixed level. The amplitude is set to 1.2 V, the offset to 0. This yields a signal of ± 0.6 V.

The oscilloscope should show the following picture:

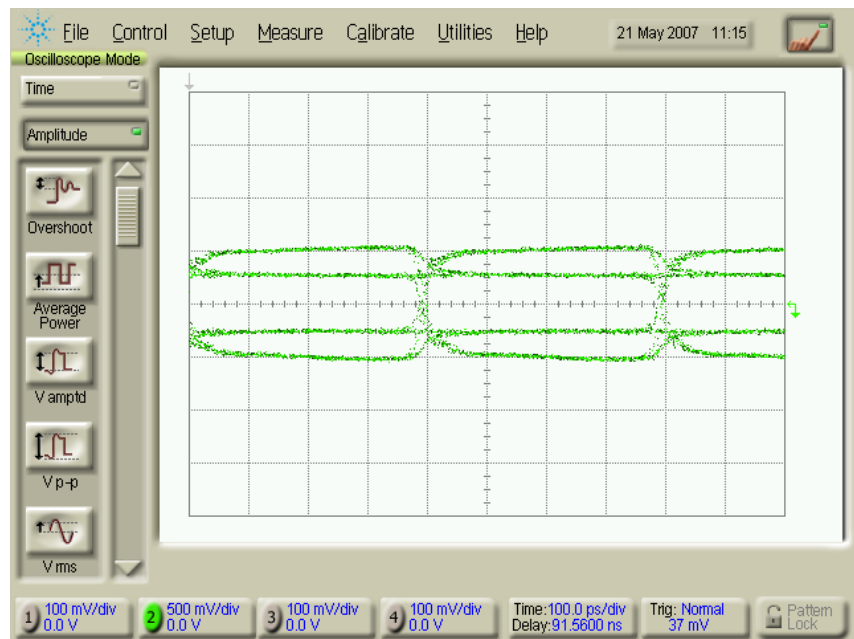

If you see only a straight line, ensure that the pattern generator is not disabled and that it is set up to generate a pattern (e.g. PRBS).

Check the Output of the Pattern Generator with the Error Detector

If you have connected the N4916A to a Serial BERT you can of course check the output of the pattern generator by means of the error detector.

- 1 Set up the pattern generator as described above: Set the Data Offset to 0 V and the Amplitude to 1 V.
- 2 Set up the error detector as described above.
- 3 Connect the Data Output of the Serial BERT to the Data Input of the error detector.
- 4 Ensure that the error detector follows the generated pattern.
 - Press the **Auto Align** button.
 - From the **Analysis** panel select the **Eye Diagram** page.
 - Press the **Start** button.

After some seconds, you should see an eye diagram like the following:

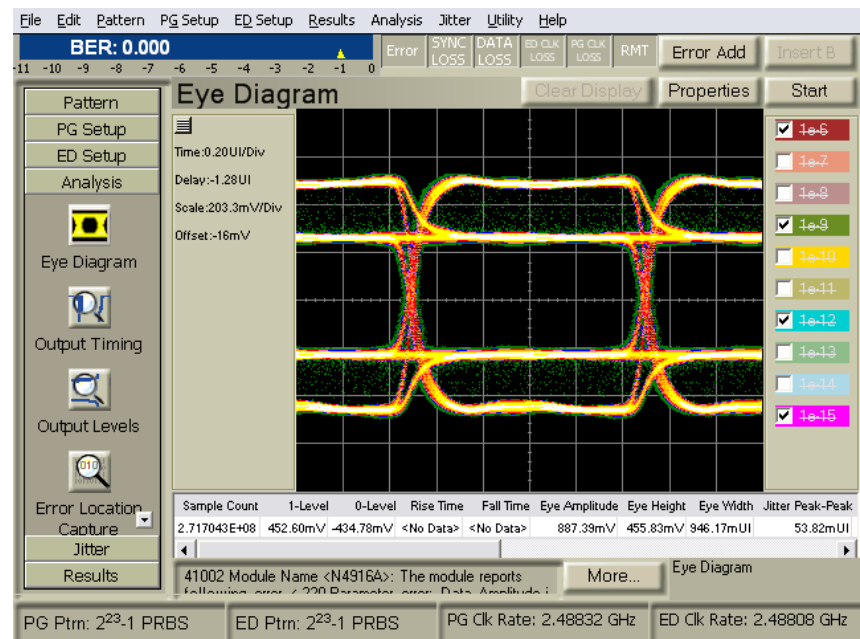

This is the eye of a non-distorted pattern.

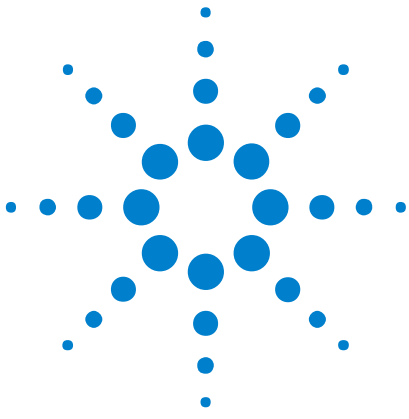

9 Customizing the Instrument

Customizing the Instrument - Concepts

The Serial BERT provides various utilities for adjusting the instrument to your personal preferences.

Restoring the System

Restoring the System - Procedures

Although any bootable diskette created on another PC with either Windows 98 or Windows XP can be used for emergency repair of your system, we strongly recommend to create the bootable diskette at your system.

Store the diskette on a safe place and use it to restore the operating system to its factory state.

CAUTION

When the operating system is restored, all personal settings, programs and user data will be lost. Make sure that important data is saved to external media before restoring the system.

How to Create a Bootable Diskette

- 1 Minimize the Serial BERT user interface window by selecting **Minimize GUI** from the **Utility** menu.
- 2 Place a blank diskette in the instrument's floppy disk drive.



- 3 Click **Start**, and then click **My Computer**.
- 4 In the file browser **select** the symbol for drive A:
Do not open the drives folder, only select it.
- 5 Select **Format** in the **File** menu.
- 6 Make sure that the title of the dialog box is **Format Floppy (A:)**.

CAUTION

Do not format any other drive but the floppy drive.

- 7 Click **Create an MS-DOS startup disk**.
- 8 Click **Start** and follow the instructions.

NOTE

The MS-DOS startup disk only allows the system to boot into an MS-DOS prompt. The disk contains no additional tools and is not a substitute for Windows XP Setup Boot Disks.

How to Restore the Operating System

- 1 Turn off the instrument and connect a keyboard and mouse to the instrument. See “[Connecting Peripherals](#)” on page 399 for details.
- 2 Insert the bootable diskette in the floppy drive.
- 3 Turn on the instrument.
- 4 On the command prompt type `d:` and press **ENTER**.

NOTE

Depending on the format of the harddrive the backup image may appear on drive letter `c:` instead of drive letter `d:` when booted into MS-DOS. If you get an error message using the command above type `c:` followed by **ENTER** and proceed with step 5.

- 5 Type `recover`, press **ENTER** and follow the instructions.

Configuring the Instrument

Configuring the Instrument - Concepts

This section covers information on the configuration of the Serial BERT.

Updating the Software

New software features are offered for the Serial BERT from time to time; you may be able to enhance the capabilities of your instrument by updating the software.

See the Agilent Serial BERT web site to see if updates are available for your instrument:

<http://www.agilent.com/find/SerialBERT>

Besides the latest versions of the user interface and firmware server, you will also find instructions for the update process.

CAUTION

Before you update the instrument's software, make sure that the software matches the instrument's hardware. An update can be carried out, even if the software does not match the hardware. In this case the instrument may go into a corrupt state or not all features may be available.

The applicable hardware versions are listed with the software update version. You can find the instrument's hardware version on a label at the rear panel.

General Notes to Updating the Firmware Server

When updating the firmware server on the instrument, make sure you select the **Hardware** installation option.

After the firmware server has been updated, you are prompted to start a BIOS update. Allow the BIOS to be updated (the firmware server requires the modifications). Do not interrupt the BIOS update.

Note that you must reboot the instrument after updating the firmware. If you do not reboot the instrument, the firmware may not have access to the instrument's hardware.

Configuring the Instrument - Procedures

Follow the instructions below to configure the instrument according to your personal needs:

Setting Date and Time

Your instrument uses the date and time when:

- Saving files
- Saving self test information
- Saving calibration information

To set the date and time of your instrument, do the following:

- 1 On the **Utilities** menu, click **Set Time and Date...** This opens the **Date/Time Properties** dialog box.
- 2 Set the date and time.
- 3 Click **OK**.

Setting the GPIB Address

Your instrument is set to a default GPIB (General Purpose Interface Bus) address. You can change this address by doing the following:

- 1 On the **Utilities** menu, click **Change GPIB Address....** This starts the **GPIB Address Change** dialog box.
- 2 Select an address in the **New GPIB Address** list.
- 3 Click **OK**. The new address will be applied and the dialog box will close.

Each instrument *must* be set to a unique GPIB address to avoid multiple instruments transferring data at the same time.

NOTE

The default address is **14**; however, addresses from **0** to **31** may be used if the default address is the same as another instrument's GPIB address. Address **21** is usually reserved for the computer interface **Talk/Listen** address and should *not* be used as the instrument address.

Connecting Peripherals

You can connect an external monitor, mouse and keyboard to the instrument on the Serial BERT's rear panel. To connect a mouse or a keyboard, you can use either the USB ports or the PS/2 ports.

For more details refer to [“Using an External Monitor” on page 402](#) and [“Using the On-Screen Keyboard” on page 402](#).

NOTE

If the touchscreen is disabled, the external keyboard and mouse are also disabled. See [“Turning the Touchscreen Off/On” on page 401](#) on how to enable/disable the touchscreen.

NOTE

If caps lock is pressed on the keyboard, this will also affect the frontpanel keys, i.e. M(ega) and m(illi) will be exchanged!

Enabling the LAN Connectors

You can enable the LAN connection on your Serial BERT. This will allow you to connect to network printers and remote servers with access to shared folders and files.

The Serial BERT has two RJ-45 LAN connectors on the rear panel. They support 10 Base-T and 100 Base-T Ethernet networks using TCP/IP and other Microsoft supported networking protocols. The Serial BERT uses Microsoft® XP Pro.

For detailed instructions on how to enable the LAN connectors, please refer to the Microsoft® XP Pro manual.

CAUTION

Because your network settings are unique to your IT infrastructure, Agilent Technologies will not be able to assist you with connecting your instrument to your network. Please contact your network administrator or IT department for assistance. For more information, refer to the MS Windows resource kit (available from Microsoft) that is appropriate for your computer system.

CAUTION

Do not connect the Serial BERT to a network that is configured to automatically install software on network devices. Installing or overwriting files on the Serial BERT computer system may impact the operation of the instrument. Please contact your network administrator or IT department to find out whether you have this type of network.

Configuring the Instrument - Reference

The Serial BERT has the following utilities for configuring the instrument:

Set Date/Time Dialog Box

This function opens the Date/Time Properties dialog box of Windows®. Use this dialog box to set the date and time as well as the time zone of your location.

GPIB Address Change Dialog Box

Your instrument is set to a default GPIB (General Purpose Interface Bus) address. You can change this address by doing the following:

- 1 On the **Utilities** menu, click **Change GPIB Address...** This starts the **GPIB Address Change** dialog box.
- 2 Select an address from the **New GPIB Address** list.
- 3 Click **OK**. The new address will be applied and the dialog box will close.

Each instrument *must* be set to a unique GPIB address to avoid multiple instruments transferring data at the same time.

NOTE

The default address is **14**; however, addresses from **0** to **31** may be used if the default address is the same as another instrument's GPIB address. Address **21** is usually reserved for the computer interface **Talk/Listen** address and should *not* be used as the instrument address.

Configuring the Touchscreen

Configuring the Touchscreen - Procedures

The following procedures help you to configure the touchscreen according to your personal needs:

Turning the Touchscreen Off/On

This function disables the instrument touchscreen, external keyboard, and mouse.

- 1 On the **Utilities** menu, click **Touchscreen Off**. The Enable Touchscreen icon is placed in the upper right hand corner of the instrument display.



- 2 Click the Enable Touchscreen icon to enable the touchscreen, keyboard, and mouse again.

Calibrating the Touchscreen

In normal usage, you should not need to calibrate the touchscreen display. But, if you feel that it needs to be realigned with the video display, do the following:

- 1 If the title bar of the Serial BERT user interface is not visible, select **Title Bar** from the **Utility** menu.
- 2 Minimize the Serial BERT user interface window.
- 3 In the system tray, next to the clock in the lower right corner, right-click the **Touchscreen Settings** icon to open the menu with the available options.

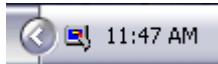

- 4 Select **Calibrate**, then **Device 1**, and **Normal**. A blank screen with a target appears.
- 5 Click the target to start the calibration. When the calibration is complete, the calibration window will close.

Configuring the Double Click

You can adjust the behavior of the touchscreen display to simulate the double-click action of a typical personal computer or trackball. To configure the touch settings:

- 1 Select **Display Utility** from the **Utility** menu. This opens the **Configuration Utilities** dialog box.
- 2 Click **Display** to open the **Display Area Configuration** dialog box.

- 3 Click the **Timed Double Touch** slide bar to adjust the amount of time that can pass as you touch the display screen. You can preview your adjustment by clicking/touching the **Test Box**.

Using the On-Screen Keyboard

You can use the on-screen keyboard to enter text in any text field. It can be used along with the standard keyboard or keypad.

- 1 Click in a text field to position the cursor in it.
- 2 Press the **On-Screen Keyboard** button to open the on-screen keyboard.
- 3 Click letters or numbers as desired. For numbers, you must add the unit by pressing the **G/n**, **k/m**, **M/μ**, or **x1** front panel button.
- 4 Press the **On-Screen Keyboard** button again to close the on-screen keyboard.
- 5 Continue with your work.

NOTE

You can also access the on-screen keyboard from the **Utilities** menu. A check mark appears next to the menu entry, indicating that it has been selected.

Using an External Monitor

To switch between the Serial BERT's built-in display and an external monitor, do the following:

- 1 Connect the external monitor with an appropriate power supply and with the VGA connector on the Serial BERT's rear panel.
- 2 If the title bar of the Serial BERT user interface is not visible, select **Title Bar** from the **Utility** menu.
- 3 Minimize the Serial BERT user interface window.
- 4 In the system tray, next to the clock in the lower right corner, right-click the **Display** icon to open the menu with the available options.

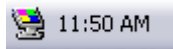

- 5 Select **Graphics Options**, then **Output To**, and the desired output device:
 - **Monitor** for an external monitor
 - **Notebook** for the built-in display

Use the same procedure to switch back to the built-in display.

Configuring the Touchscreen - Reference

This section describes the options of the on-screen keyboard:

Click **Set** to access the **Options** menu:

- **Move OSK Window**

Click this to enable the arrow keys on your actual keyboard. They can then move the software keyboard.

TIP

You can always move the **On-Screen Keyboard** window by clicking its title bar and dragging it.

Additionally, you can switch between different views of the on-screen keyboard. The following table lists the displayed buttons for the different views:

Table 28

	Softkeys	Letters	Numeric	Characters
Qwerty Full	X	X	X	X
Qwerty Simple		X	X	X
Qwerty Minimum		X		X
Block Full	X	X	X	X
Block Simple		X	X	X
Block Minimum		X		X
Minimum		X		

NOTE

Qwerty options mimic the layout of an actual keyboard. **Block** options present the letter characters in alphabetical order.

TIP

If you select one of the larger on screen keyboard displays, such as **Qwerty Full** or **Block Full**, the keyboard may cover most of the instrument display. If this occurs, continue to make your keyboard entry, then either close the on screen keyboard or change to a smaller display.

Installing Software Licenses

Installing Software Licenses - Procedures

The Serial BERT has optional features that require a license. The following procedures explain how to obtain and install a license:

Obtaining a License

To obtain a license:

- 1 In the **Utilities** menu, click **Licenses**. The **Licenses** dialog informs you about the options that require a license.
- 2 Record the HOST ID / MAC Addr shown in the window. This is the MAC Address of the Serial BERT.
- 3 Contact your Agilent representative and purchase a Software Entitlement Certificate.
- 4 Visit the website .
- 5 Follow the instructions on the website. You will need the certificate and the MAC Address.
- 6 You will receive a licence file over the web. The file has the suffix `.lic`.

Installing a License

To install a license:

- 1 Copy the licence file to the Serial BERT.
- 2 In the **Utilities** menu, click **Licenses**.
- 3 Double-click the feature you wish to enable.
- 4 Follow the instructions in the window.

Installing Software Licenses - Reference

This section explains the options for installing a license.

Licenses Dialog

The **Licenses** dialog informs you about the options that require a license.

The HOST ID / MAC Addr shown in the window is the MAC Address of your Serial BERT. You will be asked for this address when you request a license file for an option from Agilent.

NOTE

The MAC Address is used for generating the license key code. That means, the key stored in the license file refers to just one instrument. If you wish to enable a licensed feature on a different instrument, you need another license file.

NOTE

License handling is only available if both NIC (Network Interface Card/Adapter) are enabled.

Install License

The **Install License** dialog is used for installing a license.

It indicates the feature that has been selected before opening the window and allows you to browse for the associated license file.

The suffix of a license file is `.lic`.

If the license file has not been copied to the Serial BERT and is not accessible via LAN, click the **Enter** button.

Enter License Key

This dialog allows you to enter the license key manually.

That means, you need to read (and probably print) the license file with a text editor and type the key code.

Installing Hardware Options

Installing Hardware Options - Procedures

The Serial BERT has a slot for installing optional hardware.

At the present time, the J20 Interference Channel is available. This module can be used for adding intersymbol interference and sinusoidal interference to the signal generated by the Pattern Generator.

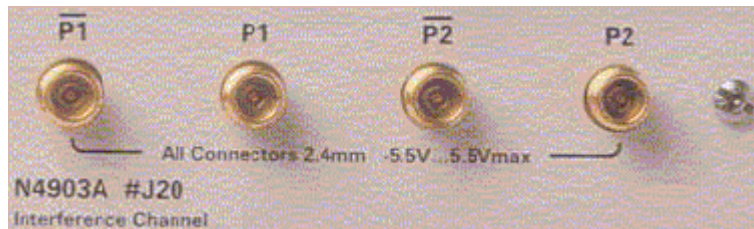

Installing the J20 Option

To install the J20 Interference Channel:

- 1 Perform the regular shutdown procedure provided by the operating system.
- 2 Disconnect the instrument from mains.

CAUTION

Never plug in or remove a module while the instrument is connected to mains power.

- 3 Unscrew and remove the slot cover.
- 4 Insert the module into the slot.
- 5 Press the lever until the module rests firmly in place, the front plate aligned with the Error Detector's front panel.
- 6 Insert and tighten the fixing screw.
- 7 Power up the instrument. The software will automatically recognize the new component and provide the Interference Channel Icon and according setup functions in the **Jitter** window.

Connecting the J20 Option

The J20 Interference Channel has two ports, P1 and P2. They can be connected single-ended or differentially. For a description see “Interference Channel” on page 323

If you connect P1 to the Data Out of the Pattern Generator, P2 provides the output that is meant to be connected to the DUT. This is illustrated in the following figure.

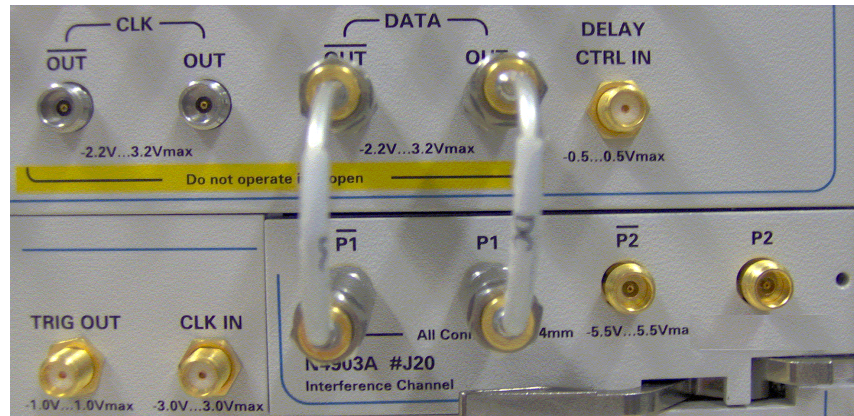

If you connect P2 to the Data Out of the Pattern Generator, P1 provides the output.

CAUTION

The module has golden 2.4 mm connectors. Be sure to use the specific cables or adapters for the connections. Improper connection can damage the module.

Installing the N4916A

Installing the N4916A - Procedure

The N4916A De-Emphasis Signal Converter is an optional instrument that can be connected to the Serial BERT. For general information see “Understanding the N4916A De-Emphasis Signal Converter” on page 77.

When you install the N4916A for the first time, you need to configure the USB interface of the Serial BERT.

For this configuration, you may wish to connect a keyboard and a mouse to the Serial BERT (see [“Connecting Peripherals” on page 399](#)). This is not mandatory but convenient – the keys provided by the instrument can be used as well for entering the required information. You can remove keyboard and mouse when you are done.

Checking the Serial BERT Software Revision

The Serial BERT software supports the N4916A on from revision 4.8.

- 1 Switch on the Serial BERT.
- 2 In the **Help** menu, click **About**.
- 3 If the software revision is below 4.8, you need to update the software (see [“Updating the Software” on page 397](#)).

Checking the Agilent IO Libraries Revision

New Serial BERT instruments are delivered with Agilent IO Libraries Suite Revision 14.1 or later installed. However, the N4916A can also be operated with the older revision M.01.

- 1 In the **Utility** menu, click **Minimize GUI** to access the Windows operating system.
- 2 Click the **Agilent IO Control** icon in the Windows task bar to open the IO Control menu.



If the software revision is below 14.0, you see the menu item **Run IO Config**.

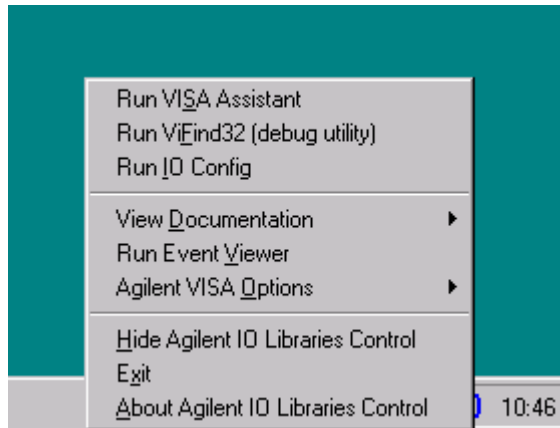

If the software revision is 14.0 or later, you see the menu item **Agilent Connection Expert**.

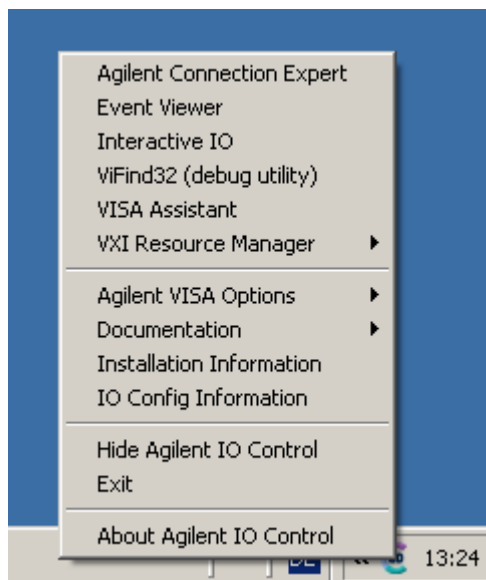

3 Click the **About** item to check the details.

If you wish to update the Agilent IO Libraries Suite, you can download the software from

<http://www.agilent.com/find/iolib>.

Installation instructions are given in the associated Readme file.

Connecting the N4916A via USB

The N4916A is controlled by the Serial BERT via USB.

- 1 Connect mains power to the N4916A and switch the instrument on.

NOTE

When you connect the N4916A via USB, it is important that the N4916A is switched on. Otherwise, it may not be identified correctly by the operating system.

- 2 Connect the USB cable between the USB ports at the rear sides of the N4916A and the Serial BERT. You can use any rear port of the Serial BERT.
- 3 The **Found New Hardware Wizard** will pop up and ask whether he should connect to Windows Update.
- 4 Click **No, not this time**.



- 5 Click **Next** and let the Wizard locate the appropriate driver. The USB driver is part of the Agilent IO Libraries Suite.

- Step through the Wizard by clicking **Next**. The Wizard will finally set up a USB device named "USB Test and Measurement Device".



Assigning a VISA Alias Name

Assigning a unique VISA alias name to the N4916A simplifies remote programming and helps to make programs portable. The Serial BERT software requires a specific VISA alias name to access the N4916A.

Using the Agilent Connection Expert The Agilent Connection Expert is available on from revision 14.0 of the Agilent IO Libraries Suite.

- If the Agilent Connection Expert does not pop up automatically, click the **Agilent IO Control** icon in the task bar and open it from the menu.
- In the **Instrument I/O panel**, click **UsbDevice1**. "UsbDevice1" is the default alias name.

- 3 Click **Change Properties** and change the alias name to D4916.

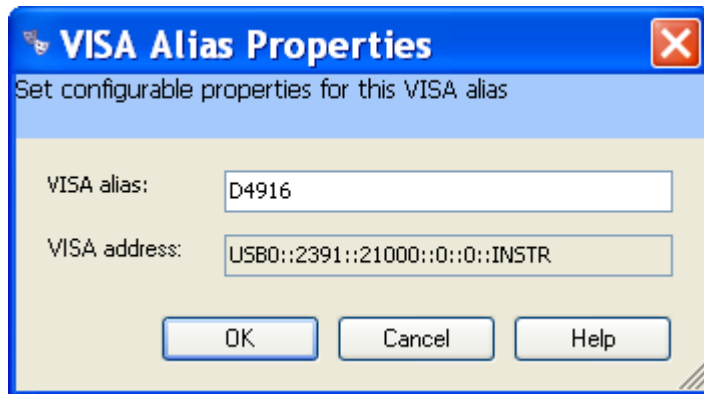

"D4916" is the alias used by the software.

- 4 After clicking OK, the Agilent Connection Expert shows a window like the following:

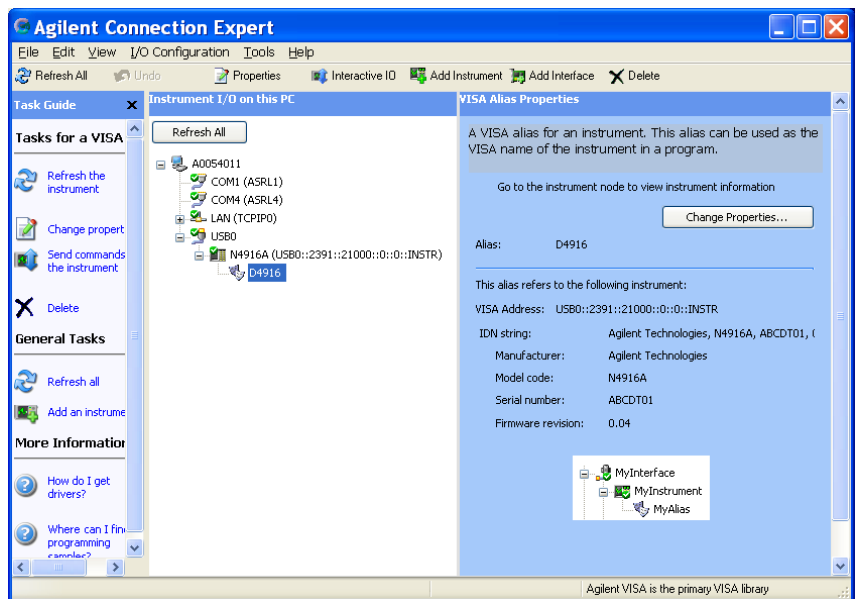

For detailed instructions refer to the Connectivity Guide which is part of the Agilent IO Libraries Suite Documentation.

Using Agilent IO Config

Agilent IO Config is provided up to revision M.01 of the Agilent IO Libraries.

- 1 If Agilent IO Config does not pop up automatically, click the **Agilent IO Control** icon in the Windows task bar and select **Run IO Config**.
- 2 In the list of **Available Interface Types**, select "USB Instruments" and click **Configure**.

- 3 Open the **Edit Alias** window and change the default VISA alias name "UsbDevice1" to "D4916".

The screenshot shows the 'Edit alias' dialog box with the following fields and values:

- Alias name: D4916
- Identification: Agilent Technologies N4916A
- Visa Resource Name:
 - Preferred: D4916
 - Alternate: USB0::2391::21000::0::0::INSTR
- SICL Address String:
 - Preferred: D4916
 - Alternate: usb0[2391::21000::0::0]

Buttons: OK, Cancel

For detailed instructions refer to the online Help.

Connecting to Pattern Generator and DUT

After the USB port has been configured, you can remove keyboard and mouse and make the signal connections.

- 1 Use the N4915A-004 cable or a 2.4 mm cable (m-m) longer than 350 mm and connect the pattern generator's Data Out port to the Input port of the N4916A.
- 2 Mount the SMA 50 Ohm termination on the unused Data Out port of the pattern generator using the SMA to 2.4 mm adapter.
- 3 Enable the De-Emphasis Signal Converter as described in [“Understanding the Output Level Parameters” on page 73](#) and set the levels such that the DUT will not be damaged.

- 4 Use a matched pair of 2.4 mm cables to connect the differential outputs of the N4916A to the DUT. If only one output of the de-emphasis signal converter is needed, connect a 2.4 mm 50 Ohm termination to the unused output.

Installing Webserver

Customizing the Web Server- Concept

What is a Web Server?

A web server is a program that operates by accepting HTTP requests from the network, and providing an HTTP response to the requester.

Enabling a web server on an instrument allows it to accept and respond to HTTP requests from clients. The web server is an industry standard for providing information and functionality of an instrument over LAN.

The web enabled instruments are based on two technologies:

The first technology is the instrument itself. The typical user scenarios for Web Enabled Instruments identify the user as being familiar with the instrument involved. They normally use the instrument to gather data, and make measurements.

The second technology is that of the World Wide Web, and the web browser. User data gathered across target user groups support the hypothesis that the great majority of Electrical Engineers, and supporting technicians are familiar with the web and web browsers. They frequently use one or more web browsers.

An Instrument-Embedded Web Page is defined as a web page that is served up to a Web Browser from an instrument or product. The server may reside either internally in the instrument or externally on a computer that is connected to and interacts with the instrument.

A Web Enabled Instrument or product is defined as one that is enabled to provide a Graphic User Interface (GUI) of the instrument or product in a World Wide Web browser. The GUI provides the user an interface to view and control the instrument or product remotely.

J-BERT provides the option of web server, and installing this program enables users to access the instrument remotely over LAN.

The four basic steps to using a web browser:

- 1 Open the web browser and enter the URL for the target instrument
- 2 The instrument web server responds with the instrument's "Welcome Page", as shown in the screen below.

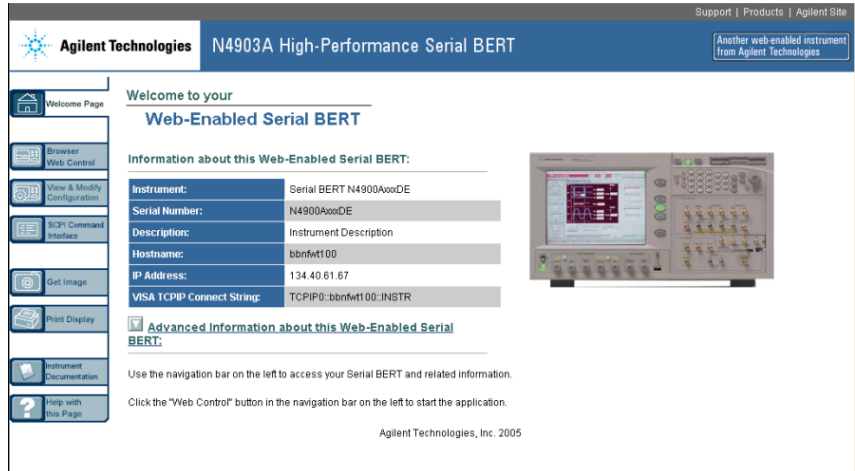

- 3 Click on the left-side link to control/monitor the instrument.
- 4 The browser returns the instrument display and control applet in the main display frame which contains the instrument display and the instrument-centric controls provided in the applet.

How to Install the Web Server

The following steps explain how to download, and install the Web Server.

NOTE

The current J-BERT instrument can be upgraded to the Web Server enabled software.

Follow the steps below to install the web server on the instrument:

- 1 Find "webserver.zip" at the same location as the N4903 software, and download it. To download it you can right click on the link and select 'save target as'.
- 2 Unzip the folder, because the installation can be started from an unzipped folder. Install the Web Server software. Follow the instructions prompted by the installation process.
- 3 Launch N4903 software. Click 'Utility' on the toolbar. The following drop down list will appear.

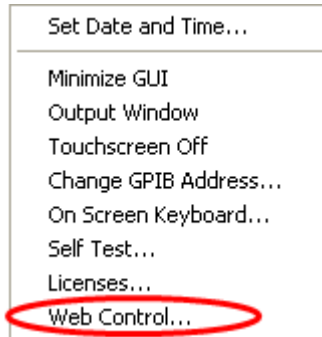

The WebControl dialog provides the user with the current IP address of the instrument. The IP address can be used on the internet explorer to address the instrument. Additionally the WebServer running on the instrument can be enabled/disabled, and a password can be specified. Without a valid password you can not access the instrument's GUI. The following screen displays the WebControl dialog.

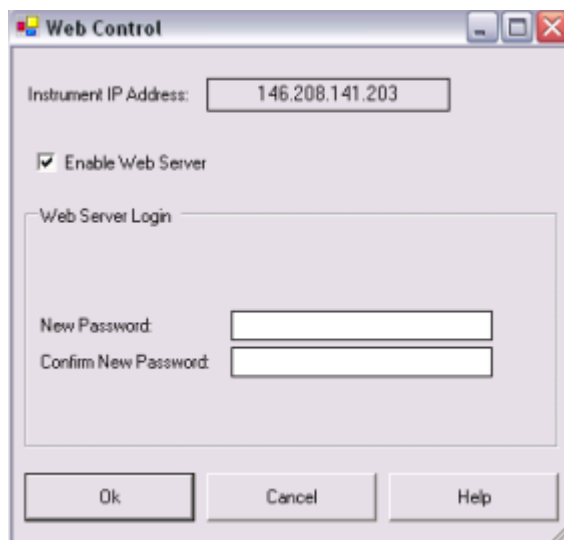

- 4 On the web control dialogue shown above you can request for help by pressing the 'Help' button on the lower right hand corner.
- 5 The instrument IP will be automatically generated in the space labeled 'Instrument IP Address'. While adding the instrument on the network the IP address will be defined. The DHCP protocol automates the assignment of the IP addresses. The read only lable in the WebControl dialog shows the current IP address of the instrument, and this can be used to address the instrument on the internet explorer by the web client. Enter a password which will be used for authentication.

Follow the steps below to access the instrument through the web server:

NOTE

- You need to know the instrument IP address and the password.
- Additional to the WebBrowser a JAVA runtime environment has to be installed on the client computer. If the Java runtime environment is not installed on the client computer you cannot access the GUI of the instrument.
- If Framework 2.0 is installed on the instrument you need to uninstall it. Framework 2.0 comes with the WebServer installation.

- 1 Open a web browser, either Internet Explorer 4.0 or higher, or Netscape 4.0 or higher.
- 2 Type in the instrument IP, and enter the password when it prompts for it.

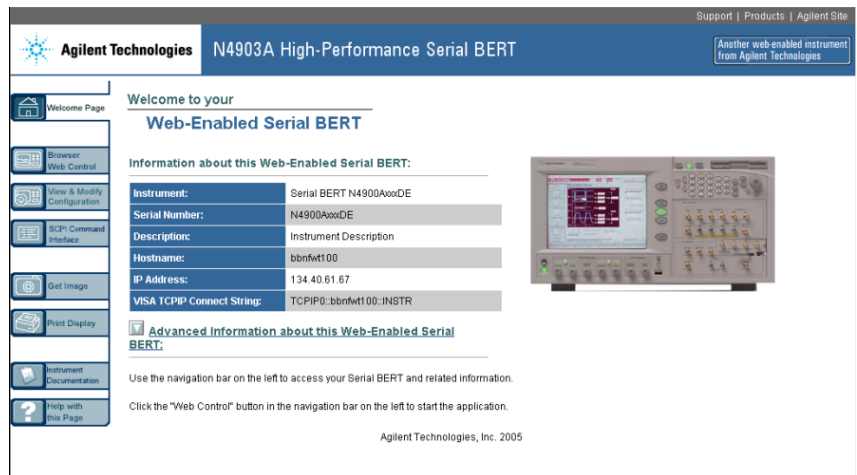

- 3 From this page you can access all the functionalities of the J-BERT.

Printing

Printing - Procedures

This section provides information on setting up and using a printer:

Connecting a Printer to the Instrument

The instrument supports parallel and serial printers as well as USB and LAN connected printers.

To connect your printer to the instrument:

- 1 Turn off power to the instrument and printer before connecting.
- 2 Connect the printer to the instrument with the cable that came with your printer.

Once you have connected the printer to the instrument, you will need to add the printer driver before you can use the printer.

Adding a Printer

Use the following procedure to add a printer to the instrument.

- 1 On the **File** menu, click **Print Setup**, then **Add Printer...** This opens the **Add Printer Wizard** dialog box.
- 2 Click **My Computer** for a local printer installation, or click **Network printer server** for a printer connected to another server.

NOTE

Before you can add a network printer, you must connect to a Local Area Network (LAN). In addition, your login must provide you with access to the network printers that you wish to add. Please contact your network administrator or IT department for assistance.

- 3 Follow the instructions in the **Add Printer Wizard** until you have selected a local printer and configured the printer port.
- 4 If your printer is not in the list of available printers, you will need a copy of the printer driver. Select a printer from the displayed list and click the **Have Disk** button.

The instrument will then prompt you to put your printer driver disk into the floppy disk drive (drive A:\).

- 5 Follow all other instructions.

Removing a Printer

When you disconnect a printer from the instrument and no longer intend to use it, you can remove the printer driver and increase the free disk space available on the instrument's internal hard disk drive.

To remove a printer driver:

- 1 On the **File** menu, click **Print Setup**, then **Configure Printer...** This opens the **Printers** dialog box.
- 2 Click the printer driver you want to remove.
- 3 In the **File** menu in the **Printers** dialog box, select **Delete**. A dialog box will appear to confirm the removal of the printer driver.
- 4 Click **Yes** to confirm your selection.

Setting the Default Printer

You can set the printer you use most often as the default printer. Then all printouts will be sent to the default printer unless you explicitly select another printer.

To specify the default printer:

- 1 On the **File** menu, click **Print Setup**, then **Configure Printer...** This opens the **Printers** dialog box.
- 2 Choose one of the currently mapped printers. If the printer you want to use is not yet included in this list, see [“Adding a Printer” on page 418](#).
- 3 On the **File** menu in the **Printers** dialog box, click **Set As Default**.
- 4 Click **Close**. The default printer selection is applied and the dialog box closes.

NOTE

The printer capabilities will vary depending on the printer you have installed and configured.

Printing a Hardcopy

NOTE

Before you can print, you must first have the appropriate printer driver installed. The printer properties and capabilities will vary depending on the printer you have installed and configured for the instrument.

To print a hardcopy of the instrument's display to the default printer:

- Click **Print** from the **File** menu on the main menu bar.

Configuring Printer Properties

You can change the properties of a selected printer:

- 1 On the **File** menu, click **Print Setup**

- 2 Click **Configure Printer...**

This opens the **Printers** dialog box

- 3 In the **File** menu in the **Printers** dialog box, select from the following options:

- **Server Properties**

Click this option to change such items as printer margins, spooler warnings and alarms, and port configurations.

- **Properties**

Click this option to change such items as pre-determined access times, security items, and LAN protocols.

- **Document Defaults**

Click this option to change such items as pages per sheet, print quality, paper select, and portrait vs. landscape layouts.

- 4 Select **Close** in the **File** menu of the **Printers** dialog box.

The new settings will be applied and the dialog box closes.

NOTE

The printer properties and capabilities will vary depending on the printer you have selected.

Printing Problems

You should check the following when your printer fails to print:

- 1 Check if the printer is turned on and the printer cable is securely attached to both the printer and the instrument's printer connector.
- 2 Check if the printer driver for your printer is installed.
- 3 Check if the printer port is configured correctly.

For more information on printer problems, see the printer's operation manual.

File Management

File Management - Procedures

This section provides information on saving and recalling instrument states, log files, patterns, and screenshots.

You can save the files on the local disk. Note that the local disk must not be re-partitioned in a Windows 2000 environment.

You can also plug an USB stick into the rear of the instrument for saving and recalling files. No driver is required because Windows has a built-in driver that supports USB memory drives. In the file browser, you can access the USB stick via the **Removable Disk** drive.

To avoid loss of data, stop the USB device and wait until the LED light of the USB stick is off before unplugging the USB stick.

To avoid loss of data when removing the USB stick:

- 1 Minimize the GUI.
- 2 In the system tray, next to the clock in the lower right corner, right-click the **Safely Remove Hardware** icon.
A window containing a list of the USB devices appears.
- 3 Click on the popup message **Safely Remove Mass Storage Device**.
- 4 Confirm the acknowledgement message **Save to remove hardware....**
- 5 Check that the LED light of the USB stick is off and unplug the USB stick.

Saving Instrument States

Saving the current instrument state stores all the setup parameters for the instrument's hardware and software.

To save the setup with the current filename and directory path, do the following:

- In the **File** menu, click **Save** and then **Save Instrument State....** The current instrument state will be immediately saved.

To save the setup with a new filename or directory path, do the following:

- In the **File** menu, click **Save** and then **Save Instrument State As....** This opens a dialog box, which allows you to create subdirectories, rename setup files, or overwrite existing setup files.

NOTE

Ensure your instrument state files have the extension, ***.btz**. If you do not specify an extension or use a different extension, the instrument may not recognize the file as an instrument state file.

NOTE

The default pathname for user defined instrument states is C:\N4903A\Settings

The number of instrument states you can save is limited only by the available space on the internal hard disk or floppy disk. Each instrument state uses approximately 6 kB of disk space.

TIP

Remember to always make a backup copy of your files. If your original files are damaged or lost, you can restore the files from the backup copy.

Recalling Instrument States

Recalling the instrument state restores all the setup parameters for the instrument hardware and software.

To recall the setup, do the following:

- In the **File** menu, click **Open** and then **Open Instrument State....** This opens a dialog box which allows you to select the setup file you want to recall.

TIP

Remember always to make a backup copy your setup files. If your original files are damaged or lost, you can restore the files from your backup copy.

NOTE

The default pathname for user defined instrument states is C:\N4903A\Settings

Saving and Recalling Measurement Logs

Measurement Logs are saved as CSV (comma-separated values) files. Follow the steps below to view results in a measurement log file.

- 1 Copy the measurement log file from the Serial BERT to your PC. By default, log files are saved in the folder C:\N4903A\log.
- 2 Open a spreadsheet application on your PC.
- 3 Import the measurement log file. If your application has an import wizard, you may need to indicate that data is delimited with commas.
- 4 Once the file has been imported, you may need to resize columns. The imported log file should appear similar to the following example.

NOTE

During measurement logging, the Serial BERT logs data in ten-second intervals. Your log file may be missing up to the last ten seconds of data. To avoid this condition, accumulate for 10 seconds longer than desired.

	A	B	C	D	E
1	Description: test				
2	Log Time: 05/29/2000 12:14:58.334				
3	Activation Mode: Single				
4	Accumulation Measurement: ELAPSED_SECONDS				
5	Accumulation Limit: 60.000000				
6					
7	Elapsed Time		BIT COUNT	BIT FREQUENCY	ED FREQUEN
8	0.1		2.49E+08	2.49E+09	2.49E+
9	0.2		2.49E+08	2.49E+09	2.49E+
10	0.3		2.49E+08	2.49E+09	2.49E+
11	0.4		2.49E+08	2.49E+09	2.49E+
12	0.5		2.49E+08	2.49E+09	2.49E+

You can view and analyze the following information in the measurement log file:

Table 29

Instantaneous	Cumulative
BIT COUNT	BIT COUNT Cumulative
ERROR COUNT	ERROR COUNT Cumulative
ERROR RATIO	ERROR RATIO Cumulative
ERRORED 0 COUNT	ERRORED 0 COUNT Cumulative
ERRORED 0 RATIO	ERRORED 0 RATIO Cumulative
ERRORED 1 COUNT	ERRORED 1 COUNT Cumulative

Table 29

Instantaneous	Cumulative
ERRORED 1 RATIO	ERRORED 1 RATIO Cumulative
SYNC LOSS	ERROR SECONDS Cumulative
PG CLOCK LOSS	ERROR FREE SECONDS Cumulative
ED CLOCK LOSS	ERROR DECISECONDS Cumulative
DATA LOSS	ERROR FREE DECISECONDS Cumulative
	SYNC LOSS SECONDS Cumulative
	BURST STATUS Cumulative
	BURST SYNC RATIO Cumulative
	TOTAL BURST COUNT Cumulative
	BAD BURST COUNT Cumulative

Saving and Recalling Patterns

You can save your pattern in either of the following ways:

- Click the **Save** icon on the **Pattern Editor** toolbar.



If the pattern has not been saved earlier, a file dialog box opens that allows you to navigate the file system and name your pattern.

Alternatively, you can use the following procedure:

- 1 From the **File** menu, select **Save**.
- 2 Then select **Save Pattern in Editor....** to save the pattern with the current filename. Or click **Save Pattern in Editor as....** to open a file dialog box that allows you to save the pattern with a new name.

NOTE

The default pathname for patterns is C:\N4903A\Patterns.

Saving and Recalling Screen Images

The instrument allows you to save an image of the current display screen. You can save this image to the internal hard disk or a floppy disk. You can later print this file or import it to a word processing or graphics editing program.

Saving To save an image of the display screen, do the following:

- 1 In the **File** menu, select **Save**.
- 2 Select **Save Screen Capture....**

This opens a dialog box, which allows you to save the image as a *.bmp (256 color bitmap file format) file.

Recalling Follow the steps below to view screen images on an external PC:

- 1 Copy the screen image file from the Serial BERT to your PC. By default, image files are saved in the folder C:\N4903A\User.
- 2 Open the file in Microsoft Paint or another graphics program.

Preset Instrument State

Preset Instrument State - Procedures

To reset the instrument to the preset state select one of the following options:

- Press the **Preset** button on the front panel.
- or
- Select **Preset** in the **File** menu.
- or
- Send an *RST command to the GPIB controller.

Self Test

Self Test - Concepts

The self test checks specific hardware components for basic functionality. At initialization, the following self tests are automatically run:

- Pattern Generator Power Up Test
- Error Detector Power Up Test

NOTE

The current system state is saved and the instrument is re-initialized before performing the selected tests. The saved system state is restored upon completion of the self test.

When **Self Test** is selected from the **Utility** menu, the **Self Test Options** dialog box opens. In this dialog box, you can select additional self tests that will run when you click **Run Test**.

NOTE

During accumulation or while auto-search functions are in progress, **Self Test** is not available.

The pass/fail results of the self test are displayed in the **Self Test Options** dialog box. In case of failed tests, you can view detailed error messages in a separate window.

Self Test - Procedures

To run a self test:

- 1 Select **Self Test** from the **Utility** menu.
This opens the **Self Test Options** dialog box.
- 2 Select the desired tests and click the **Run Test** button.
- 3 After the self test has finished, the results are displayed next to each selected test.

- 4 If a test failed, you can view detailed error messages by clicking the respective **Message** button.

Self Test - Reference

This section contains information about the **Self Test Options** dialog box used for setting up and running a self test and for viewing the results.

Self Test Options

The **Self Test Options** dialog box offers to select the following tests:

- **Pattern Generator Bios Self Test**

This test is checking all the modules, chips, and registers of the **pattern generator** more thoroughly than the Power Up test. It may take about 5 minutes to complete.

- **Pattern Generator Power Up Messages**

This test is automatically run after switching on the instrument. It mainly checks if all important modules, chips, and registers of the **pattern generator** are available and accessible.

- **Pattern Generator Auto Calibration**

This test runs a timing calibration that calibrates the clock to data alignment of the **pattern generator**. It may take about 15 minutes to complete.

- **Error Detector Bios Self Test**

This test is checking all the modules, chips, and registers of the **error detector** more thoroughly than the Power Up test. It may take about 5 minutes to complete.

- **Error Detector Power Up Messages**

This test is automatically run after switching on the instrument. It mainly checks if all important modules, chips, and registers of the **error detector** are available and accessible.

- **Error Detector Auto Calibration**

This test runs a timing calibration that calibrates the clock to data alignment of the **error detector**. It may take about 15 minutes to complete.

Select All/Unselect All

Use the **Select All** button to select all tests in the **Self Test Options** dialog box. After clicking the button, it becomes the **UnselectAll** button. Clicking the button again will then unselect all tests and display the **Select All** button again.

Run Test

After selecting at least one test, use this button to start the test. If you selected tests, that need a longer time to complete, a message box opens. Confirm your selection by clicking **OK**. A second message box is informing you while the test is still running and closes when finished.

Message Buttons

After the self test has finished, the results (**Success** or **Failed**) are displayed next to each test. If a test has failed, you can use the **Message** button to open the **BIOS Messages** window with detailed error messages explaining the failure reason.

Index

0/1 Decision Threshold, 130
0/1 Threshold, 131
0/1 THReshold Center button, 133
0V (Disable) button, 85
10 MHz Ref Input, 70

A

Absolute threshold, 247
AC Coupling, 76
Accumulated Measurements, 302
 Results, 304
 Running, 303
Accumulated Results, 306
Accumulation Parameters, 308
Accumulation period, 153
Adjust Output Levels, 80
Advanced Analysis, 159
Alternating Patterns, 102
Amplifier Connections, 19
Amplitude, 211
Audio Signals, 156
Auto Align button, 132
Auto Threshold
 Error Detector, 125
Aux In, 71
Aux Out
 Error Detector, 138
Auxiliary Out port, 112
Auxiliary Output, 136
Average 0/1 Threshold, 135

B

Bathtub curve, 174
BER, 10
BER Location, 154

BER Results
 Analyzing, 299
 Monitoring, 299
BER Results Window, 300
BER Threshold
 Eye Opening, 233
 Output Levels, 208
 Output Timing, 190
 Sampling Point Setup, 134
BER values, 254
BER vs. Threshold Graph, 207
Bias Tees, 76
Bit Rate
 Different In/Out Rates, 18
 Pattern Generator Setup, 87
Bit Rate Range
 Error Detector, 119
Bit Recovery button, 135
Bit Recovery Mode
 enable, 131
 explanation, 128
Bounded uncorrelated jitter (BUJ), 318
Bracketing Approach, 180
BRM, 128
BUJ, 318
Burst Results, 309
Burst Sync Mode, 144

C

Cancel button, 134
CDR, 117
Clock Data Recovery, 117
Clock Falling Edge button, 132
Clock In port
 Error Detector, 111
Clock In termination, 113
Clock Input, 70
Clock Out port, 71

Clock Rate
 Error Detector, 123
Clock Rate Indicators, 93
Clock Setup
 Error Detector, 121
Clock Source
 External, 91
 Internal, 91
Clock Termination, 85
Color Tab, 164
Complement, 114
Confidence Levels, 15
Connecting the DUT, 17
Connections
 Amplifier, 19
 DCA, 20
 Different In/Out Rates, 18
 Differential Inputs, 18
 External Data Source, 21
 Flip-Flop, 19
 MUX/DEMUX Pair, 20
 N4916A, 22
 Oscilloscope, 20
 SONET/SDH Receiver, 21
Constant Errors, 379
Contour, 254
Contour plot, 221
Creating New Pattern, 39
Criteria for Moving to the Next
 Measurement Point, 246
Crossover, 73
Crosstalk, 321

D

Data Center button, 133
Data In port, 111
Data Input Delay, 129
Data input delay, 132
Data Input Setup, 114

Index

DATA LOSS, 377
Data Out port, 71
Data Termination, 85
Date and Time, 398
dBER vs. Threshold Graph, 207
DCA
 Connections, 20
De-Emphasis
 Basics, 77
 control, 81
De-Emphasis button, 86
De-Emphasis Signal Converter, 12
Decimal Places
 Eye Opening, 234
 Fast Eye Mask, 249
 Output Levels, 209
 Output Timing, 190
Decision Threshold, 115
Delay, 73, 84
Delay Control Input, 71
Delay Line display, 329
Delay Line selection, 327
Deterministic Jitter, 193
Different In/Out Rates
 Connections, 18
Differential, 114
Differential Inputs
 Connections, 18
Double Click Configuration, 401
DUT Connecting, 17
DUT Output Timing/Jitter
 measurement, 173

E

ED CLK LOSS, 376
Edge Resolution Optimization
 Eye Opening, 230
 Output Levels, 204
 Output Timing, 185
Edit Pattern Window, 43, 62
Editing Patterns, 40
Equal BER at BER Threshold, 222
Error Accumulation, 152
Error Accumulation, 151
Error Add button, 99
Error Add input, 70
Error Addition/Insertion, 99

Error Detector
 1/0 threshold, 115
 Auto Threshold, 125
 Aux Out port, 112
 Aux Output, 136
 Clock In port, 111
 Clock Setup, 116
 Data In port, 111
 Data In setup, 114
 Error Out port, 112
 Gate In port, 111
 Input and Output Ports, 110
 Setup, 109
 Trigger Out port, 112
Error Indicator, 378
Error Insertion
 Constant Rate, 100
 External Signal, 100
 Manually, 99
Error Location Capture measurement, 236
Error Out port, 112
Estimated Total Jitter, 193
Example of an Output Level
 Measurement
 Changing Properties, 202
 Improving the Display, 201
 Running the measurement, 199
Example Patterns, 33
External Clock Source, 91
External Data Source
 Connections, 21
Eye Diagram, 127
Eye Edge, 127
Eye Height, 311
Eye Measurements, 310
Eye Opening measurement, 220
Eye Width, 311

F

False Synchronization, 142
Fast Eye Mask measurement, 241
Fast Total Jitter at BER, 186
Fast Total Jitter measurement, 173
 Explanation, 178
 Numerical results, 195
 Result Display, 194

File Management, 421
Flip-Flop
 Connections, 19

G

G.821 Measurements, 307
Gate In port, 111
Gate In signal timing, 146
Gating, 85
Gauss curve, 170
Gaussian Marker
 introduction, 169
 Output Levels, 207
 Output Timing, 174
Generated Patterns, 53
GPIB Address, 398
Graph Tab
 Eye Opening, 234
 Output Levels, 209
 Output Timing, 190
 Spectral Jitter, 295
Grid, 254

H

Hardware-generated patterns, 23
High Level, 210
High Level Std. Dev., 211

I

Input and Output Ports
 Error Detector, 110
 Pattern Generator, 70
Input Range
 Error Detector, 116
Instantaneous Measurements, 297
Interference Channel, 323
 Setup, 336
Internal Clock Source, 91
Intersymbol Interference, 337
Intersymbol interference (ISI), 320
Interval Results, 308
Introduction to the Serial BERT, 9
 invalid, 194

Inverted Data
 Error Detector, 115
 Pattern Generator, 84
 ISI, 320

J

Jitter
 example, 171
 fast total, 178
 Generation Block Diagram, 322
 Total, 321
 Types of, 317
 Jitter composition overview, 329
 Jitter Mean, 193
 Jitter Setup, 325
 Jitter Tolerance
 Reference, 348
 Jitter Tolerance Characterization,
 338
 BER, 340, 349
 Confidence level, 340
 Frequency, 349
 Relax time, 341
 Search, 350
 Search methods, 341
 Jitter Tolerance Compliance, 352
 BER, 371
 Confidence level, 355
 Frequency, 370
 Margin, 358
 Predefined Standards, 356
 Reference, 368
 Relax time, 355
 Standard Specification, 368
 Target BER, 354
 User-defined Standards, 357
 Jitter Tolerance Tests
 Basics, 315

L

LAN Connectors, 399
 Level Results, 210
 Linear Markers, 168

Loading
 Pattern, 41
 Pattern directly from Pattern
 Editor, 42
 Logic Families, 74
 Logic Levels Setup, 79
 loop bandwidth, 124
 Low Level, 211
 Low Level Std. Dev., 212

M

Manual Pattern Alternation, 104
 Manually Inserting Errors, 99
 Mark Density, 53
 Markers,
 Gaussian, 169
 introduction, 168
 Linear, 168
 Mean Level, 211
 Measured Points, 234
 Measurement Log, 153, 382
 Measurement points
 defaults, 243
 Measurements, 297
 Memory-based Patterns, 23
 Min BER for Q, 209
 More Errored 0's than 1's, 379
 MUX/DEMUX Pair
 Connections, 20

N

N4916A, 12
 Basics, 77
 Connections, 22
 control, 81
 Installation, 407
 Troubleshooting, 386
 No. of points, 193
 Noise Threshold, 295
 Normal, 114
 not applicable, 194
 Number of Compared Bits
 Eye Opening, 229
 Fast Eye Mask, 246
 Output Levels, 203
 Output Timing, 185

Number of Errors
 Eye Opening, 229
 Fast Eye Mask, 246
 Output Levels, 204
 Output Timing, 185
 Number of Top Frequencies to Show,
 295
 Number of Valid Points, 247
 Numerical Results
 Eye Opening, 235
 Output Levels, 210
 Output Timing, 192
 Spectral Jitter, 296

O

Offset threshold, 247
 On-Screen Keyboard, 402
 Optimal Sample Point Delay, 192, 195,
 235
 Optimal Sample Point Threshold, 235
 Optimum Sampling Point, 129
 Oscilloscope Connections, 20
 Output blanking, 85
 Output Level Parameters, 73
 Output Levels measurement, 195
 Output Protection, 72
 Output Timing measurement, 173
 Output Timing Measurement
 Optimization, 185

P

Parameters
 Bounded uncorrelated jitter, 331
 External jitter, 333
 Periodic jitter, 332
 Random jitter, 330
 Sinusoidal jitter, 334
 Parameters Tab
 Eye Opening, 229
 Fast Eye Mask, 246
 Output Levels, 203
 Output Timing, 184
 Spectral Jitter, 289

Pass/Fail tab
 Eye Opening, 230
 Fast Eye Mask, 248
 Output Levels, 205
 Output Timing, 186
 Spectral Jitter, 291

Pattern
 Alternation, 102
 Creating New, 39
 Editing, 40
 Editor, 43, 62
 Examples, 33
 from file, 23
 Generated Patterns, 53
 Hardware generated, 23
 Length, 30
 Load status indicators, 50
 Loading directly from Pattern Editor, 42
 Loading from file, 41
 mark density, 53
 memory-based, 23
 Opening Existing, 39
 PRBN, 25
 PRBS, 23, 24
 Properties, 47
 provided patterns, 24
 Repetition, 31
 Resolution, 30
 Saving, 40
 Selecting, 50
 Sequence, 41
 Sequence of patterns, 56
 Setup, 23
 software-generated, 24, 53
 Supported Types, 28
 Which Is Appropriate?, 26

Pattern Alternation
 Manually, 104
 With External Signal, 105

Pattern Generator
 Auxiliary Input, 71
 Clock In port, 70
 Clock Out port, 71
 Data Out port, 71
 Delay Control Input, 71
 Error Add input, 70
 Input and Output Ports, 70
 Ref. Clock input, 70
 Setup, 69
 Sub Clock Out port, 71
 Trigger Out port, 71

Pattern Mode, 58
 Pattern Synchronization, 138
 Peak Peak Noise, 212
 Percentage threshold, 247
 Periodic jitter (PJ), 318
 PG CLK LOSS, 376
 Phase Margin, 192, 195
 PJ, 318
 Planning the Test, 9
 Post-cursor de-emphasis, 78
 Power scale, 293
 PRBN, 25
 PRBS, 24
 PRBS Patterns, 23
 Pre-cursor de-emphasis, 78
 Printing, 418
 Problems, 375
 Constant Errors (More Errored 0's than 1's), 379
 Random Errors, 380
 Sync Loss Seconds, 381

Properties dialog box
 DUT Output Timing/Jitter, 184
 Eye Opening, 229
 Fast Eye Mask, 246
 Output Levels, 203
 Spectral Jitter, 289

Pseudo Color Plot, 222

Q

Q Factor, 213
 Q High Level, 214
 Q High Level Nr. Points, 214
 Q High Level R², 214
 Q High Level Std.Dev, 214

Q Low Level, 215
 Q Low Level Nr. Points, 215
 Q Low Level R², 215
 Q Low Level Std.Dev, 215
 Q Optimum Threshold, 213
 Q Residual BER, 213
 Q-Factor Calculations
 mathematics, 216
 Notes, 218
 QBER vs. Threshold Graph, 208

R

R² values, 193
 Random Errors, 380
 Random jitter (RJ), 318
 Random Jitter RMS, 193
 Ratios Graph, 305
 Relative Time, 248
 Requirements, 14
 Resolution
 Eye Opening, 229
 Fast Eye Mask, 230
 Output Levels, 204
 Output Timing, 185

Results
 see Numerical Results, 192

Return to Results button, 136
 RJ, 318
 Running Measurements, 297

S

Sampling Point Setup, 126
 Saving Patterns, 40
 Self Test, 426
 Sequence
 creating, 59
 definition, 56
 loops, 63
 properties, 66
 recalling, 60
 saving, 60

Sequence Editor, 61
 Toolbox, 64

Sequence Mode, 58
 SequenceExpression, 56
 Sequences, 56

- Serial BERT
 - introduction, 9
 - Setting Date and Time, 398
 - SI, 321
 - Signal/Noise Ratio (Peak Peak), 212
 - Sinusoidal Interference, 338
 - Sinusoidal Interference (SI), 321
 - Software-generated patterns, 24
 - Software-generated patterns, 53
 - Software-generated patterns;Pattern:software-generated, 51
 - Solving Problems, 375
 - SONET/SDH Receiver
 - Connections, 21
 - Spectral Jitter measurement
 - procedure, 286
 - Spread Spectrum Clocking, SSC, 89
 - Standard patterns, 24
 - Status Indicators, 300
 - Sub Clock Out port, 71
 - Supported Pattern Types, 28
 - SYNC LOSS, 377
 - Sync Loss Seconds, 381
 - Sync Now button, 133
- T**
- Termination
 - Error Detector, 115
 - Terminations
 - Setup, 79
 - Usage, 74
 - Test
 - Duration, 15
 - Planning, 9
 - Requirements, 14
 - Which Test Is Appropriate?, 13
 - Test points (Fast Eye Mask), 242
 - Threshold
 - absolute, 247
 - offset, 247
 - percentage, 247
 - Threshold Eye Opening, 235
 - Threshold Margin, 211
 - Threshold Resolution
 - High Level (Eye Opening measurement), 230
 - High Level (Output Levels measurement), 204
 - Low Level (Output Levels measurement), 204, 230
 - Threshold Types, 247
 - Time Eye Opening, 235
 - Timing Unit
 - Eye Opening measurement, 234
 - Fast Eye Mask measurement, 247
 - Total Jitter BER Threshold, 195
 - Total Jitter Peak-Peak, 195
 - Total Jitter Peak-to-Peak, 193
 - Total Jitter RMS, 193
 - Total Jitter Uncertainty, 195
 - Touchscreen
 - Calibration, 401
 - Off/On, 401
 - Transition Density, 124
 - Trigger
 - Error Detector, 136
 - Trigger Out
 - Error Detector, 112
 - Pattern Generator, 93
 - Trigger Out port, 71
 - Troubleshooting, 375
- U**
- Uncertainty Band, 179
 - User pattern, 23
 - User-Defined Sequences, 56
- V**
- Vampt, 84
 - Variable Mark Density, 53
 - Vhi, 83
- W**
- View Tab
 - Eye Opening, 232
 - Output Levels, 207
 - Output Timing, 188
 - Spectral Jitter, 293
 - View tab
 - Fast Eye Mask, 248
 - Vlo, 83
 - Vof, 83
 - Voltage
 - of measurement point, 248
- X**
- Xover, 84
- Z**
- Zero SubstitutionPattern
 - zero substitution, 52
 - Zoom Function
 - Eye Opening, 234
 - Output Level, 209
 - Output Timing, 191
 - Spectral Jitter, 295

